

**Republic of South Sudan**

**Laws of South Sudan**

**CIVIL AVIATION AUTHORITY  
AERODROME DESIGN AND OPERATIONS  
REGULATIONS, 2026**

**CIVIL AVIATION AUTHORITY AERODROME DESIGN AND OPERATION  
REGULATION, 2026**

## **ARRANGEMENT OF CHAPTERS**

### **CHAPTER I PRELIMINARY PROVISIONS**

1. Title and Commencement
2. Purpose
3. Authority and Application
4. Interpretation

### **CHAPTER II AERODROMES DESIGN AND CONSTRUCTION, (ANNEX 14 CHAPTER1)**

5. Use of Common Reference Systems
6. Categories of Aerodromes
7. Requirements for Application for an Aerodrome Construction Permit
8. Issuance of Aerodrome Construction Permits
9. Design and Construction of Aerodromes
10. Requirement for Aerodrome Design
11. Airport Design and Master Plan
12. Aerodrome Reference Code
13. Specific Procedure for Aerodrome Operations

### **CHAPTER III INFORMATION TO BE REPORTED TO AERONAUTICAL INFORMATION SERVICES (ANNEX 14 CHAPTER 2)**

14. Availability of Information
15. Action Required for Occurrences of Operational Significance Other Than Those Involving Electronic Aids and Communication Facilities
16. Action Required for Occurrences that Affect Electronic Aids and Communication Facilities
17. Aeronautical Data Reporting

### **CHAPTER IV AERODROME DATA (ANNEX 14 CHAPTER 2)**

18. Aerodrome Data and Related Information
19. Aeronautical Data
20. Aerodrome Reference Point
21. Aerodrome And Runway Elevations
22. Aerodrome Reference Temperature
23. Aerodrome Dimensions and Related Information
24. Strength of Pavements
25. Flight Altimeter Check Location
26. Declared Distances
27. Condition of the Movement Area and Related Facilities

28. Runway Surface Condition(S) for Use in The Runway Condition Report
29. Responsibility for Removal of Disabled Aircraft
30. Information on Level of Protection of Rescue and Fire Fighting
31. Visual Approach Slope Indicator Systems
32. Coordination Between Aeronautical Information Services and Aerodrome Authorities

**CHAPTER V**  
**AERODROMES PHYSICAL CHARACTERISTICS**

33. Application
34. Standards for Physical Characteristics of An Aerodrome
35. Runways Number and Orientation of Runways
36. Choice of Maximum Permissible Cross-Wind Components
37. Data To Be Used for The Calculation of The Runway Usability Factor
38. Location of Threshold
39. Determination of Actual Length of Runways
40. Determination of Width of Runway
41. Determination of Minimum Distance Between Parallel Runways
42. Slopes on Runways
43. Strength of Runways
44. Surface of Runways
45. Runway Shoulders
46. Runway Turn Pads
47. Runway Strips
48. Slopes on Runway Strips
49. Runway End Safety Area
50. Clearway
51. Stop Ways
52. Radio Altimeter Operating Area
53. Taxiways
54. Rapid Exit Taxiways
55. Taxiways on Bridges
57. Taxiway Strips
58. Holding Bays, Runway Holding Positions, Intermediate Holding Positions and Road Holding Positions
59. Aprons
60. Isolated Aircraft Parking Position

**CHAPTER VI**  
**OBSTACLE RESTRICTION AND REMOVAL**

61. Establishment of Obstacle Limitation Surfaces
62. Obstacle Limitation Surfaces
63. Outer Horizontal Surface
64. Conical Surface
65. Inner Horizontal Surface
66. Approach Surface

- 67. Inner Approach Surface
- 68. Transitional Surface
- 69. Inner Transitional Surface
- 70. Balked Landing Surface
- 71. Take-Off Climb Surface
- 72. Obstacle Limitation Requirements for Non- Instrument Runways
- 73. Obstacle Limitation Requirements for Non-Precision Approach Runway
- 74. Obstacle Limitation Requirements for Precision Approach Runways
- 75. Obstacle Limitation Requirements for Runways Meant for Take-Of
- 76. Objects Outside Obstacle Limitation Surfaces
- 77. Other Objects

**CHAPTER VII  
VISUAL AIDS FOR NAVIGATION**

- 78. Wind Direction Indicators
- 79. Landing Direction Indicator
- 80. Signalling Lamp
- 81. Signal Panel and Signalling Area
- 82. General Requirements for Markings
- 83. Interruption of Runway Markings
- 84. Runway Designation Marking
- 85. Runway Centreline Marking
- 86. Threshold Marking
- 87. Aiming Point Marking
- 88. Touchdown Zone Marking
- 89. Runway Side Stripe Marking
- 90. Taxiway Centreline Markings
- 91. Runway Turn Pad Marking
- 92. Runway-Holding Position Marking
- 93. Intermediate Holding Position Marking
- 94. VOR Aerodrome Checkpoint Marking
- 95. Aircraft Stand Markings
- 96. Apron Safety Lines.
- 97. Road-Holding Positions.
- 98. Mandatory Instruction Markings
- 99. Information Marking
- 100. Laser Emissions Which May Endanger the Safety of Aircraft
- 101. Elevated Approach Lights
- 102. Elevated Lights
- 103. Surface Lights
- 104. Light Intensity and Control
- 105. Emergency Lighting
- 106. Provision of Aeronautical Beacons
- 107. Aerodrome Beacon
- 108. Identification Beacon

109. Approach Lighting System
110. Simple Approach Lighting System
111. Precision Approach Category I Lighting System
112. Precision Approach Category II and III Lighting System
113. Visual Approach Slope Indicator Systems
114. Approach Slope and Elevation Setting of Light Beams
115. PAPI and APAPI
116. Approach Slope and Elevation Setting of Light Units
117. Obstacle Protection Surface for PAPI and APAPI
118. Circling Guidance Lights
119. Runway Lead-In Lighting Systems
120. Runway Threshold Identification Lights
121. Runway Edge Lights
122. Runway Threshold and Wing Bar Lights
123. Runway End Lights
124. Runway Centre Line Lights
125. Runway Touchdown Zone Lights
126. Simple Touchdown Zone Lights
127. Rapid Exit Taxiway Indicator Lights
128. Stop-Way Lights
129. Taxiway Centre Line Lights
130. Taxiway Centre Line Lights on A Straight Section of a Taxiway
131. Taxiway Centre Line Lights on Rapid Exit Taxiways
132. Taxiway Centre Line Lights on Other Exit Taxiways
133. Taxiway Centre Line Lights on Runways
134. Taxiway Edge Lights
135. Runway Turn Pad Lights
136. Stop Bars
137. Intermediate Holding Position Lights
138. Runway Guard Lights
139. Apron Floodlighting
140. Visual Docking Guidance System
141. Azimuth Guidance Unit
142. Stopping Position Indicator
143. Advanced Visual Docking Guidance System
144. Aircraft Stand Manoeuvring Guidance Lights
145. Road-Holding Position Light
146. No-Entry Bar
147. Runway Status Lights
148. Provision of Signs
149. Mandatory Instruction Signs
150. Information Sign
151. VOR Aerodrome Checkpoint Sign
152. Aerodrome Identification Sign

- 153. Aircraft Stand Identification Signs
- 154. Road-Holding Position Sign
- 155. Provision of Markers
- 156. Paved Runways Edge Markers
- 157. Stop Way Edge Markers
- 158. Taxiway Edge Markers
- 159. Taxiway Centre Line Markers
- 160. Unpaved Taxiway Edge Markers
- 161. Boundary Markers

**CHAPTER VIII  
VISUAL AIDS FOR DENOTING OBSTACLES**

- 162. Provision of Visual Aids for Denoting Obstacles
- 163. Objects Within the Lateral Boundaries of the Obstacle Limitation Surfaces
- 164. Objects Outside the Lateral Boundaries of the Obstacle Limitation Surfaces
- 165. Marking and/ or Lighting of Objects
- 166. Marking and Lighting of Mobile Objects
- 167. Marking of Fixed Objects
- 168. Marking By Flag
- 169. Lighting of Fixed Objects
- 170. Lighting of Objects with Height Less Than 45 M Above Ground Level
- 171. Lighting of Objects with A Height 45m Or More to A Height Less Than 150 M Above Ground Level
- 172. Lighting of Objects with A Height 150 M or More Above Ground Level
- 173. Marking of Wind Turbines
- 174. Lighting of Wind Turbines
- 175. Marking of Overhead Wires and/or, Cables, And Supporting Towers
- 176. Lighting of Overhead Wires and/or, Cables, And Supporting Towers

**CHAPTER IX  
VISUAL AIDS FOR DENOTING RESTRICTED USE AREAS**

- 177. Marking of Restricted Use Areas
- 178. Marking and Lighting of Closed Runways and Taxiways, or Parts Thereof
- 179. Marking of Non-Load-Bearing Surfaces
- 180. Marking of Pre-Threshold Areas
- 181. Marking and Lighting of Unserviceable Areas

**CHAPTER X  
ELECTRICAL SYSTEMS**

- 182. Electrical Power Supply Systems for Air Navigation Services and Facilities
- 183. Electrical

## **System Design**

- 184. Monitoring of Electrical Systems

## **CHAPTER XI AERODROME OPERATIONAL SERVICES, EQUIPMENT, INSTALLATIONS AND FACILITIES**

- 185. Application
- 186. General Aerodrome Emergency Planning Requirements
- 187. Emergency Planning Committee
- 188. Emergency Operation Centre and Command Post
- 189. Communication System
- 190. Aerodrome Emergency Exercise
- 191. Emergencies In Difficult Environment
- 192. Provision of Aerodrome Rescue and Firefighting Services
- 193. Level of Protection for Rescue and Firefighting Services to Be Provided
- 194. Extinguishing Agents
- 195. Rescue Equipment
- 196. Response Time for Rescue and Firefighting Services
- 197. Establishment of Emergency Access Roads
- 198. Fire Stations
- 199. Communication and Alerting Systems for Rescue and Firefighting Services
- 200. Number of Rescue and Fire Fighting Vehicles
- 201. Requirements for Rescue and Firefighting Personnel
- 202. Maintenance of Fire Prevention Programme
- 203. Removal of Disabled Aircraft

### **Wildlife Strike Hazard Reduction**

- 204. Wildlife Hazard Management
- 205. Wildlife Strike Hazard Reduction at Aerodrome
- 206. National Committee on Wildlife Hazard Management
- 207. Responsibilities of the National Committee on Wildlife Hazard Management
- 208. Composition of the National Committee on Wildlife Hazard Management  
Apron Management Service
- 209. Provision of Apron Management Service
- 210. Ground Servicing of Aircraft
- 211. Aerodrome Vehicle Operation
- 212. Surface Movement Guidance and Control Systems
- 213. Siting of Equipment and Installations on Operational Areas
- 214. Fencing of Aerodromes and Installations
- 215. Security Lighting of Aerodrome Fence
- 216. Autonomous Runway Incursion Warning System (ARIWS)
- 217. Maintenance of Safety Inspection Programme
- 218. Access of Ground Vehicles to Aerodrome Movement Area
- 219. Supply of Aviation Fuel to Aircraft

**CHAPTER XII  
AERODROME MAINTENANCE**

- 220. Maintenance Programme
- 221. Maintenance of Pavements and Adjacent Areas
- 222. Removal of Contaminants
- 223. Maintenance of Runway Pavement Overlays
- 224. Preventive Maintenance of Visual Aids
- 225. Construction or Maintenance Activity During Low Visibility Operations
- 226. Works At Aerodromes

**CHAPTER XIII  
GENERAL PROVISIONS**

- 227. Application for Exemption Aeronautical Study
- 228. Deviations From These Regulations
- 229. Safety Inspections and Audits
- 230. Enforcement
- 231. Contravention of Regulations

**CHAPTER XIV  
MISCELLANEOUS PROVISIONS**

- 232. Savings and Transition
- 233. Revocation
- 234. Offences and Penalties

**SCHEDULES**

<b>FIRST SCHEDULE</b>	Systematic Management of Safety at Aerodrome.
<b>SECOND SCHEDULE</b>	Shielding of Obstacles.
<b>THIRD SCHEDULE</b>	Colours of Aeronautical Ground Lights, Markings, Signs and Panels.
<b>FOURTH SCHEDULE</b>	Aeronautical Ground Light Characteristics.
<b>FIFTH SCHEDULE</b>	Mandatory Instruction Markings and Information Signs.
<b>SIXTH SCHEDULE</b>	Requirements Concerning Design of Taxiway Guidance Signs.
<b>SEVENTH SCHEDULE</b>	Location of Lights on Obstacles
<b>EIGHT SCHEDULE</b>	Guidance Material Supplementary to The Regulations
<b>NINTH SCHEDULE</b>	Obstacle Limitation Surface

**CIVIL AVIATION AUTHORITY AERODROME DESIGN AND OPERATION  
REGULATION, 2026**

**In exercise of power conferred upon me under the provision of Section 99 of the South Sudan Civil Aviation Act, 2012 (Amendment, 2024), I hereby issue the following Regulations:**

**CHAPER I  
PRELIMINARY PROVISIONS**

**1. Title and Commencement**

This Regulation may be cited as the “Certification, Licensing and Registration of Aerodromes Regulations, 2026” and shall come into force on the date of its signature by the Minister.

**2. Purpose**

The purpose of this regulation is to provide the legal frame work that govern and regulate the operation of the Heliports in the Republic of South Sudan.

**3. Authority and Application**

(1) This regulation is drafted in accordance with the provision of section 99 of the Civil Aviation Authority Act,2012 (Amendment 2024).

(2) This regulation shall apply to

- (a) to all civil aerodromes in South Sudan except where otherwise specified;
- (b) Save as provided, an aerodrome operator shall generally comply with specifications as set out in these regulations;
- (c) The specifications of these Regulations, shall apply only to land aerodromes;
- (d) The specifications in this volume shall apply, where appropriate, to heliports but shall not apply to STOL port; and
- (e) Wherever a colour is referred to in this Regulation, the specifications for that color given in the Third Schedule shall apply.

**4. Interpretation**

In these Regulations unless the context otherwise requires:

**“Accident”**

means an occurrence associated with the operation of an aircraft which, in the case of a manned aircraft, takes place between the time any person boards the aircraft with the intention of flight until such time as all such persons have disembarked, or in the case of an unmanned aircraft, takes place between the time the aircraft is ready to move with the purpose of flight until such time as it comes to rest at the end of the flight and the primary propulsion system is shut down, in which:

- (1) a person is fatally or seriously injured as a result of:
  - (a) being in the aircraft;

- (b) direct contact with any part of the aircraft, including parts which have become detached from the aircraft; and
  - (c) direct exposure to jet blast except when the injuries are from natural causes, self-inflicted or inflicted by other persons, or when the injuries are to stowaways hiding outside the areas normally available to the passengers and crew.
- (2) the aircraft sustains damage or structural failure which:
- (a) adversely affects the structural strength, performance or flight characteristics of the aircraft;
  - (b) normally require major repair or replacement of the affected component; except for engine failure or damage, when the damage is limited to a single engine (including its cowlings or accessories), to propellers, wing tips, antennas, probes, vanes, tires, brakes, wheels, fairings, panels, landing gear doors, windcreens, the aircraft skin (such as small dents or puncture holes, or for minor damages to main rotor blades, tail rotor blades, landing gear, and those resulting from hail or bird strike (including holes in the radome; and
  - (c) the aircraft is missing or is completely inaccessible. For statistical uniformity only, an injury resulting in death within thirty days of the date of the accident is classified as a fatal injury. An aircraft is considered to be missing when the official search has been terminated and the wreckage has not been located

- “Accuracy”** means a degree of conformance between the estimated or measured value and the true value;
- “Aerodrome”** means a defined area on land or water (including any buildings, installations and equipment) intended to be used either wholly or in part for the arrival, departure and surface movement of aircraft;
- “Aerodrome Beacon”** means an aeronautical beacon used to indicate the location of an aerodrome from the air;
- “Aerodrome Certificate”** means a certificate issued by the Authority under Part IV of these regulations for the operation of an aerodrome;
- “Aerodrome Elevation”** means the elevation of the highest point of the landing area;
- “Aerodrome Facilities and Equipment”** means facilities and equipment, inside or outside the boundaries of an aerodrome that are constructed or installed

and maintained for the arrival, departure and surface movement of aircraft;

**“Aerodrome Identification Sign”** means a sign placed on an aerodrome to aid in identifying the aerodrome from the air;

**“Aerodrome Licence”** means a licence to operate an aerodrome issued by the Authority under the Civil Aviation (Certification, Licensing and Registration of Aerodromes) Regulations for the operation of an aerodrome;

**“Aerodrome Manual”** means the manual that forms part of the application for a licence or a certificate under the Civil Aviation Certification, Licensing and Registration of Aerodromes, including any amendments to the manual, approved by the Authority;

**“Aerodrome Mapping Data - AMD”** means data collected for the purpose of compiling aerodrome mapping information for aeronautical uses;

**“Aerodrome Mapping Database - AMDB”** means a collection of aerodrome mapping data organized and arranged as a structured data;

**“Aerodrome Operator”** in relation to a certified or licensed aerodrome, means, the holder of an Aerodrome certificate or licence;

**“Aerodrome Reference Code”** means a code used for planning purposes to classify an aerodrome with respect to the critical aircraft characteristics for which the aerodrome is intended;

**“Aerodrome Reference Point”** means the designated geographical location of an aerodrome;

**“Aerodrome Traffic Density”** means:

- (a) **Light:** Where the number of movements in the mean busy hour is not greater than 15 per runway or typically less than 20 total aerodrome movements;
- (b) **Medium:** Where the number of movements in the mean busy hour is of the order of 16 to 25 per runway or typically between 20 to 35 total aerodrome movements;
- (c) **Heavy:** Where the number of movements in the mean busy hour is of the order of 26 or more per runway or typically more than 35 total aerodrome movements

**“Aerodrome Traffic Zone”** means the airspace extending from aerodrome level to a height of two thousand feet over the area comprising the aerodrome and the surrounding land or water within a distance of two thousand yards of its boundaries;

**“Aeronautical Beacon”** means an aeronautical ground light visible at all azimuths, either continuously or intermittently, to designate a particular point on the surface of the earth;

- “Aeronautical Ground Light”** means any light provided as an aid to air navigation, other than a light displayed on an aircraft;
- “Aeronautical Information Circular – AIC”** means a notice containing information that does not qualify for the origination of a NOTAM or for inclusion in the Aeronautical Information Publication, but which relates to flight safety, air navigation, technical, administrative or legislative matters;
- “Aeronautical Information Publication – AIP”** means an aeronautical information publication of a lasting character essential to air navigation, issued by the Authority;
- “Aeroplane Reference Field Length”** means the minimum field length required for take-off at maximum certificated take-off mass, sea-level, standard atmospheric conditions, still air and zero runway slope, as shown in the appropriate aeroplane flight manual prescribed by the certifying authority or equivalent data from the aeroplane manufacturer. Field length means balanced field length for aeroplane, where applicable, or take-off distance in other cases;
- “Air Traffic Service – ATS”** means a flight information service, alerting service, air traffic Advisory service, or air traffic control service;
- “Air Traffic Service Unit”** is a generic term meaning variously, air traffic control unit, flight information centre or air traffic services reporting office;
- “Aircraft Classification Number ACN”** means a number expressing the relative effect of an Aircraft on a pavement for a specified standard sub grade category;
- “Aircraft Classification Rating ACR”** means a number expressing the relative effect of an aircraft on a pavement for a specified standard subgrade category.
- “Aircraft Stand”** means a designated area on an apron intended to be used for parking an aircraft;
- “ADP”** means airside driver permit;
- “Apron”** means a defined area, on an aerodrome, intended to accommodate aircraft for purposes of loading or unloading of passengers, mail or cargo, fuelling, parking or maintenance;
- “Apron Management Service”** means a service provided to regulate the activities and the movement of aircraft and vehicles on an apron;
- “Arresting System”** means a system designed to decelerate an aeroplane overrunning the runway;
- “Autonomous Runway Incursion Warning System - ARIWS”** means a system which provides autonomous detection of a potential incursion or of the occupancy of an active runway and a direct warning to a flight crew or a vehicle operator.

<b>“Authority”</b>	means the South Sudan Civil Aviation Authority;
<b>“Authorized Person”</b>	means any person authorized by the Authority either generally or in relation to a particular case or class of cases and reference to an authorized person includes references to the holder for the time being of an office designated by the Authority;
<b>“Balked Landing”</b>	means a landing manoeuvre that is unexpectedly discontinued at any point below the obstacle clearance altitude/height (OCA/H);
<b>“Barrette”</b>	means three or more aeronautical ground lights closely spaced in a transverse line so that from a distance they appear as a short bar of light;
<b>“Minister”</b>	means the Minister responsible for Transport;
<b>“Calendar”</b>	means discrete temporal reference system that provides the basis for defining temporal position to a resolution of one day;
<b>“Certificate”</b>	means the certificate to operate an aerodrome issued by the Authority under the Civil Aviation Certification, Licensing and Registration of Aerodromes;
<b>“Certified Aerodrome”</b>	means an aerodrome whose operator has been granted an Aerodrome Certificate;
<b>“Clearway”</b>	means a defined rectangular area under the control of the appropriate authority selected or prepared as a suitable area over which an aircraft may make a portion of its initial climb to a specified height;
<b>“Controlled Aerodrome”</b>	means an aerodrome where air traffic services are provided;
<b>“Critical Aircraft”</b>	means the most demanding aircraft with regard to the aircraft performance and dimensions for a range of aircraft, for which the aerodrome facilities are intended;
<b>“Cross Wind Component”</b>	means the surface wind component at right angles to the runway centre line;
<b>“Cyclic Redundancy Check CRC”</b>	means a mathematical algorithm applied to the digital expression of data that provides a level of assurance against loss or alteration of data;
<b>“Dangerous Goods”</b>	means articles or substances which are capable of posing a risk to health, safety, property or the environment.
<b>“Data Accuracy”</b>	means a degree of conformance between the estimated or measured value and the true value.
<b>“Data Quality”</b>	means a degree or level of confidence that the data provided meet the requirements of the data user in terms of accuracy, resolution and integrity;

- “Data Integrity (Assurance Level)”** means a degree of assurance that an aeronautical data and its value has not been lost or altered since the origination or authorized amendment;
- “Datum”** means any quantity or set of quantities that may serve as a reference or basis for the calculation of other quantities;
- “Declared Distance”** means:
- (a) **“Accelerate-Stop Distance Available ASDA”** which is the length of the take-Off run available plus the length of the stop way, where provided;
  - (b) **“Landing Distance Available LDA”** which is the length of the runway which is declared available and suitable for the ground run of an aircraft landing;
  - (c) **“Take-Off Distance Available TODA”** which is the length of the take-off run available plus the length of the clearway, where provided;
  - (d) **“Take-Off Run Available TORA”** which is the length of runway declared available and suitable for the ground run of an aircraft taking off;
- “Dependent Parallel Approaches”** means simultaneous approaches to parallel or near-parallel instrument runways where radar separation minima between aircraft on adjacent extended runway centre lines are prescribed;
- “Displaced Threshold”** means a threshold not located at the extremity of a runway;
- “Effective Intensity”** means the effective intensity of a flashing light is equal to the intensity of a fixed light of the same colour which shall produce the same visual range under identical conditions of observations;
- “Ellipsoid Height Geodetic Height”** means the height related to the reference ellipsoid, measured along the ellipsoidal outer normal through the point in question;
- “Fixed Light”** means a light having constant luminous intensity when observed from a fixed point;
- “Foreign Object Debris FOD”** means an inanimate object within the movement area which has no operational or aeronautical function and which has the potential to be a hazard to aircraft operations;
- “Frangible Object”** means an object of low mass designed to break, distort or yield on impact so as to present the minimum hazard to aircraft.
- “Geodetic Datum”** means a minimum set of parameters required to define location and orientation of the local reference system with respect to the global reference system frame.

<b>“Geoid”</b>	means the equipotential surface in the gravity field of the earth which coincides with the undisturbed Mean Sea Level extended continuously through the continents;
<b>“Geoid Undulation”</b>	the distance of the geoid above (positive) or below (negative) the mathematical reference ellipsoid;
<b>“Gregorian Calendar”</b>	means calendar in general use; first introduced in 1582 to define a year that more closely approximates the tropical year than the Julian calendar in the Gregorian calendar, common years have 365 days and leap years 366 days divided into twelve sequential months;
<b>“Hazard Beacon”</b>	means an aeronautical beacon used to designate a danger to air navigation;
<b>“Helicopter”</b>	means an aircraft that is borne along by one or more sets long rotating blades which allow it to hover
<b>“Heliport”</b>	means an aerodrome or a defined area on a structure intended to be used wholly or in part for the arrival, departure and surface movement of helicopters;
<b>“Holding Bay”</b>	means a defined area where aircraft can be held, or bypassed, to facilitate efficient surface movement of aircraft;
<b>“Holdover Time”</b>	means the estimated time the anti-icing fluid (treatment) will prevent the formation of ice and frost and the accumulation of snow on the protected (treated) surfaces of an aeroplane;
<b>“Hot Spot”</b>	means a location on an aerodrome movement area with a history or potential risk of collision or runway incursion, and where heightened attention by pilots/drivers is necessary.
<b>“Human Factor Principles”</b>	means principles which apply to aeronautical design, certification, training, operations and maintenance and which seek safe interface between the human and other system components by proper consideration to human performance;
<b>“Human Performance”</b>	means human capabilities and limitations, which have an impact on the safety and efficiency of aeronautical operations;
<b>“Identification Beacon”</b>	means an aeronautical beacon emitting a coded signal by means of which a particular point of reference can be identified;
<b>“Incident”</b>	means an occurrence other than an accident associated with the operation of an aircraft, which affect or may affect the safety of operation of aircraft;
<b>“Independent Parallel Approaches”</b>	means simultaneous approaches to parallel or near-parallel instrument runways where radar separation minima between aircraft on adjacent extended runway centre lines are not prescribed;

**“Independent Parallel Departures”** means simultaneous departures from parallel or near-parallel instrument runways;

**“Instrument Runway”** means one of the following types of runways intended for the operation of aircraft using instrument approach procedures:

- (a) **Non- Precision Approach Runway”** means a runway served by visual aids and non-visual aids **Intended** for landing operations following an instrument approach operation type A and a visibility not less than 1000 m;
- (b) **Precision Approach Runway, Category I”** means a runway served by visual aids and non-visual aid(s) intended for landing operations following an instrument approach operation type B with a decision height (DH) not lower than 60 m (200 ft) and either a visibility not less than 800 m or a runway visual range not less than 550 m;
- (c) **Precision Approach Runway, Category II”** means a runway served by visual aids and non-visual aid(s) intended for landing operations following an instrument approach operation type B with a decision height (DH) lower than 60 m (200 ft) but not lower than 30 m (100 ft) and a runway visual range not less than 300 m;
- (d) **Precision Approach Runway Category III”** means a runway served by visual aids and non-visual aid(s) intended for landing operations following an instrument approach operation type B with a decision height (DH) lower than 30 m (100 ft), or no decision height and a runway visual range not less than 300 m or no runway visual range limitations; (Visual aids need not necessarily be matched to the scale of non-visual aids provided. The criterion for the selection of visual aids is the conditions in which operations are intended to be conducted. Refer to the Civil Aviation Operation of aircraft regulations for instrument approach operation types);

**“Integrity Aeronautical Data”** means a degree of assurance that an aeronautical data and its value has not been lost nor altered since the data origination or authorized amendment;

**“Integrity Classification, Aeronautical Data”** means classification based upon the potential risk resulting from the use of corrupted data. Aeronautical data is classified as:

- (a) **Routine Data:** there is a very low probability when using corrupted routine data that the continued safe flight and landing of an aircraft will be severely at risk with the potential for catastrophe;

- (b) **Essential Data:** there is a low probability when using corrupted essential data that the continued safe flight and landing of an aircraft will be severely at risk with the potential for catastrophe; and
- (c) **Critical Data:** there is a high probability when using corrupted critical data that the continued safe flight and landing of an aircraft will be severely at risk with the potential for catastrophe.

**“Intermediate Holding Position”** means a designated position intended for traffic control at which taxiing aircraft and vehicles stop and hold until they are cleared to proceed, when so instructed by the aerodrome control tower;

**“Landing Area”** means that part of a movement area intended for the landing or take-off of aircraft;

**“Landing Direction Indicator”** means a device to indicate visually the direction currently designated for landing and take-off;

**“Laser-Beam Critical Flight Zone LCFZ”** means an airspace in the proximity of an aerodrome but beyond the LFFZ where the irradiance is restricted to a level unlikely to cause glare effects.

**“Laser-Beam Free Flight Zone LFFZ”** means an airspace in the immediate proximity of the aerodrome where the irradiance is restricted to a level unlikely to cause any visual disruption.

**“Laser-Beam Sensitive Flight Zone (LSFZ)”** means an airspace outside, and not necessarily contiguous with, the LFFZ and LCFZ where the irradiance is restricted to a level unlikely to cause flash-blindness or after-image effects.

**“Licence”** means a licence to operate an aerodrome issued by the Authority under the Civil Aviation Certification, Licensing and Registration of Aerodromes

**“Lighting System Reliability”** means the probability that the complete installation operates within the specified tolerances and that the system is operationally usable;

**“Manoeuvring Area”** means that part of an aerodrome to be used for the take-off, landing and taxiing of aircraft, excluding aprons;

**“Marker”** means an object displayed above ground level in order to indicate an obstacle or delineate a boundary;

**“Marking”** means a symbol or group of symbols displayed on the surface of the movement area in order to convey aeronautical information;

**“Movement Area”** means that part of the aerodrome to be used for take-off, landing and taxiing of aircraft, consisting of the manoeuvring area and apron;

- “Near-Parallel Runways”** means non-intersecting runways whose extended centre lines have an angle of convergence, divergence of 15 degrees or less.
- “Notify”** means shown in Aeronautical Information Publications, Aeronautical Information Circulars, NOTAM, civil aviation publications or any other official publication issued for the purpose of enabling any of the provisions of these Regulations to be complied with;
- “Non-Instrument Runway”** means a runway intended for the operation of aircraft using visual approach procedures;
- “Normal Flight Zone NFZ”** means airspace not defined as LFFZ, LCFZ or LSFZ but which must be protected from laser radiation capable of causing biological damage to the eye;
- “Obstacle”** means any fixed (whether temporary or permanent) and mobile object, or part thereof, that:
- (a) is located on an area intended for the surface movement of aircraft;
  - (b) extends above a defined surface intended to protect aircraft in flight; or
  - (c) stands outside those defined surfaces and that has been assessed as being a hazard to air navigation.
- “Obstacle Free Zone (OFZ)”** means the airspace above the inner approach surface, inner transitional surfaces, the balked landing surface and that portion of the strip bounded by these surfaces, which is not penetrated by any fixed obstacle other than a low-mass and frangible mounted one required for air navigation purposes;
- “Obstacle Limitation Surfaces”** means a series of surfaces that define the volume of airspace at and around an aerodrome to be kept free of obstacles in order to permit the intended aircraft operations to be conducted safely and to prevent the aerodrome from becoming unusable by the growth of obstacles around the aerodrome;
- “Orthometric Height”** means height of a point related to the geoid, generally presented as an MSL elevation.
- “Outer Main Gear Wheel Span OMGWS”** means the distance between the outside edges of the main gear wheels;
- “Operator”** means a person operating an aerodrome licensed, certificated or registered under the Civil Aviation Certification, Licensing and Registration of Aerodromes;
- “Pavement Classification Number PCN”** means a number expressing the bearing strength of a pavement; Applicable until 27 November 2025;
- “Pavement Classification Rating PCR”** means a number expressing the bearing strength of a pavement. Applicable as of 28 November 2025;

- “Precision Approach Runway”** means type of runway at an airport that equipped with precision instrument approach and landing aids;
- “Primary Runway(s)”** means runway(s) used in preference to others whenever conditions permit;
- “Protected Flight Zones”** means an airspace specifically designated to mitigate the hazardous effects of laser radiation;
- “Recommended Practice”** means any specification for the physical characteristic’s configuration, material, performance or procedure, the uniform application of which is recognised as desirable in the interest of safety, regularity or efficiency of international air navigation;
- “Registration Approval”** means an approval to operate an aerodrome granted by the Authority under the Civil Aviation Certification, Licensing and Registration of Aerodromes;
- “Relevant Authority”** means any authority other than the Civil Aviation Authority whose action may be necessary or complimentary for the implementation of these Regulations;
- “Road”** means an established surface route on the movement area meant for the exclusive use of vehicles;
- “Road Holding Position”** means a designated position at which vehicles may be required to hold;
- “Runway”** means a defined rectangular area on a land aerodrome prepared for the landing and take-off of aircraft;
- “Runway Condition Assessment Matrix RCAM”** means a matrix allowing the assessment of the runway condition code, using associated procedures, from a set of observed runway surface condition(s) and pilot report of braking action.;
- “Runway Condition Code RWYCC”** means a number describing the runway surface condition to be used in the runway condition report;
- Note. — The purpose of the runway condition code is to permit an operational aeroplane performance calculation by the flight crew. Procedures for the determination of the runway condition code are described in the PANS-Aerodromes (Doc 9981).
- “Runway Condition Report RCR”** means a comprehensive standardized report relating to runway surface conditions and its effect on the aeroplane landing and take-off performance.
- “Runway Surface Condition(s)”** means a description of the condition(s) of the runway surface used in the runway condition report, which establishes the basis for the determination of the runway condition code for aeroplane performance purposes.

Note 1. The runway surface conditions used in the runway condition report establish the performance requirements between the aerodrome operator, aeroplane manufacturer and aeroplane operator.

Note 2. Aircraft de-icing chemicals and other contaminants are also reported but are not included in the list of runway surface condition descriptors because their effect on runway surface friction characteristics and the runway condition code cannot be evaluated in a standardized manner. 4

Note 3. Procedures on determining runway surface conditions are available in the PANS- Aerodromes Doc 9981.

(a) **Dry Runway.** A runway is considered dry where its surface is free of visible moisture and not contaminated within the area intended to be used.

(b) **Wet Runway.** The runway surface is covered by any visible dampness or water up to and including 3 mm deep within the intended area of use.

(c) **Slippery Wet Runway.** A wet runway where the surface friction characteristics of a significant portion of the runway has been determined to be degraded.

(d) **Contaminated Runway.** A runway is contaminated when a significant portion of the runway surface area (whether in isolated areas or not) within the length and width being used is covered by one or more of the substances listed in the runway surface condition descriptors.

Note. Procedures on determination of contaminant coverage on runway is available in the PANS-Aerodromes (Doc 9981). Runway surface condition descriptors. One of the following elements on the surface of the runway:

Note. The descriptions for e) i) to e) viii), below, are used solely in the context of the runway condition report and are not intended to supersede or replace any existing WMO definitions. Standing water. Water of depth greater than 3 mm.

Note. Running water of depth greater than 3 mm is reported as standing water by convention.

**“Runway End Safety Area RESA”** means an area symmetrical about the extended runway centreline and adjacent to the end of the strip primarily intended to reduce the risk of damage to an aircraft undershooting or overrunning the runway;

- “Runway Guard Lights”** means a light system intended to caution pilots or vehicle drivers that they are about to enter an active runway;
- “Runway-Holding Position”** means a designated position intended to protect a runway, an obstacle limitation surface, or an Instrument Landing System/Microwave Landing System critical or sensitive area at which taxiing aircraft and vehicles shall stop and hold, unless otherwise authorized by the aerodrome control tower;
- “Runway Strip”** means a defined area including the runway and stop way, where provided, intended to:
- (a) reduce the risk of damage to aircraft running off a runway; and
  - (b) protect aircraft flying over it during take-off or landing operations;
- “Runway Turn Pad”** means a defined area on a land aerodrome adjacent to a runway for the purpose of completing a 180-degree turn on a runway;
- “Runway Visual Range RVR”** means the range over which a pilot of an aircraft on the centre line of a runway can see the runway surface markings or the lights delineating the runway or identifying its centre line;
- “Safety”** means a state in which the risk of harm to persons or of property damage is reduced to, and maintained at or below unacceptable level through a continuing process of hazard identification and risk management;
- “Safety Management System SMS”** means a systematic approach to managing safety including the necessary organizational structure, accountabilities, policies and procedures;
- “Segregated Parallel Operations”** means simultaneous operations on parallel or near-parallel instrument runways in which one runway is used exclusively for approaches and the other runway is used exclusively for departures;
- “Shoulder”** means an area adjacent to the edge of a pavement, prepared to provide a transition between the pavement and the adjacent surface;
- “Sign”** means
- (a) **Fixed Message Sign.** A sign presenting only one message.
  - (b) **Variable Message Sign.** A sign capable of presenting several predetermined messages or no message, as applicable;
- “Signal Area”** means an area on an aerodrome used for the display of ground signals;

<b>“Standard”</b>	means any specification for physical characteristics, configuration, material, performance, personnel or procedure, the uniform application of which is recognised as necessary for the safety of air navigation;
<b>“State Safety Programme”</b>	means an integrated set of regulations and activities aimed at improving safety;
<b>“Station Declination”</b>	means an alignment variation between the zero-degree radial of a VOR and true north, determined at the time the VOR station is calibrated;
<b>“Stop Way”</b>	means a defined rectangular area on the ground at the end of the take-off run available, prepared as a suitable area in which an aircraft can be stopped in the case of an abandoned take-off;
<b>“Switch-Over Time (Light)”</b>	means the time required for the actual intensity of a light measured in a given direction to fall from 50 per cent and recover to 50 per cent during a power supply change-over, when the light is being operated at intensities of 25 per cent or above;
<b>“Take-Off Runway”</b>	means a runway intended for take-off only;
<b>“Taxiway”</b>	means a defined path on a land aerodrome established for the taxiing of aircraft and intended to provide a link between one part of the aerodrome and another, including: <ul style="list-style-type: none"> <li>(a) aircraft stand taxi lane which is a portion of an apron designated as a taxiway and intended to provide access to aircraft stands only;</li> <li>(b) apron taxiway which is a portion of a taxiway system located on an apron and intended to provide a through taxi route across the apron;</li> <li>(c) rapid exit taxiway which is a taxiway connected to a runway at an acute angle and designed to allow landing aircrafts to turn off at higher speeds than are achieved on other exit taxiways thereby minimizing runway occupancy times;</li> </ul>
<b>“Taxiway Intersection”</b>	means a junction of two or more taxiways;
<b>“Taxiway Strip”</b>	means an area including a taxiway intended to protect aircraft operating on a taxiway and to reduce the risk of damage to an aircraft accidentally running off the taxiway;
<b>“Threshold”</b>	means the beginning of that portion of the runway usable for landing;
<b>“Touchdown Zone”</b>	means the portion of a runway beyond the threshold, intended for landing aircraft on first contact with the runway;

<b>“Unserviceable Area”</b>	means a part of the movement area that is unfit and unavailable for use by aircraft;
<b>“Usability Factor”</b>	means the percentage of time during which the use of a runway or system of runways is not restricted because of the cross-wind component (cross wind component means the surface wind component at right angles to the runway centre line);
<b>“Vicinity”</b>	means a defined airspace around an aerodrome for control of obstacles that may infringe the obstacle limitation surfaces around the aerodrome, contained within a radius of thirteen kilometres from the aerodrome reference point up to a height of one thousand five hundred feet above ground level;
<b>“Visual Traffic Pattern”</b>	means the aerodrome traffic zone of the aerodrome;
<b>“WIP”</b>	means Work in Progress;
<b>“Wildlife”</b>	means feral birds and animals, including domestic animals out of the control of their owners;
<b>“Wildlife Hazard”</b>	means a potential for a damaging aircraft collision with wildlife on or near an aerodrome; and
<b>“WHMP”</b>	means Wildlife Hazard Management Programme.

## **CHAPTER II**

### **AERODROMES DESIGN AND CONSTRUCTION, (ANNEX 14 CHAPTER1)**

#### **5. Use of Common Reference Systems**

- (1) For the of these regulations:
  - (a) The World Geodetic System – 1984 WGS-84 shall be used as the horizontal geodetic reference system.
  - (b) Reported aeronautical geographical coordinates indicating latitude and longitude shall be expressed in terms of the WGS-84 geodetic reference datum and
  - (c) The Mean Sea Level datum, which gives the relationship of gravity-related height elevation to a surface known as the geoid, shall be used as the vertical reference system elevation at aerodromes.
- (2) Except where notified in the State Aeronautical Information Publication or the Aeronautical Information Circular, the Gregorian calendar and Coordinated Universal Time shall be used as the temporal reference system.
- (3) Unless otherwise prescribed by the Authority, the International System of Units developed and maintained by the General Conference on Weights and Measures CGPM shall be used as the standard system of units of measurement.

## **6. Categories of Aerodromes**

In these Regulations aerodromes shall be categorized as follows:

- (a) category A comprising aerodromes and heliports designated for international flights;
- (b) category B comprising aerodromes available for use by domestic air traffic operations with maximum certificated take-off mass exceeding five thousand seven hundred kilogrammes and designated as a point of entry and exit other than international aerodrome opens for public use;
- (c) category C comprising aerodromes available for use only by domestic air traffic and open for public use of maximum certificated take-off mass not exceeding five thousand seven hundred kilogrammes and open for public use;
- (d) category D comprising aerodromes available for use only by domestic helicopters operations; and
- (e) category E comprising aerodromes and heliports available for use only by domestic air traffic of maximum certificated take-off mass not exceeding five thousand seven hundred kilogrammes and not open to public use or such aerodrome as may be determined by the Authority to be registered as a category E aerodrome using the methodology described in the Fourth Schedule of the Civil Aviation Certification, Licensing and Registration Regulations, Like for private aerodromes and individual use own only.

## **7. Requirements for Application for An Aerodrome Construction Permit**

- (1) A person shall not construct an aerodrome unless that person has a valid aerodrome construction permit issued under this Regulation.
- (2) An application for an aerodrome construction permit shall be considered for approval, where:
  - (a) the applicant holds a valid authorization from the authority for use of the place as an aerodrome; and
  - (b) the application is approved by the authority responsible for national environment Management.
- (3) The Authority shall prior to issuance of a construction permit, assess the suitability of the place proposed for construction taking into consideration:
  - (a) the proximity of the place to other aerodromes and landing areas including military aerodromes;
  - (b) obstacles, terrain and existing airspace restrictions; and
  - (c) that it is not against public interest that the place where the aerodrome is to be constructed shall be used as such.
- (4) The applicant for an aerodrome construction permit shall submit to the Authority for approval an application on a form and in a manner prescribed by the Authority in the applicable technical guidance material, accompanied by:
  - (a) a detailed design of the proposed construction including related architectural requirements approved by the authority;
  - (b) aerodrome data in accordance with the characteristics of the aircraft for which the aerodrome is intended; and

- (c) a topographical map of the proposed aerodrome site.

## **8. Issuance of Aerodrome Construction Permits**

The Authority shall issue an aerodrome construction permit to an applicant who meets the requirements and any other requirements as may be specified by the authority.

## **9. Design and Construction of Aerodromes**

- (1) An applicant for a construction permit shall ensure that the design and construction of the aerodrome is undertaken by a person registered by the relevant professional body.
- (2) The Authority shall inspect the site of an aerodrome during construction to ascertain compliance with these Regulations, the Civil Aviation Security Regulations, other applicable Laws and the terms of the aerodrome construction permit.

## **10. Requirement for Aerodrome Design**

- (1) The aerodrome operator shall ensure that architectural and infrastructure-related requirements for the optimum implementation of the applicable Civil Aviation Security Regulations shall be integrated into the design and construction of new facilities and alterations to existing facilities at an aerodrome.
- (2) The design of aerodromes shall take into account, where appropriate, land-use and environmental control measures.
- (3) An aerodrome design shall:
  - (a) indicate the physical characteristics in accordance with these regulations;
  - (b) indicate the obstacle limitation surfaces ;
  - (c) integrate security measures in accordance with the applicable Civil Aviation Security Regulations;
  - (d) indicate appropriate visual aids for navigation; and
  - (e) indicate appropriate equipment and installations.
- (4) The physical characteristics, obstacle limitation surfaces, visual aids and equipment and installations, required under sub-regulation (1) of this regulation shall:
  - (a) be appropriate to the critical aircraft characteristics for which the aerodrome intends to serve;
  - (b) be at the lowest meteorological minima for each runway;
  - (c) provide conditions for the safe operation of aircraft; and
  - (d) comply with the appropriate aerodrome design requirements prescribed in these Regulations.

## **11. Airport Design and Master Plan**

- (1) Development of aerodrome infrastructure shall be done in accordance with the master plan approved by the Authority.
- (2) The master plan shall:
  - (a) contain a schedule of priorities including a phased implementation plan; and
  - (b) be reviewed periodically to take into account current and future aerodrome traffic.

- (3) Aerodrome stakeholders, particularly aircraft operators, shall be consulted in order to facilitate the master planning process using a consultative and collaborative approach.
- (4) Architectural and infrastructure-related requirements for the optimum implementation of the Civil Aviation Security Regulations, shall be integrated into the design and construction of new facilities and alterations to existing facilities at an aerodrome.
- (5) The design of aerodromes shall take into account, where appropriate, land-use and environmental control measures.

## 12. Aerodrome Reference Code

- (1) An aerodrome reference code comprising a code number and a code letter shall be used for aerodrome planning purposes.
- (2) The aerodrome reference code shall be determined in accordance with the critical aero plane characteristics for which the aerodrome facility is intended.
- (3) The aerodrome reference code numbers and code letters required under sub-regulation (1) of this regulation shall have the meanings assigned to in Table 1.
- (4) The code number for element 1 shall be determined from Table 1 selecting the code number corresponding to the highest value of the aero plane reference field lengths of the aero planes for which the runway is intended.
- (5) The code letter for element 2 shall be determined from Table 1 by selecting the code letter which corresponds to the greatest wingspan of the aero planes for which the facility is intended.

**Table 1 Aerodrome Reference Code**

**Table 1: Code Number**

Code Element 1	
Code Number (1)	Aerodrome Reference Field Length (2)
1	Less than 800 m
2	800 m up to but not including 1 200 m
3	1 200 m up to but not including 1 800 m
4	1 800 m and over

**Table 1: Code Letter**

Code Element 2	
Code letter	Wingspan
A	Up to but not including 15 m
B	15 m up to but not including 24 m
C	24 m up to but not including 36 m
D	36 m up to but not including 52m
E	52 m up to but not including 65 m
F	65 m up to but not including 80 m

- (6) When the aerodrome accommodates an aero plane that exceeds the certificated characteristics of the aerodrome, the compatibility between the operation of the aero plane and aerodrome infrastructure and operations shall be assessed and appropriate measures developed and implemented in order to maintain an acceptable level of safety during operations.
- (7) Information concerning alternative measures, operational procedures and operating restrictions implemented at an aerodrome arising from sub regulation (1) shall be promulgated.

**13. Specific Procedures for Aerodrome Operations**

- (1) Where an aerodrome accommodates an aeroplane that exceeds the certificated characteristics of the aerodrome, an aerodrome operator shall assess the compatibility between the operation of the aeroplane and the aerodrome infrastructure structure and develop, implement appropriate measures in order to maintain an acceptable level of safety.
- (2) subject to sub-regulation (1) of this regulation the aerodrome operator shall include in the, aerodrome manual procedures for assessing the compatibility of the operation of a new aeroplane with the aerodrome and the aerodrome infrastructure and for development and implementing appropriate measures.
- (3) the procedures and measures developed in sub-regulation (2) shall be periodically reviewed to assess their continued validity.
- (4) the aerodrome operator shall notify the authority of promulgation information concerning alternative measures, operational procedures and operating restrictions implemented at an aerodrome arising from the assessment in sub-regulation (1).

**CHAPTER III**  
**INFORMATION TO BE REPORTED TO AERONAUTICAL INFORMATION SERVICES**  
**(ANNEX 14 CHAPTER 2)**

**14. Availability of Information**

- (1) An operator shall ensure that information relating to the aerodrome and its facilities, which is significant for the conduct of flights to and from the aerodrome, is available to the users of the aerodrome.
- (2) An operator shall be responsible for notifying the Aeronautical Information Services of any errors and omissions in the aeronautical information of operational significance, published in the Aeronautical Information Publication or Aeronautical Information Circular or in the NOTAM, and of any pending changes in the aerodrome or its facilities which are likely to affect this information.
- (3) An operator shall provide information on the following for the guidance of pilots and other operators:
  - (a) status of licensing, certification of the aerodrome;
  - (b) construction or maintenance work on or immediately adjacent to the manoeuvring area;
  - (c) unserviceable portions of any part of the manoeuvring area;
  - (d) the runway surface conditions when affected by water, damp, wet, water patches or flooded, as appropriate;
  - (e) parked aircraft or other objects on, or immediately adjacent to the taxiways;
  - (f) the presence of other temporary hazards;
  - (g) failure or irregular operation of any part of the aerodrome lighting system of the aerodrome main and secondary power supplies;
  - (h) failure, irregular operation and changes in the operational status of any electronic approach or navigation aid, or aeronautical communication facility;
  - (i) failures and changes in the runway visual range observer system; and
  - (j) any other information of operational significance.

**15. Action Required for Occurrences of Operational Significance Other Than Those Involving Electronic Aids and Communication Facilities**

- (1) Where any of the following conditions occur or are anticipated, an operator shall take immediate action to amend the information contained in the Aeronautical Information Circular and where necessary, promulgate the change by NOTAM through the Aeronautical Information Services using the Aeronautical Information Services address notified in the Aeronautical Information Circular:
  - (a) changes in the availability of the manoeuvring area and changes in the runway Declared the Authority distance, except that increases in declared distances may only be made with the approval of the Authority;
  - (b) significant changes in aerodrome lighting and other visual aids;
  - (c) presence or removal of temporary obstructions to aircraft operation in the manoeuvring area;

- (d) presence of airborne hazards to air navigation;
  - (e) interruption, return to service or major changes to rescue facilities and firefighting services in terms of the new category of the rescue and firefighting service available at the aerodrome; except those permanent changes to the promulgated rescue firefighting category may only be made with the approval of the Authority;
  - (f) failure of or return to operation of hazard beacons and obstruction lights on or in the vicinity of the aerodrome;
  - (g) erection or removal of obstructions to air navigation, and erection or removal of significant obstacles in take-off, climb or approach areas;
  - (h) air displays, air races, parachute jumping, or any unusual aviation activity; and
  - (i) any other information of operational significance.
- (2) Where any of the conditions in sub-regulation (1) arises at short notice, an operator shall notify the Aeronautical Information Services for promulgation of a NOTAM.
  - (3) Where any of the conditions in sub-regulation (1) is intended, the operator shall make a written request to the Aeronautical Information Services, for the amendment of the Aeronautical Information Publication and Aeronautical Information Circular or for supplementary action.

**16. Action Required for Occurrences That Affect Electronic Aids and Communication Facilities**

- (1) An operator or a person in charge of a navigation facility shall initiate NOTAM action:
  - (a) for the establishment or withdrawal of electronic aids to air navigation; and
  - (b) for changes in the regularity or reliability of operation of any electronic aid to air navigation or aeronautical communication facility.
- (2) An operator or a person in charge of a navigation facility shall request for the NOTAM action or an amendment, a supplement of Aeronautical Information Publication or Aeronautical Information Circular directly from the Aeronautical Information Services or through channels established by the Authority.

**17. Aeronautical Data Reporting**

- (1) An operator shall provide to the Authority for promulgation, accurate aeronautical data as specified in these Regulations.
- (2) An operator shall ensure that aerodrome related aeronautical data is adequate and accurate and that the integrity of the data is maintained and protected throughout the data process from survey or origin up to the next intended user.
- (3) An operator shall determine and report aerodrome related aeronautical data in accordance with the accuracy and integrity requirements of the Civil Aviation, Aeronautical Information Services Regulations while taking into account the established quality management system requirements.

- (4) Accuracy requirements for aeronautical data shall be based upon a ninety-five per cent confidence level and in that respect, three types of positional data, namely; surveyed points, calculated points and declared points shall be identified.
- (5) Aerodrome mapping data shall be made available to the aeronautical information services for aerodromes in category A where safety or performance-based operations suggest possible benefits.
- (6) Where made available in accordance with these regulations, the selection of the aerodrome mapping data features to be collected shall be made with consideration of the intended applications.
- (7) Where made available in accordance with these regulations, aerodrome mapping data shall comply with the accuracy and integrity requirements specified in by the applicable Civil Aviation Aeronautical Information Service regulation.
- (8) Subject to sub-regulation (7), the following classification and data integrity levels shall apply:
  - (a) for routine data: avoid corruption throughout the processing of the data;
  - (b) for essential data: assure corruption does not occur at any stage of the entire process and may include additional processes as needed to address potential risks in the overall system architecture to further assure data integrity at this level; and
  - (c) for critical data: assure corruption does not occur at any stage of the entire process and include additional integrity assurance procedures to fully mitigate the effects of faults identified by thorough analysis of the overall system architecture potential data integrity risk.

#### **CHAPER IV**

##### **AERODROME DATA (ANNEX 14 CHAPTER 2)**

#### **18. Aerodrome Data and Related Information**

The aerodrome operator shall measure and describe the following data, as appropriate, for each facility provided on an aerodrome:

- (a) **Runway:** true bearing to one-hundredth of a degree, designation number, length, width, displaced threshold location to the nearest meter or foot, slope, surface type, type of runway and, for a precision approach runway category I, the existence of an obstacle free zone when provided:
- (b) **Strip, Runway End Safety Area, Stop Way:** length, width to the nearest meter or foot, surface type and arresting system — location which runway end and description;
- (c) **Taxiway:** designation, width, surface type: and
- (d) **Apron:** surface type, aircraft packed.

#### **19. Aeronautical Data**

- (1) An aerodrome operator shall determine and report aerodrome-related aeronautical data shall be in accordance with the accuracy and integrity requirements set forth in the applicable Civil Aviation Aeronautical Information Services Regulations, while taking into account the established quality system procedures.
- (2) The accuracy requirements for aeronautical data shall be based upon a 95 per cent confidence level and in that respect, three types of positional data shall be identified:
  - (a) surveyed points e.g., runway threshold;
  - (b) calculated points mathematical calculations from the known surveyed points of points in space, fixes; and
  - (c) declared points e.g., flight information region boundary points.
- (3) The aerodrome operator shall make available to the aeronautical information services aerodrome mapping data for aerodromes where safety and/or performance-based operations suggest possible benefits.
- (4) Where made available in accordance with sub-regulation (3), the selection of the aerodrome mapping data features to be collected shall be made with consideration of the intended applications.
- (5) Where made available in accordance with sub-regulation (3), aerodrome mapping data shall comply with the accuracy and integrity requirements specified in the applicable Civil Aviation Aeronautical Information Services Regulations.
- (6) Integrity of aeronautical data shall be maintained throughout the data process from survey, origin to the next intended user and based on the applicable integrity classification, the validation and verification procedures shall:
  - (a) for routine data: avoid corruption throughout the processing of the data;
  - (b) for essential data: assure corruption does not occur at any stage of the entire process and may include additional processes as needed to address potential risks in the overall system architecture to further assure data integrity at this level; and
  - (c) for critical data: assure corruption does not occur at any stage of the entire process and include additional integrity assurance procedures to fully mitigate the effects of faults identified by thorough analysis of the overall system architecture as potential data integrity risks.
- (7) Protection of electronic aeronautical data while stored or in transit shall be totally monitored by the cyclic redundancy check CRC and to achieve protection of the integrity level of critical and essential aeronautical data as classified in sub-regulation (6), a 32- or 24-bit CRC algorithm shall apply, respectively.
- (8) To achieve protection of the integrity level of routine aeronautical data as classified in sub-regulation (6), (a) 16-bit (CRC) algorithm shall apply.
- (9) Geographical coordinates indicating latitude and longitude shall be determined and reported to the aeronautical information services authority in terms of the World Geodetic System — 1984 (WGS-84) geodetic reference datum, identifying those geographical coordinates which have been transformed into WGS-84 coordinates by mathematical means and whose accuracy of original field work does not meet the

requirements of the applicable Civil Aviation Aeronautical Information services Regulations.

- (10) The order of accuracy of the field work shall be such that the resulting operational navigation data for the phases of flight shall be within the maximum deviations, with respect to an appropriate reference frame, as indicated in the applicable Civil Aviation Aeronautical Information Services regulations. An appropriate reference frame is that which enables WGS-84 to be realized on a given aerodrome and with respect to which all coordinate data are related.
- (11) In addition to the elevation (referenced to mean sea level) of the specific surveyed ground positions at aerodromes, geoid undulation (referenced to the WGS-84 ellipsoid) for those positions as indicated in the applicable Civil Aviation Aeronautical Information Services regulations shall be determined and reported to the aeronautical information services.

## **20. Aerodrome Reference Point**

- (1) An aerodrome operator shall establish reference point for an aerodrome.
- (2) The aerodrome reference point referred to in sub-regulation (1) of this regulation shall be located near the initial or planned geometric center of the aerodrome and shall normally remain where first established.
- (3) The position of the aerodrome reference point shall be measured and reported to the aeronautical information services authority in degrees, minutes and seconds.

## **21. Aerodrome and Runway Elevations**

- (1) An aerodrome operator shall ensure that the aerodrome elevation and geoid undulation at the aerodrome elevation position is measured to the accuracy of one-half metre or foot and reported to the aeronautical information services authority.
- (2) For an aerodrome used by international civil aviation for non-precision approaches, the elevation and geoid undulation of each threshold, the elevation of the runway end and any significant high and low intermediate points along the runway shall be measured to the accuracy of one-half meter or foot and reported to the aeronautical information services authority.
- (3) For precision approach runway, the elevation and geoid undulation of the threshold, the elevation of the runway end and the highest elevation of the touchdown zone shall be measured to the accuracy of one-quarter meter or foot and reported to the aeronautical information services authority.
- (4) Geoid undulation shall be measured in accordance with the appropriate system of coordinates.

## **22. Aerodrome Reference Temperature**

- (1) An aerodrome operator shall determine aerodrome reference temperature for the aerodrome in degree Celsius.
- (2) The aerodrome reference temperature shall be the monthly mean of the daily maximum temperatures for the hottest month of the year, the hottest month being that which has

the highest monthly mean temperature and this temperature shall, where possible be averaged over a period of years.

### **23. Aerodrome Dimensions and Related Information**

- (1) An aerodrome operator shall measure or describe the following data, as appropriate, for each facility provided on an aerodrome:
  - (a) runway — true bearing to one-hundredth of a degree, designation number, length, width, displaced threshold location to the nearest meter or foot, slope, surface type, type of runway and, for a precision approach runway category I, the existence of an obstacle free zone when provided;
  - (b) width to the nearest meter or foot, surface type of:
    - (i) strip
    - (ii) runway end safety area length
  - (c) stop way;
  - (d) taxiway — designation, width, surface type;
  - (e) apron — surface type, aircraft stands;
  - (f) the boundaries of the air traffic control service;
  - (g) clearway — length to the nearest meter or foot, ground profile;
  - (h) visual aids for approach procedures, marking and lighting of runways, taxiways and aprons, other visual guidance and control aids on taxiways and aprons, including taxi-holding positions and stop bars, and location and type of visual docking guidance systems;
  - (i) location and radio frequency of any VOR aerodrome checkpoint;
  - (j) location and designation of standard taxi-routes; and
  - (k) distances to the nearest meter or foot of localizer and glide path elements comprising an instrument landing system ILS or azimuth and elevation antenna of a microwave landing system MLS in relation to the associated runway extremities.
- (3) The geographical coordinates of each threshold shall be measured and reported to the aeronautical information services authority in degrees, minutes, seconds and hundredths of seconds.
- (4) The geographical coordinates of appropriate taxiway center line points shall be measured and reported to the aeronautical information services authority in degrees, minutes, seconds and hundredths of seconds.
- (5) The geographical coordinates of each aircraft stand shall be measured and reported to the aeronautical information services authority in degrees, minutes, seconds and hundredths of seconds.
- (6) The geographical coordinates of obstacles in Area 2 the part within the aerodrome boundary and in Area 3 shall be measured and reported to the aeronautical information services authority in degrees, minutes, seconds and tenths of seconds and in addition, the top elevation, type, marking and lighting where any of obstacles shall be reported to the aeronautical information services authority.

### **24. Strength of Pavements**

- (1) This regulation is applicable until 27 November 2025.
- (2) The aerodrome operator shall determine the bearing strength of a pavement.
- (3) The bearing strength of a pavement intended for aircraft of apron ramp mass greater than 5 700 kg shall be made available using the aircraft classification number — pavement classification number ACN-PCN method by reporting all of the following information:
  - (a) the pavement classification number PCN;
  - (b) pavement type for ACN-PCN determination;
  - (c) subgrade strength category;
  - (d) maximum allowable tire pressure category or maximum allowable tire pressure value; and
  - (e) evaluation method and where necessary, PCNs may be published to an accuracy of one-tenth of a whole number.
- (4) The pavement classification number PCN reported shall indicate that an aircraft with an aircraft classification number ACN equal to or less than the reported PCN can operate on the pavement subject to any limitation on the tire pressure, or aircraft all-up mass for specified aircraft type(s).
- (5) Different PCNs may be reported where the strength of the pavement is subject to significant seasonal variation.
- (6) The ACN of an aircraft shall be determined in accordance with the standard procedures associated with the ACN-PCN method.
- (7) For the purposes of determining the ACN, the behavior of a pavement shall be classified as equivalent to a rigid or flexible construction.
- (8) Information on pavement type for ACN-PCN determination, subgrade strength category, maximum allowable tire pressure category and evaluation method shall be reported using the following codes:
 

(a)	Pavement type for ACN-PCN determination	Code
	Rigid pavement	R
	Flexible pavement	F
(b)	Subgrade strength	category
	Code	
	High strength: characterized by $K = 150 \text{ MN/m}^3$ and representing all $K$ values above <span style="margin-left: 100px;">A</span>	
	120 $\text{MN/m}^3$ for rigid pavements, and by $\text{CBR} = 15$ and representing all $\text{CBR}$ values	
	Above 13 for flexible pavements.	
	Medium strength: characterized by $K = 80 \text{ MN/m}^3$ and representing a range in $K$ of 60 to <span style="margin-left: 100px;">B</span>	
	120 $\text{MN/m}^3$ for rigid pavements, and by $\text{CBR} = 10$ and representing a range in $\text{CBR}$ of 8 to	
	13 for flexible pavements.	

Low strength: characterized by  $K = 40 \text{ MN/m}^3$  and representing a range in  $K$  of 25 to C  
 $60 \text{ MN/m}^3$  for rigid pavements, and by  $\text{CBR} = 6$  and representing a range in  $\text{CBR}$  of 4 to 8 for flexible pavements.

Ultra-low strength: characterized by  $K = 20 \text{ MN/m}^3$  and representing all  $K$  values below D  
 $25 \text{ MN/m}^3$  for rigid pavements, and by  $\text{CBR} = 3$  and representing all  $\text{CBR}$  values below 4  
 For flexible pavements.

- (c) Maximum allowable tire pressure category  
 Code
- |                                      |   |
|--------------------------------------|---|
| Unlimited: no pressure limit         | W |
| High: pressure limited to 1.75 MPa   | X |
| Medium: pressure limited to 1.25 MPa | Y |
| Low: pressure limited to 0.50 MPa    | Z |

- (d) Evaluation method  
 Code
- Technical evaluation: representing a specific study of the pavement characteristics and T  
 application of pavement behavior technology.  
 Using aircraft experience: representing a knowledge of the specific type and mass of U Aircraft satisfactorily being supported under regular use.

(9) The following examples shall be used to illustrate how pavement strength data are reported under the ACN-PCN method:

- (a) Where the bearing strength of a rigid pavement, resting on a medium strength subgrade, has been assessed by technical evaluation to be PCN 80 and there is no tire pressure limitation, then the reported information shall be:

PCN 80 / R / B / W / T

- (b) Where the bearing strength of a composite pavement, behaving like a flexible pavement and resting on a high strength subgrade, has been assessed by using aircraft experience to be PCN 50 and the maximum tire pressure allowable is 1.25 MPa, then the reported information shall be:

PCN 50 / F / A / Y / U

- (c) Where the bearing strength of a flexible pavement, resting on a medium strength subgrade, has been assessed by technical evaluation to be PCN 40 and the maximum allowable tire pressure is 0.80 MPa, then the reported information shall be:

PCN 40 / F / B / 0.80 MPa / T

- (d) Where a pavement is subject to a B747-400 all-up mass limitation of 390 000 kg, then the reported information shall include a note to the effect that the reported PCN is subject to a B747-400 all-up mass limitation of 390 000 kg.

- (10) An aerodrome operator in coordination with the Authority may establish the criteria to regulate the use of a pavement by an aircraft with an ACN higher than the PCN reported for that pavement in accordance with sub-regulations (2) and (3).
- (11) The bearing strength of a pavement intended for aircraft of apron (ramp) mass equal to or less than 5700 kg shall be made available by reporting the following information:
  - (a) maximum allowable aircraft mass; and
  - (b) maximum allowable tire pressure.  
e.g.: 4 000 kg/0.50 MPa

## **25. Flight Altimeter Check Location**

- (1) An aerodrome operator shall establish one or more pre-flight altimeter check locations for an aerodrome. **Pre**
- (2) Subject to sub-regulation (1) pre-flight check location shall be located on an apron to enable an altimeter check to be made prior to obtaining taxi clearance and to eliminate the need for stopping for that purpose after leaving the apron, in which case, an entire apron can serve as a satisfactory altimeter check location.
- (3) The elevation of a pre-flight altimeter check location shall be given as the average elevation, rounded to the nearest meter or foot, of the area on which it is located.
- (4) The elevation of any portion of a pre-flight altimeter check location shall be within 3 m (10ft) of the average elevation for that location.

## **26. Declared Distances**

- (1) An aerodrome operator shall continue to the nearest metre or foot for a runway intended for use by international commercial air transport the following distances:
  - (a) take-off run available;
  - (b) take-off distance available;
  - (c) accelerate-stop distance available; and
  - (d) landing distance available.
- (2) Declared distances shall be calculated in accordance with the Eighth Schedule to these regulations.

## **27. Condition of the Movement Area and Related Facilities**

- (1) The aerodrome operator shall provide information on the condition of the movement area and the operational status of related facilities to the appropriate aeronautical information services units, and similar information of operational significance to the air traffic services units, to enable the units to provide the necessary information to arriving and departing aircraft.
- (2) The information referred to in sub-regulation (1) shall be kept up to date and changes in conditions reported without delay.
- (3) The aerodrome operator shall monitor the condition of the movement area and the operational status of related facilities, and provide reports on matters of operational significance affecting aircraft and aerodrome operations to aeronautical information

service provider and air traffic control unit in order the appropriate action to be taken in respect of at least the following:

- (a) construction or maintenance work;
  - (b) rough or broken surfaces on a runway, a taxiway or an apron;
  - (c) water on a runway, a taxiway or an apron;
  - (d) other contaminants on a runway, taxiway or apron such as mud, dust, sand, volcanic ash, oil and rubber;
  - (e) other temporary hazards, including parked aircraft;
  - (f) failure or irregular operation of part or all of the aerodrome visual aids; and
  - (g) failure of the normal or secondary power supply.
- (4) subject to sub-regulations (1) and (3), the following inspections shall be carried out each day:
- (a) For the movement area shall be carried out each day at least once where the code number is 1 or 2 and at least twice where the code number is 3 or 4.
  - (b) For the runway(s), in addition to (a) whenever the runway surface conditions may have changed significantly due to meteorological conditions.
- (5) The aerodrome operator shall ensure that personnel assessing and reporting runway surface conditions required in sub-regulation (2) are conducted by appropriately trained and competent personnel to perform such duties.

## **28. Runway Surface Condition(S) For Use in The Runway Condition Report**

- (1) The aerodrome operator shall assess and report the runway surface condition through a runway condition code (RWYCC) and a description using the following terms as applicable:
- STANDING WATER  
WATER ON TOP OF COMPACTED SNOW  
WET  
WET ICE  
WET SNOW  
WET SNOW ON TOP OF COMPACTED SNOW  
WET SNOW ON TOP OF ICE  
CHEMICALLY TREATED  
LOOSE SAND
- (2) Whenever an operational runway is contaminated, the aerodrome operator shall assess and report to aerodrome users the contaminant depth and coverage over each third of the runway
- (3) When friction measurements are used as part of the overall runway surface assessment on contaminated surfaces, the friction measuring device shall meet the standard set or agreed by the Authority.
- (4) The aerodrome operator shall make available information that a runway or portion is slippery wet

- (5) The aerodrome operator shall notify relevant aerodrome users when the friction level of a paved runway or portion is less than the minimum friction level specified by the Authority.

**29. Responsibility for Removal of Disabled Aircraft**

- (1) The aerodrome operator shall provide the telephone number and email address of the office of the aerodrome coordinator responsible for the removal of an aircraft disabled on or adjacent to the movement area and shall, on request, make available, this information to aircraft operators.
- (2) Information concerning the capability to remove an aircraft disabled on or adjacent to the movement area shall be made available and such capability to remove a disabled aircraft may be expressed in terms of the largest type of aircraft which the aerodrome is equipped to remove.

**30. Information On Level of Protection of Rescue and Fire Fighting**

- (1) An aerodrome operator shall provide information concerning the level of protection provided at an aerodrome for aircraft rescue and firefighting purposes.
- (2) The level of protection available at an aerodrome shall be expressed in terms of the category of the rescue and firefighting services in accordance with the types and amounts of extinguishing agents available at the aerodrome in the following manner.
  - (a) Changes in the level of protection normally available at an aerodrome for rescue and firefighting services caused by changes in the availability of extinguishing agents, equipment to deliver the agents or personnel to operate the equipment, among others, shall be notified to the appropriate air traffic services units and aeronautical information services units to enable those units to provide the necessary information to arriving and departing aircraft in the form of stating the revised RFF category
  - (b) When such a change has been corrected, the appropriate air traffic services units and aeronautical information services units shall be advised accordingly.
- (3) A change shall be expressed in terms of the new category of the rescue and fire firefighting service available at the aerodrome.

**31. Visual Approach Slope Indicator Systems**

The aerodrome operator shall make available the following information concerning a visual approach slope indicator system installation as follows:

- (a) associated runway designation number;
- (b) type of system - for a, PAPI or APAPI installation, the side of the runway on which the lights are installed, that is left or right, shall be given; and
- (c) where the axis of the system is not parallel to the runway center line, the angle of displacement and the direction of displacement, that is left or right, shall be indicated; nominal approach slope angle(s). for a PAPI and an APAPI shall be angle  $(B + C) \div 2$  and  $(A + B) \div 2$ , as in Figure 5-20; and minimum eye height(s) over the threshold of

the on-slope signal(s) for a PAPI this shall be the setting angle of the third unit from the runway minus 2 minutes, that is. angle B minus 2 minutes, and for an APAPI this shall be the setting angle of the unit farther from the runway minus 2 minutes, that is. angle A minus 2 minutes.

### **32. Coordination Between Aeronautical Information Services and Aerodrome Authorities**

- (1) The aerodrome operator shall for the purpose of ensuring the aeronautical information services units obtain information to enable them to provide up-to-date pre-flight information and to meet the need for in-flight information, make arrangements with the aeronautical information services and the authority to report to the responsible aeronautical information services unit, with a minimum of delay the following:
  - (a) information on the status of certification of aerodromes and aerodrome conditions;
  - (b) the operational status of associated facilities, services and navigation aids within their area of responsibility; and
  - (c) any other information considered to be of operational significance.
- (2) The aerodrome operator shall ensure that; Before introducing changes to the air navigation system, due account is taken by the services responsible for such changes of the time needed by aeronautical information services for the preparation, production and issue of relevant material for promulgation.
- (3) There is timely provision of the information to aeronautical information services and close coordination between those services concerned
- (4) An aeronautical information service provider shall ensure that; cchanges to aeronautical information that affects charts or computer-based navigation systems qualify to be notified by the aeronautical information regulation and control AIRAC system.
- (5) The predetermined, internationally agreed AIRAC effective dates in addition to 14 days Postage time are observed by the responsible aerodrome services when submitting the raw information data to aeronautical information services.
- (6) The aerodrome services responsible for the provision of raw aeronautical information/data to the aeronautical information services shall do that while taking into account accuracy and integrity requirements required to meet the needs of the needs of the end user of aeronautical data.

## **CHAPTER V AERODROMES PHYSICAL CHARACTERISTICS**

### **33. Application**

The Specifications under this Chapter shall only apply to land aerodromes.

#### **Conditions for Operating an Aerodrome**

A person shall not operate an aerodrome licensed, certificated or registered under the applicable Civil Aviation Certification, Licensing & Registration of Aerodrome Regulations unless the

facilities and characteristics of the aerodrome are effectively related and match the needs of the aircraft for which the aerodrome is intended.

### **34. Standards for Physical Characteristics of An Aerodrome**

A person shall not operate an aerodrome unless the physical characteristics of the aerodrome comply with these regulations.

#### **Runways**

### **35. Runways Number and Orientation of Runways**

The aerodrome operator shall ensure that:

- (a) The number and orientation of a runway at an aerodrome is such that, the usability factor of the aerodrome is not less than 95 per cent for the aircraft for which the aerodrome is intended to serve, taking into account the wind distribution for the location.
- (b) The siting and orientation of runways at an aerodrome shall be such that the arrival and departure tracks minimize interference with areas approved for residential use and other noise-sensitive areas close to the aerodrome in order to avoid future noise problems.
- (c) When a new instrument runway is being located, particular attention shall be given to areas over which aircraft shall be required to fly when following instrument approach and missed approach procedures, so as to ensure that obstacles in these areas or other factors shall not restrict the operation of the aircraft for which the runway is intended.

### **36. Choice of Maximum Permissible Cross-Wind Components**

- (1) the aerodrome operator shall, in determining the number and orientation of runways as required by regulation 100 (1) ensure that the crosswind component for aircraft landing and taking off does not exceed the cross-wind components:
  - (a) 37 km/h (20 kts) in the case of aircraft whose reference field length is 1500 m or over, except that when poor runway braking action owing to an insufficient longitudinal coefficient of friction is experienced with some frequency, a crosswind component not exceeding 24 km/h (13 kts) shall be assumed;
  - (b) 24 km/h (13 kts) in the case of aircraft whose reference field length is 1200 m or up to but not including 1 500 m; and
  - (c) 19 km/h (10 kts) in the case of aircraft whose reference field length is less than 1200 m.
- (2) Subject to sub-regulation (1), factors that may affect the calculation of the estimate of the usability factor and allowances to be made shall take into account of the effect of unusual circumstance and shall include:
  - (a) type of operation;
  - (b) climatological conditions including wind distribution, wind statistics and crosswind components;
  - (c) Topography of the aerodrome site, aircraft approach paths, and surroundings including:
    - (i) obstacle limitation surfaces, as applicable
    - (ii) current and future land use

- (iii) construction costs
- (iv) Visual and non-visual aids
- (d) Air traffic in the vicinity of the aerodrome including; proximity of other aerodromes or air traffic services routes traffic density air traffic control procedures where applicable and missed approach procedures

**37. Data to be Used for the Calculation of the Runway Usability Factor**

- (1) The selection of data to be used for the calculation of the runway usability factor shall be based on reliable wind distribution statistics that extend over a period of not less than five years with wind observations made at least eight times daily and spaced at equal intervals of time.
- (2) Notwithstanding the requirements of sub-regulation (1) wind distribution statistics of a shorter period may be used for runways in category E aerodromes as determined by the operator and accepted by the Authority.

**38. Location of Threshold**

- (1) Unless operational considerations justify the choice of another location, the runway threshold shall be located at the extremity of a runway.
- (2) In determining that no obstacles penetrate above the approach surface, account shall be taken of mobile objects (vehicles on roads, trains, etc.) at least within that portion of the approach area within 1200 m longitudinally from the threshold and of an overall width of not less than 150 m.
- (3) When it is necessary to displace a threshold, either permanently or temporarily, from its normal location, the operator shall take into account the various factors which may have a bearing on the location of the threshold.
- (4) Where a displacement is due to an unserviceable runway condition, a cleared and graded area of at least 60 m in length shall be made available between the unserviceable area and the displaced threshold and an additional distance shall be provided to meet the requirements of the runway end safety area as appropriate.
- (3) Pursuant to sub-regulation (3), factors to be considered in the determination of the location of a displaced threshold shall be:
  - (a) obstacles in the approach surface;
  - (b) landing distance available;
  - (c) type of aircraft for which the runway is intended;
  - (d) visibility and cloud base conditions;
  - (e) obstacle clearance limit in the case of precision approach runways; and
  - (f) provision for obstacle free surfaces.

**39. Determination of Actual Length of Runways**

- (1) Except as provided in sub-regulations (3) below, the actual runway length to be provided for a Primary Runway shall be adequate to meet the operational requirements of the aeroplanes for which the runway is intended and shall not be less than the longest length determined by applying the corrections for local conditions to the operations and

performance characteristics of the relevant aeroplanes, including elevation, temperature, runway slope, humidity and the runway surface characteristics.

- (2) The specification sub-regulation (1) of this regulation shall not necessarily mean providing for operations by the critical aeroplane at its maximum mass.
- (3) Both take-off and landing requirements need to be considered when determining the length of runway to be provided and the need for operations to be conducted in both directions of the runway.
- (4) The length of a secondary runway shall be determined in accordance with sub-regulation (1) except that consideration shall only be given to the needs of those aeroplanes which require to use the secondary runway in addition to other runways in order to obtain a usability factor of at least 95 percent.
- (5) Where a runway is associated with a stop-way or clearway an actual runway length less than that resulting from application of sub-regulations (1) or (4), of this regulation as appropriate, may be considered satisfactory, but in such a case any combination of runway, stop-way and clearway provided shall permit compliance with the operational requirements for take-off and landing of the aircraft the runway is intended to serve.
- (6) The use of stepways and clearways shall be as described in the eighth schedule to these regulations.

#### 40. Determination of Width of Runway

- (1) The width of a runway shall not be less than the appropriate dimension specified in the following tabulation:

##### Outer Main Gear Wheel Span (OMGWS)

Code number	Up to but not including 4.5	4.5 m up to but not including 6 m	6 m up to but not including 9 m	9 m up to but not including 15 m
1 <sup>a</sup>	18 m	18 m	23 m	-
2a	23 m	23 m	30 m	-
3	30 m	30 m	30 m	45 m
4	-	-	45 m	45 m

- (a) The width of a precision approach runway shall be not less than 30 m where the code number is 1 or 2.
- (2) The width of a precision approach runway shall be not less than 30 m where the code number is 1 or 2.

#### 41. Determination of Minimum Distance Between Parallel Runways

- (1) Where parallel non-instrument runways are intended for simultaneous use, the minimum distance between their centre lines shall be:
  - (a) 210 m where the higher code number is 3 or 4;
  - (b) 150 m where the higher code number is 2; and
  - (c) 120 m where the higher code number is 1.
- (2) Where parallel instrument runways are intended for simultaneous use, the minimum distance between their center lines shall be:
  - 1 035 m for independent parallel approaches;
  - 915 m for dependent parallel approaches;
  - 760 m for independent parallel departures;
  - 760 m for segregated parallel operations;
 except that:
  - (a) for segregated parallel operations the specified minimum distance:
    - (i) may be decreased by 30 m for each 150 m that the arrival runway is staggered toward the arriving aircraft, to a minimum of 300 m; and
    - (ii) shall be increased by 30 m for each 150 m that the arrival runway is staggered away from the arriving aircraft;
  - (b) for independent parallel approaches, combinations of minimum distances and associated conditions may be applied when it is determined that such combinations shall not adversely affect the safety of aircraft operations.

#### **42. Slopes On Runways**

- (1) The longitudinal slope of a runway shall be computed by dividing the difference between the maximum and minimum elevation along the runway centre line by the runway length and shall not exceed:
  - (a) 1 per cent where the code number is 3 or 4; and
  - (b) 2 per cent where the code number is 1 or 2.
- (2) The longitudinal slopes along any portion of a runway shall not exceed:
  - (a) 1.25 per cent where the code number is 4, except that for the first and last quarter of the length of the runway the longitudinal slope shall not exceed 0.8 per cent;
  - (b) 1.5 per cent where the code number is 3, except that for the first and last quarter of the length of a precision approach runway category II or III the longitudinal slope shall not exceed 0.8 per cent; and
  - (c) 2 per cent where the code number is 1 or 2.
- (3) Where longitudinal slope changes cannot be avoided, the slope change between two consecutive slopes shall not exceed:
  - (a) 1.5 per cent where the code number is 3 or 4; and
  - (b) 2 per cent where the code number is 1 or 2.
- (4) The transition from one longitudinal slope to another shall be accomplished by a curved surface with a rate of change not exceeding:

- (a) 0.1 per cent per 30 m (minimum radius of curvature of 30 000 m) where the code number is 4;
  - (b) 0.2 per cent per 30 m (minimum radius of curvature of 15 000 m) where the code number is 3; and
  - (c) 0.4 per cent per 30 m (minimum radius of curvature of 7 500 m) where the code number is 1 or 2.
- (5) Where slope changes cannot be avoided, they shall be such that there shall be an unobstructed line of sight from:
- (a) any point 3 m above a runway to all other points 3 m above the runway within a distance of at least half the length of the runway where the code letter is C, D, E or F;
  - (b) any point 2 m above a runway to all other points 2 m above the runway within a distance of at least half the length of the runway where the code letter is B; and
  - (c) any point 1.5 m above a runway to all other points 1.5 m above the runway within a distance of at least half the length of the runway where the code letter is A.
- (6) In which case, consideration shall have to be given to providing an unobstructed line of sight over the entire length of a single runway where a full-length parallel taxiway is not available and where an aerodrome has intersecting runways, additional criteria on the line of sight of the intersection area shall need to be considered for operational safety.
- (7) Undulations or appreciable changes in slopes located close together along a runway shall be avoided and the distance between the points of intersection of two successive curves shall not be less than:
- (a) the sum of the absolute numerical values of the corresponding slope changes multiplied by the appropriate value as follows:
    - (i) 30 000 m where the code number is 4;
    - (ii) 15 000 m where the code number is 3; and
    - (iii) 5 000 m where the code number is 1 or 2; or
  - (b) 45 m; whichever is greater.
- (8) To promote the most rapid drainage of water, the runway surface shall, where practicable, be cambered except where a single cross fall from high to low in the direction of the wind most frequently associated with rain shall ensure rapid drainage.
- (9) The transverse slope shall where possible, be:
- (a) 1.5 per cent where the code letter is C, D, E or F; and
  - (b) 2 per cent where the code letter is A or B;
- (10) but in any event shall not exceed 1.5 per cent or 2 per cent, as applicable, nor be less than 1 percent except at runway or taxiway intersections where flatter slopes may be necessary; and
- (11) For a cambered surface the transverse slope on each side of the centre line shall be symmetrical.

- (12) The transverse slope shall be substantially the same throughout the length of a runway except at an intersection with another runway or a taxiway where an even transition shall be provided taking into account the need for adequate drainage.

#### **43. Strength of Runways**

Aerodrome operator shall ensure that runway is shall be capable of withstanding the traffic of aircraft for which the runway is intended to serve.

#### **44. Surface of Runways**

- (1) The surface of a runway shall be constructed without irregularities that shall impair the runway surface friction characteristics or otherwise adversely affect the take-off or landing of an aeroplane.
- (2) A paved runway shall be constructed or resurfaced so as to provide surface friction characteristics at or above the minimum friction level specified by the Authority.
- (3) The surface of a paved runway shall be evaluated when constructed or resurfaced to determine that the surface friction characteristics achieve the design objectives.
- (4) Measurements of the surface friction characteristics of a new or resurfaced paved runway shall be made with a continuous friction measuring device using self-wetting features.
- (5) The average surface texture depth of a new surface shall be not less than 1.0 mm, taking into consideration macrotexture and micro texture in order to provide the required surface friction characteristics.
- (6) When the surface is grooved or scored, the grooves or scorings shall be either perpendicular to the runway centre line or parallel to non-perpendicular transverse joints, where applicable.

#### **45. Runway Shoulders**

- (1) An aerodrome operator shall provide runway shoulders for a runway where the code letter is D, E or F.
- (2) For aeroplanes with OMGWS from 9 m up to but not including 15 m, the runway shoulders shall extend symmetrically on each side of the runway so that the overall width of the runway and its shoulders is not less than:
  - (a) 60 m where the code letter is D or E;
  - (b) 60 m where the code letter is F with two- or three-engine aero planes; and
  - (c) 75 m where the code letter is F with four (or more)-engine aero planes.
- (3) The surface of the shoulder that abuts the runway shall be flush with the surface of the runway and its transverse slope shall not exceed 2.5 percent. The portion of a runway shoulder between the runway edge and a distance of 30 m from the runway centre line shall be prepared or constructed so as to be capable:
  - (a) in the event of an aeroplane running off the runway, of supporting the aeroplane without inducing structural damage to the aeroplane; and
  - (b) of supporting ground vehicles which may operate on the shoulder.

- (4) A runway shoulder shall be prepared or constructed so as to resist erosion and the ingestion of the surface material by aeroplane engines.
- (5) Runway shoulders for code letter F aeroplanes shall be paved to a minimum overall width of runway and shoulder of not less than 60 m.

**46. Runway Turn Pads**

- (1) Where the end of a runway is not served by a taxiway or a taxiway turnaround and where the code letter is D, E, or F, an aerodrome operator shall provide a runway turn to facilitate a 180-degree turn of aeroplane as indicated in the figure below.

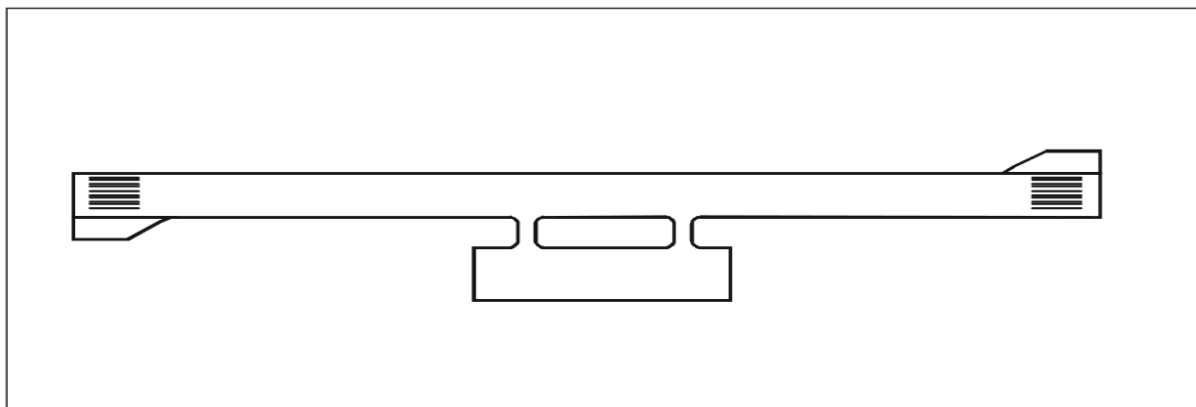

**Typical turn pad layout**

- (2) Where the end of a runway is not served by a taxiway or a taxiway turnaround and where the code letter is A, B, or C, a runway turn pad shall be provided to facilitate a 180-degree turn of aeroplanes.
- (3) The runway turn pad may be located on either the left or right side of the runway and adjoining the runway pavement at both ends of the runway and at some intermediate locations were deemed necessary.
- (4) The intersection angle of the runway turn pad with the runway shall not exceed 30 degrees.
- (5) The nose wheel steering angle to be used in the design of the runway turn pad shall not exceed 45 degrees.
- (6) The design of a runway turn pad shall be such that, when the cockpit of the aircraft for which the turn pad is intended remains over the turn pad marking, the clearance distance between any wheel of the aircraft landing gear and the edge of the turn pad shall be not less than that given by the following tabulation.

OMGWS				
	Up to but not including 4.5m	4.5m up to but not including 6m	6m up to but not including 9m	9m up to but not including 15m
Clearance	1.50 m	2.25 m	3 m <sup>a</sup> or 4 m <sup>b</sup>	4 m
<sup>a</sup> Where the turn pad is intended to be used by aeroplanes with a wheelbase less than 18 m.				
<sup>b</sup> Where the turn pad is intended to be used by aeroplanes with a wheelbase equal to or greater than 18 m.				

- (7) for the purpose of these regulations, wheel base means the distance from the nose gear to the geometric center of the main gear.
- (8) Where severe weather conditions and resultant lowering of surface friction characteristics prevail, a larger wheel-to-edge clearance of 6 m shall be provided where the code letter is E or F.
- (9) The longitudinal and transverse slopes on a runway turn pad shall be sufficient to prevent the accumulation of water on the surface and facilitate rapid drainage of surface water, and the slopes shall be the same as those on the adjacent runway pavement surface.
- (10) The strength of a runway turn pad shall be at least equal to that of the adjoining runway which it serves, due consideration being given to the fact that the turn pad shall be subjected to slow-moving traffic making hard turns and consequent higher stresses on the pavement and where a runway turn pad is provided with flexible pavement, the surface shall be capable of withstanding the horizontal shear forces exerted by the main landing gear tires during turning manoeuvres.
- (11) The surface of a runway turn pad shall not have surface irregularities that may cause damage to an aircraft using the turn pad.
- (12) The surface of a runway turn pad shall be so constructed or resurfaced as to provide surface friction characteristics at least equal to that of the adjoining runway.
- (13) The runway turn pads shall be provided with shoulders of such width as is necessary to prevent surface erosion by the jet blast of the most demanding aircraft for which the turn pad is intended, and any possible foreign object damage to the aeroplane engines, and as a minimum, the width of the shoulders shall be required to cover the outer engine of the most demanding aircraft and thus may be wider than the associated runway shoulders.
- (14) The strength of runway turn pad shoulders shall be capable of withstanding the occasional passage of the aircraft it is designed to serve without inducing structural damage to the aircraft and to the supporting ground vehicles that may operate on the shoulder.

#### **47. Runway Strips**

- (1) An aerodrome operator shall include a runway and any associated stop ways in a strip.
- (2) A strip shall extend before the threshold and beyond the end of the runway or stop way for a distance of at least:
  - (a) 60 m where the code number is 2, 3 or 4;
  - (b) 60 m where the code number is 1 and the runway is an instrument one; and
  - (c) 30 m where the code number is 1 and the runway is a non-instrument one.
- (3) A strip including a precision approach runway shall, wherever practicable, extend laterally to a distance of at least:
  - (a) 140 m where the code number is 3 or 4; and
  - (b) 70 m where the code number is 1 or 2; on each side of the center line of the runway and its extended center line throughout the length of the strip.
- (4) A strip including a non-precision approach runway shall extend laterally to a distance of at least:

- (a) 140 m where the code number is 3 or 4; and
  - (b) 70 m where the code number is 1 or 2; on each side of the center line of the runway and its extended center line throughout the length of the strip.
- (5) A strip including a non-instrument runway shall extend on each side of the centre line of the runway and its extended centre line throughout the length of the strip, to a distance of at least:
- (a) 75 m where the code number is 3 or 4;
  - (b) 40 m where the code number is 2; and
  - (c) 30 m where the code number is 1.
- (6) An object situated on a runway strip which may endanger aircraft shall be regarded as an obstacle and shall, as far as practicable, be removed.
- (7) The aerodrome operator shall give consideration: -
- (a) to the location and design of drains on a runway strip to prevent damage to an aeroplane accidentally running off a runway;
  - (b) where open -air or covered storm water conveyances are installed; consideration shall have to be given to ensure that their structure does not extend surrounding ground so as not to be considered an obstacle;
  - (c) to design and maintenance of an open-air storm water conveyance in order to prevent wildlife attraction, notably birds; and
  - (d) where needed, it can be covered by a net.
- (8) No fixed object, other than visual aids required for air navigation or those required for aircraft safety purposes and which must be sited on the runway strip, and satisfying the relevant frangibility requirement, shall be permitted on any part of a runway strip of a precision approach runway delineated by the lower edges of the inner transitional surfaces; and, mobile objects shall not be permitted on this part of the runway strip during the use of the runway for landing or take-off.
- (9) That portion of a strip of an instrument runway within a distance of at least:
- (a) 75 m where the code number is 3 or 4; and
  - (b) 40 m where the code number is 1 or 2; from the center line of the runway and its extended center line shall provide a graded area for aero planes which the runway is intended to serve in the event of an aircraft running off the runway.
- (10) That portion of a strip of a non-instrument runway within a distance of at least;
- (a) 75 m where the code number is 3 or 4;
  - (b) 40 m where the code number is 2; and
  - (c) 30 m where the code number is 1; from the center line of the runway and its extended center line shall provide a graded area for aero planes which the runway is intended to serve in the event of an aero plane running off the runway.
- (11) The surface of that portion of a strip that abuts a runway, shoulder or stop way shall be flush with the surface of the runway, shoulder or stop way.

- (12) A blast pad that is a portion of a strip to at least 30 m before the start of a runway shall be prepared against blast erosion in order to protect a landing aeroplane from the danger of an exposed edge
- (13) Where the areas in sub-regulation (12) have paved surfaces, they shall be able to withstand the occasional passage of the critical aeroplane for runway pavement design.

#### **48. Slopes On Runway Strips**

- (1) A longitudinal slope along that portion of a strip to be graded shall not exceed
  - (a) 1.5 per cent where the code number is 4;
  - (b) 1.75 per cent where the code number is 3; and
  - (c) 2 per cent where the code number is 1 or 2.
- (2) Longitudinal slope changes on that portion of a strip to be graded shall be as gradual as practicable and abrupt changes or sudden reversals of slopes avoided.
- (3) Transverse slopes on that portion of a strip to be graded shall be adequate to prevent the accumulation of water on the surface but shall not exceed:
  - (a) 2.5 per cent where the code number is 3 or 4; and
  - (b) 3 per cent where the code number is 1 or 2;
- (4) except that to facilitate drainage the slope for the first 3 m outward from the runway, shoulder and stop way edge shall be negative as measured in the direction away from the runway and may be as great as 5 per cent.
- (5) The transverse slopes of any portion of a strip beyond that to be graded shall not exceed an upward slope of 5 per cent as measured in the direction away from the runway.
- (6) Where deemed necessary for proper drainage, an open-air storm water conveyance may be allowed in the non-graded portion of a runway strip and shall be placed as far as practicable from the runway.
- (7) Where an open-air storm water conveyance is located within the non-graded portion of a runway strip, the aerodrome RFF procedure shall take into account the location of open-air water conveyances.
- (8) The strength of that portion of a strip of an instrument runway within a distance of at least:
  - (a) 75 m where the code number is 3 or 4; and
  - (b) 40 m where the code number is 1 or 2;
- (9) From the centre line of runway and its extended centre line shall be so prepared or constructed as to minimize hazards arising from differences in load-bearing capacity to aeroplanes which the runway is intended to serve in the event of an aeroplane running off the runway.
- (10) The strength of that portion of a strip containing a non-instrument runway within a distance of at least:
  - (a) 75 m where the code number is 3 or 4;
  - (b) 40 m where the code number is 2; and
  - (c) 30 m where the code number is 1;

- (11) From the centre line of the runway and its extended centre line shall be so prepared or constructed as to minimize hazards arising from differences in load-bearing capacity to aeroplanes which the runway is intended to serve in the event of an aeroplane running off the runway.

#### **49. Runway End Safety Area**

- (1) An aerodrome operator shall provide a runway end safety area at each end of a runway strip where:
  - (a) the code number is 3 or 4; and
  - (b) the code number is 1 or 2 and the runway is an instrument one.
- (2) A runway end safety area shall be provided at each end of a runway strip where the code number is 1 or 2 and the runway is a non-instrument one.
- (3) A runway end safety area shall extend from the end of a runway strip to a distance of at least:
  - (a) 240 m where the code number is 3 or 4; or a reduced length when an arresting system is installed;
  - (b) 120 m where the code number is 1 or 2 and the runway is an instrument one; or a reduced length when an arresting system is installed; and
  - (c) 30 m where the code number is 1 or 2 and the runway is a non-instrument one.
- (4) Where compliance with sub regulation (3) is not practicable, a runway end safety area shall extend from the end of a runway strip to a distance of at least 90 m where:
  - (a) the code number is 3 or 4; and
  - (b) the code number is 1 or 2 and the runway is an instrument one
- (5) The width of a runway end safety area shall be at least twice that of the associated runway or wherever practicable, be equal to that of the graded portion of the associated runway strip.
- (6) An object situated on a runway end safety area which may endanger aeroplanes shall be regarded as an obstacle and shall, as far as practicable, be removed.
- (7) A runway end safety area shall provide a cleared and graded area for aeroplanes which the runway is intended to serve in the event of an aeroplane undershooting or overrunning the runway.
- (8) The slopes of a runway end safety area shall be such that no part of the runway end safety area penetrates the approach or take-off climb surface.
- (9) The longitudinal slopes of a runway end safety area shall not exceed a downward slope of 5 percent and longitudinal slope changes shall be as gradual as practicable with abrupt changes or sudden reversals of slopes avoided.
- (10) The transverse slopes of a runway end safety area shall not exceed an upward or downward slope of 5 per cent.
- (11) Transitions between differing slopes shall be as gradual as practicable.

- (12) A runway end safety area shall be so prepared or constructed as to reduce the risk of damage to an aeroplane undershooting or overrunning the runway, enhance aeroplane deceleration and facilitate the movement of rescue and fire fighting vehicles.

## **50. Clearways**

- (1) The origin of a clearway where provided, shall be at the end of the take-off run available.
- (2) The length of a clearway shall not exceed half the length of the take-off run available.
- (3) A clearway shall extend laterally on each side of the extended centre line of the runway, to a distance of at least:
  - (a) 75 m for instrument runways; and
  - (b) half of the width of the runway strip for non-instrument runways.
- (4) The ground in a clearway shall not project above a plane having an upward slope of 1.25 per cent, the lower limit of this plane being a horizontal line which:
  - (a) is perpendicular to the vertical plane containing the runway center line; and
  - (b) passes through a point located on the runway center line at the end of the take-off run available.
- (5) Abrupt upward changes in slope shall be avoided when the slope on the ground in a clearway is relatively small or when the mean slope is upward
- (6) Subject to sub-regulation (5), the portion of the clearway within a distance of 22.5 m or half the runway width, whichever is greater, on each side of the extended centre line, the slopes, slope changes and the transition from runway to clearway shall conform with those of the runway with the clearway is associated.
- (7) An object situated on a clearway which may endanger aeroplanes in the air shall be regarded as an obstacle and shall be removed.

## **51. Stop Ways**

- (1) A stop way shall have the same width as the runway with which it is associated.
- (2) Slopes and changes in slope on a stop way, and the transition from a runway to a stop way, shall comply with the requirements of regulation 4 for the runway with which the stop way is associated except that:
  - (a) the limitation in regulation 43 of a 0.8 per cent slope for the first and last quarter of the length of a runway need not be applied to the stop way; and
  - (b) at the junction of the stop way and runway and along the stop way the maximum rate of slope change may be 0.3 percent per 30 m (minimum radius of curvature of 10 000 m) for a runway where the code number is 3 or 4.
- (3) A stop way shall be prepared or constructed to achieve strength so as to be capable, in the event of an abandoned take-off, of supporting the aircraft which the stop way is intended to serve without inducing structural damage to the aircraft.
- (4) The surface of a paved stop way shall be so constructed or resurfaced as to provide surface friction characteristics at or above those of the associated runway.

**52. Radio Altimeter Operating Area**

- (1) An aerodrome operator shall establish a radio altimeter operating area in the pre-threshold area of a precision approach runway.
- (2) The length of a radio altimeter operating area shall extend before the threshold for a distance of at least 300 m.
- (3) The width of a radio altimeter operating area shall extend laterally, on each side of the extended centre line of the runway, to a distance of 60 m, except that, when special circumstances so warrant, the distance may be reduced to no less than 30 m where an aeronautical study indicates that such reduction shall not affect the safety of operations of aircraft.
- (4) Longitudinal slope changes on a radio altimeter operating area shall be avoided or kept to a minimum and where slope changes cannot be avoided, abrupt changes or sudden reversals of slopes shall be avoided and shall be as gradual as practicable and the rate of change between two consecutive slopes shall not exceed 2 percent per 30 m.

**53. Taxiways**

- (1) An aerodrome operator shall provide taxiways to permit the safe and expeditious surface movement of aircraft.
- (2) Sufficient entrance and exit taxiways for a runway shall be provided to expedite the movement of aero planes to and from the runway and provision of rapid exit taxiways considered when traffic volumes are high.
- (3) The design of a taxiway shall be such that, when the cockpit of the aircraft for which the taxiway is intended remains over the taxiway center line markings, the clearance distance between the outer main wheel of the aircraft and the edge of the taxiway shall not be less than that given by the following tabulation:

OMGWS

Up to but not including 4.5	4.5 m up to but not including 6 m	6 m up to but not including 9 m	9 m up to but not including 15 m
--------------------------------------	--	---------------------------------------	---

<sup>a</sup> on straight portions.

<sup>b</sup> on curved portions where the taxiway is intended to be used by aeroplanes with a wheelbase of less than 18 m.

<sup>c</sup> on curved portions where the taxiway is intended to be used by aeroplanes with a wheel base equal to or greater than 18 m

- (4) A straight portion of a taxiway shall have a width of not less than that given by the following tabulation:

OMGWS

Clearance	Up to but not including 4.5	4.5 m up to but not including 6 m	6 m up to but not including 9 m	9 m up to but not including 15 m
Taxiway width	7.5 m	10.5 m	15 m	23 m

- (5) An operator shall ensure that:
- (a) Changes in direction of taxiways shall be as few and small as possible;
  - (b) The radii of the curves shall be compatible with the manoeuvring capability and normal taxiing speeds of the aircraft for which the taxiway is intended;
  - (c) The design of the curve shall be such that, when the cockpit of the aircraft remains over the taxiway center line markings, the clearance distance between the outer main wheels of the aircraft and the edge of the taxiway shall not be less than those specified in sub-regulation (3).

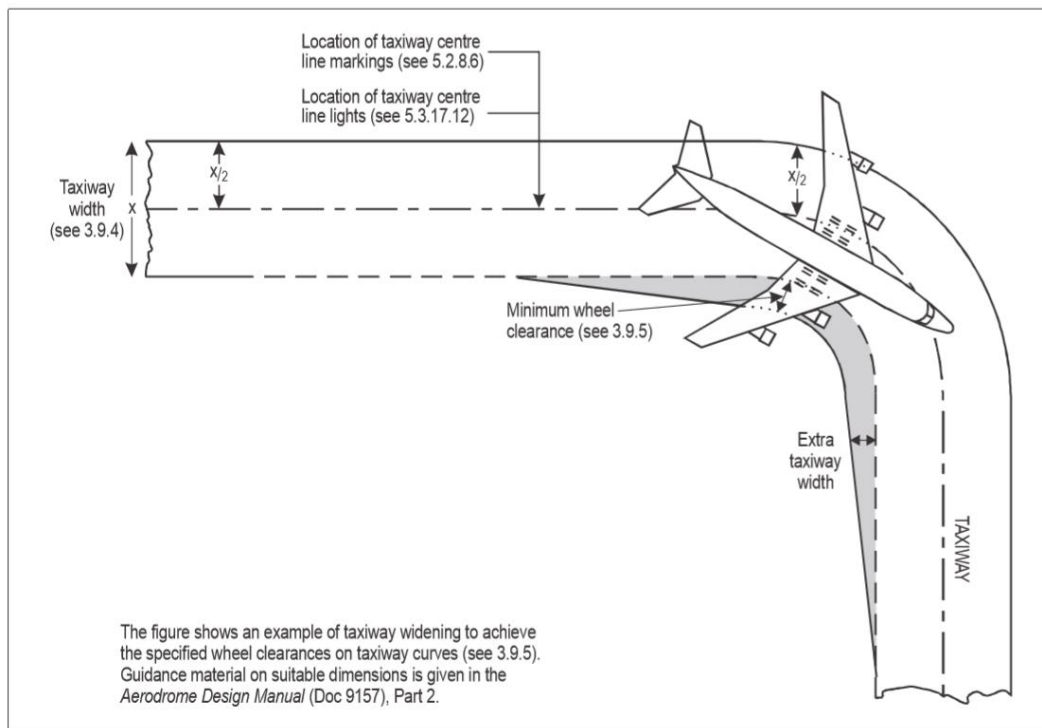

**Taxiway Curve**

- (5) To facilitate the movement of aero planes, fillets shall be provided at junctions and intersections of taxiways with runways, aprons and other taxiways.
- (6) The design of the fillets shall ensure that the minimum wheel clearances specified in sub-regulation (3) are maintained when aero planes are maneuvering through the

junctions or intersections; and consideration shall be given to the aero plane datum length when designing fillets.

- (7) The separation distance between the center line of a taxiway and the center line of a runway, the center line of a parallel taxiway or an object shall not be less than the appropriate dimension specified in Table 2, except that it may be permissible to operate with lower separation distances at an existing aerodrome where an aeronautical study indicates that such lower separation distances shall not adversely affect the safety or significantly affect the regularity of operations of aero planes.
- (8) The longitudinal slope of a taxiway shall not exceed:
- (a) 1.5 per cent where the code letter is C, D, E or F; and
  - (b) 3 per cent where the code letter is A or B.
- (9) Where slope changes on a taxiway cannot be avoided, the transition from one slope to another slope shall be accomplished by a curved surface with a rate of change not exceeding:
- (a) 1 per cent per 30 m (minimum radius of curvature of 3 000 m) where the code letter is C, D, E or F; and
  - (b) 1 per cent per 25 m (minimum radius of curvature of 2 500 m) where the code letter is A or B.

**Table 2. Taxiway Minimum Separation Distances**

Distance between taxiway center line and runway center line (meters)											
Code letter	Instrument				Non-instrument runways code number				Taxiway centreline to taxiway centre line (metres)	Taxiway, other than aircraft stand taxiway, centre line to object (metres)	Aircraft stand taxiway centre line to aircraft stand taxiway centre line (metres)
	1	2	3	4	1	2	3	4			
(1)	(2)	(3)	(4)	(5)	(6)	(7)	(8)	(9)	(10)	(11)	(12)
A	77.5	77.5	-	-	37.5	47.5	-	-	23	15.5	19.5
B	82	82	152	-	42	52	87	-	32	20	28.5
C	88	88	158	158	48	58	93	93	44	26	40.5
D	-	-	166	166	-	-	101	101	63	37	59.5
E	-	-	172.5	172.5	-	-	107.5	107.5	76	43.5	72.5
F	-	-	180	180	-	-	115	115	91	51	87.5

- (10) Where a change in slope on a taxiway cannot be avoided, the change shall be such that, from any point:
- (a) 3 m above the taxiway, it shall be possible to see the whole surface of the taxiway for a distance of at least 300 m from that point, where the code letter is C, D, E or F;
  - (b) 2 m above the taxiway, it shall be possible to see the whole surface of the taxiway for a distance of at least 200 m from that point, where the code letter is B; and
  - (c) 1.5 m above the taxiway, it shall be possible to see the whole surface of the taxiway for a distance of at least 150 m from that point, where the code letter is A.
- (11) The transverse slopes of a taxiway shall be sufficient to prevent the accumulation of water on the surface of the taxiway but shall not exceed:
- i. 1.5 per cent where the code letter is C, D, E or F; and
  - ii. 2 per cent where the code letter is A or B.
- (12) The strength of a taxiway shall be at least equal to that of the runway it serves, due consideration being given to the fact that a taxiway shall be subjected to a greater density of traffic and, as a result of slow moving and stationary aeroplanes, to higher stresses than the runway it serves.
- (13) The surface of a taxiway shall not have irregularities that cause damage to aeroplane structures.
- (14) The surface of a paved taxiway shall be so constructed or resurfaced as to provide suitable surface friction characteristics.
- (15) For the purpose of sub-regulation (15) Suitable surface friction characteristics are those surface properties required on taxiways that assure safe operation of aeroplanes.

#### **54. Rapid Exit Taxiways**

- (1) A rapid exit taxiway as illustrated in the figure below shall be designed with a radius of turn-off curve of at least:
- (a) 550 m where the code number is 3 or 4; and
  - (b) 275 m where the code number is 1 or 2;
- to enable exit speeds under wet conditions of:
- (a) 93 km/h where the code number is 3 or 4; and
  - (b) 65 km/h where the code number is 1 or 2.
- (2) The radius of the fillet on the inside of the curve at a rapid exit taxiway shall be sufficient to provide a widened taxiway throat in order to facilitate early recognition of the entrance and turn-off onto the taxiway.
- (3) A rapid exit taxiway shall include a straight distance after the turn-off curve sufficient for an existing aircraft to come to a full stop clear of any intersecting taxiway.

- (4) The intersection angle of a rapid exit taxiway with the runway shall not be greater than  $45^\circ$  nor less than  $25^\circ$  and preferably shall be  $30^\circ$ .

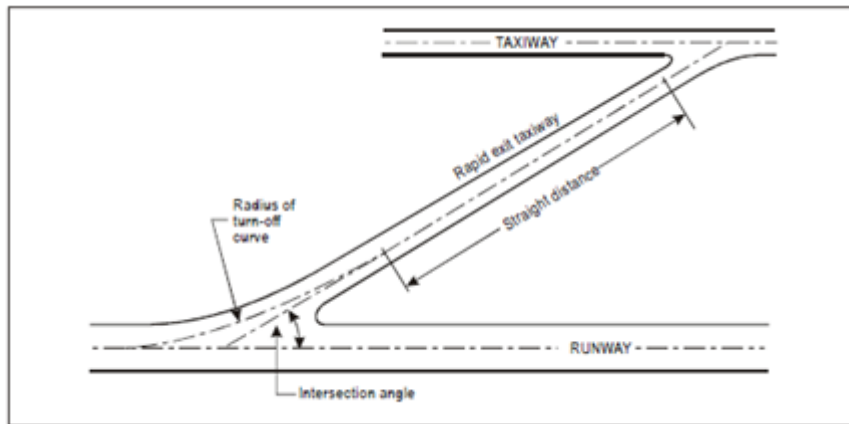

**Rapid Exit Taxiway**

### **55. Taxiways On Bridges**

- (1) The width of that portion of a taxiway bridge capable of supporting aeroplanes, as measured perpendicularly to the taxiway centre line, shall not be less than the width of the graded area of the strip provided for that taxiway, unless a proven method of lateral restraint is provided which shall not be hazardous for aeroplanes for which the taxiway is intended.
- (2) Access shall be provided to allow rescue and fire fighting vehicles to intervene in both directions within the specified response time to the largest aeroplane for which the taxiway bridge is intended.
- (3) A bridge shall be constructed on a straight section of the taxiway with a straight section on both ends of the bridge to facilitate the alignment of aeroplanes approaching the bridge.

### **56. Taxiway Shoulders**

- (1) Straight portions of a taxiway where the code letter is C, D, E or F shall be provided with shoulders which extend symmetrically on each side of the taxiway so that the overall width of the taxiway and its shoulders on straight portions is not less than:
  - (a) 44 m where the code letter is F;
  - (b) 38 m where the code letter is E;
  - (c) 34 m where the code letter is D; and
  - (d) 25 m where the code letter is C.
- (2) Subject to sub-regulation (1) where increased pavement is provided on taxiway curves and on junctions or intersections, the shoulder width shall be not less than that on the adjacent straight portions of the taxiway.

- (3) When a taxiway is intended to be used by turbine-engine aeroplanes, the surface of the taxiway shoulder shall be so prepared as to resist erosion and the ingestion of the surface material by aeroplane engines.

## **57. Taxiway Strips**

- (1) A taxiway, other than an aircraft stand taxi lane, shall be included in a strip.
- (2) A taxiway strip shall extend symmetrically on each side of the center line of the taxiway throughout the length of the taxiway to at least the distance from the center line given in Table 2, column 11.
- (3) An operator shall ensure that the taxiway strip provides an area clear of objects which may endanger taxiing aeroplanes and:
  - (a) Give consideration to the location and design of drains on a taxiway strip to prevent damage to an aeroplane accidentally running off a taxiway;
  - (b) Where open-air or covered storm water conveyances are installed, consideration shall have to be given to ensure that their structure do not extend above the surrounding ground so as not to be considered an obstacle; and
  - (c) Particular attention needs to be given to the design and maintenance of an open-air storm water conveyance in order to prevent wildlife attraction, notably birds.
- (4) The center portion of a taxiway strip shall provide a graded area to a distance from the center line of the taxiway of not less than that given by the following tabulation:
  - (a) 10.25 m where the OMGWS is up to but not including 4.5 m
  - (b) 11 m where the OMGWS is 4.5 m up to but not including 6 m
  - (c) 12.50 m where the OMGWS is 6 m up to but not including 9 m
  - (d) 18.50 m where the OMGWS is 9 m up to but not including 15 m, where the code letter is D
  - (e) 19 m where the OMGWS is 9 m up to but not including 15 m, where the code letter is E
  - (f) 22 m where the OMGWS is 9 m up to but not including 15 m, where the code letter is
- (5) The surface of the strip shall be flush at the edge of the taxiway or shoulder, where provided, and the graded portion shall not have an upward transverse slope exceeding:
  - (a) 2.5 per cent for strips where the code letter is C, D, E or F; and
  - (b) 3 per cent for strips of taxiways where the code letter is A or B.
- (6) Subject to sub-regulation (5) the upward slope shall be measured with reference to the transverse slope of the adjacent taxiway surface and not the horizontal and the downward transverse slope shall not exceed 5 per cent measured with reference to the horizontal.
- (7) The transverse slopes on any portion of a taxiway strip beyond that to be graded shall not exceed an upward or downward slope of 5 per cent as measured in the direction away from the taxiway.

- (8) Where deemed necessary for proper drainage, an open-air storm water conveyance may be allowed in the non-graded portion of a taxiway strip and shall be placed as far as practicable from the taxiway.
- (9) The aerodrome RFF procedure shall take into account the location of open-air storm water conveyances within the non-graded portion of a taxiway strip.

**58. Holding Bays, Runway Holding Positions, Intermediate Holding Positions and Road Holding Positions**

- (1) An aerodrome operator shall provide holding bay(s) at aerodromes where the traffic density is medium or heavy.
- (2) The operator shall establish a runway-holding position or positions
  - (a) on the taxiway, at the intersection of a taxiway and a runway; and
  - (b) at an intersection of a runway with another runway when the former runway is part of a standard taxi-route.
- (3) The operator shall establish a runway-holding position on a taxiway where the location or alignment of the taxiway is such that a taxiing aircraft or vehicle can infringe an obstacle limitation surface or interfere with the operation of radio navigation aids.
- (4) The operator shall establish an intermediate holding position on a taxiway at any point other than a runway-holding position where it is desirable to define a specific holding limit.
- (5) The operator shall establish a road-holding position at an intersection of a road with a runway.
- (6) The distance between a holding bay, runway-holding position established at a taxiway/runway intersection or road-holding position and the center line of a runway shall be in accordance with Table 3 and, in the case of a precision approach runway, such that a holding aircraft or vehicle shall not interfere with the operation of radio navigation aids or penetrate the inner transitional surface.
- (7) At elevations greater than 700 m (2300 ft) the distance of 90 m specified in Table 3 for a precision approach runway code number 4 shall be increased as follows:
  - (a) up to an elevation of 2000 m (6600 ft); 1 m for every 100 m (330 ft) in excess of 700 m (2300 ft);
  - (b) elevation in excess of 2 000 m (6600 ft) and up to 4000 m (13320 ft); 13 m plus 1.5 m for every 100 m (330 ft) in excess of 2000 m (6 600 ft); and
  - (c) elevation in excess of 4000 m (13320 ft) and up to 5000 m (16 650 ft); 43 m plus 2 m for every 100 m (330 ft) in excess of 4000 m (13320 ft).
- (8) Where a holding bay, runway-holding position or road-holding position for a precision approach runway code number 4 is at a greater elevation compared to the threshold, the distance specified in Table 3 shall be further increased 5 m for every meter the bay or position is higher than the threshold.
- (9) The location of a runway-holding position established in accordance with sub-regulation (3) shall be such that a holding aircraft or vehicle shall not infringe the

obstacle free zone, approach surface, take-off climb surface or ILS/MLS critical/sensitive area or interfere with the operation of radio navigation aids.

**Table 3. Minimum distance from the runway center line to a holding bay, runway-holding position or road-holding position**

Type of Runway	Code Number			
	1	2	3	4
Non-instrument	30 m	40 m	75 m	75 m
Non-precision approach	40 m	40 m	75 m	75 m
Precision approach category I	60 m <sup>b</sup>	60 m <sup>b</sup>	90 m <sup>a,b</sup>	90 m <sup>a,b</sup>
Precision approach category II and III	-	-	90 m <sup>a,b</sup>	90 m <sup>a,b</sup>
Take-off runway	30 m	40 m	75 m	75 m

- (a) Where a holding bay, runway-holding position or road-holding position is at a lower elevation compared to the threshold, the distance of 90 m in columns 3 and 4 may be decreased 5 m for every meter the bay or holding position is lower than the threshold, contingent upon not infringing the inner transitional surface.
- (b) The distance of 60 m and 90 m in columns 1, 2, 3 and 4 may need to be increased to avoid interference with radio navigation aids, particularly the glide path and localizer facilities.

- (10) Where a holding bay, runway-holding position or road-holding position for a precision approach runway code number 4 is at a greater elevation compared to the threshold; the distance specified in Table 3 shall be further increased 5 m for every meter the bay or position is higher than the threshold.

## 59. Aprons

- (1) An aerodrome operator shall provide an apron where necessary to permit the on- and off-loading of passengers, cargo or mail as well as the servicing of aircraft without interfering with the aerodrome traffic.
- (2) Where an apron is provided, the total apron area shall be adequate to permit expeditious handling of the aerodrome traffic at its maximum anticipated density.
- (3) Each part of an apron shall be capable of withstanding the traffic of the aircraft it is intended to serve, due consideration being given to the fact that some portions of the

apron shall be subjected to a higher density of traffic and, as a result of slow moving or stationary aircraft, to higher stresses than a runway.

- (4) Slopes on an apron, including those on an aircraft stand taxilane, shall be sufficient to prevent accumulation of water on the surface of the apron but shall be kept as level as drainage requirements permit.
- (5) On an aircraft stand, where applicable, the maximum slope shall not exceed 1 per cent.
- (6) An aircraft stand shall provide the following minimum clearances between an aircraft entering or exiting the stand and any adjacent building, aircraft on another stand and other objects:

Code letter	Clearance
A	3 m
B	3 m
C	4.5 m
D	7.5 m
E	7.5 m
F	7.5 m

- (7) When special circumstances so warrant, these clearances may be reduced at a nose-in aircraft stand, where the code letter is D, E or F:
  - (a) between the terminal, including any fixed passenger bridge, and the nose of an aircraft;
  - (b) over any portion of the stand provided with azimuth guidance by a visual docking guidance system; and
  - (c) On aprons, consideration shall also be given to the provision of service roads and to maneuvering and storage area for ground equipment.

#### **60. Isolated Aircraft Parking Position**

- (1) An aerodrome operator shall designate an isolated aircraft parking position s and advise the aerodrome control tower of an area or areas suitable for the parking of an aircraft which is known or believed to be the subject of unlawful interference, or which for other reasons needs isolation from normal aerodrome activities.
- (2) The isolated aircraft parking position referred to in sub-regulation (1) shall be located at the maximum distance practicable and in any case not less than 100 m from other parking positions, buildings or public areas, among others.
- (3) The Aerodrome operator shall ensure that, an isolated aircraft parking position is not located over underground utilities such as gas and aviation fuel and, to the extent feasible, electrical or communication cables.

### **CHAPTER VI OBSTACLE RESTRICTION AND REMOVAL**

#### **61. Establishment of Obstacle Limitation Surfaces**

- (1) An aerodrome operator shall ensure that obstacle limitation surfaces are established for the aerodrome in accordance with this regulation.

- (2) An operator shall monitor the established obstacle limitation surfaces around the aerodrome for infringement by objects, buildings or other structures.
- (3) An aerodrome operator shall establish a systematic means of surveying and monitoring any object that penetrates obstacle limitation surfaces around the aerodrome and report any penetration immediately to the Authority.
- (4) An aerodrome operator shall notify through the Aeronautical Information Services any object that penetrates obstacle limitation surfaces around the aerodrome.
- (5) The operator of an aerodrome shall work jointly with the appropriate Authority to plan and determine the allowable height limits for new developments in the vicinity of and outside its aerodrome and the type of instrument or visual flight operations that may be permitted taking the obstacle survey plan into account.

## **62. Obstacle Limitation Surfaces**

The obstacle limitation surfaces shall comprise the following surfaces as shown in the figures 4-1 and 4-2 below:

- (a) Conical surface;
- (b) Inner horizontal surface;
- (c) Approach surface;
- (d) Inner approach surface;
- (e) Transitional surface;
- (f) Inner transitional surface; and
- (g) Balked landing surface.

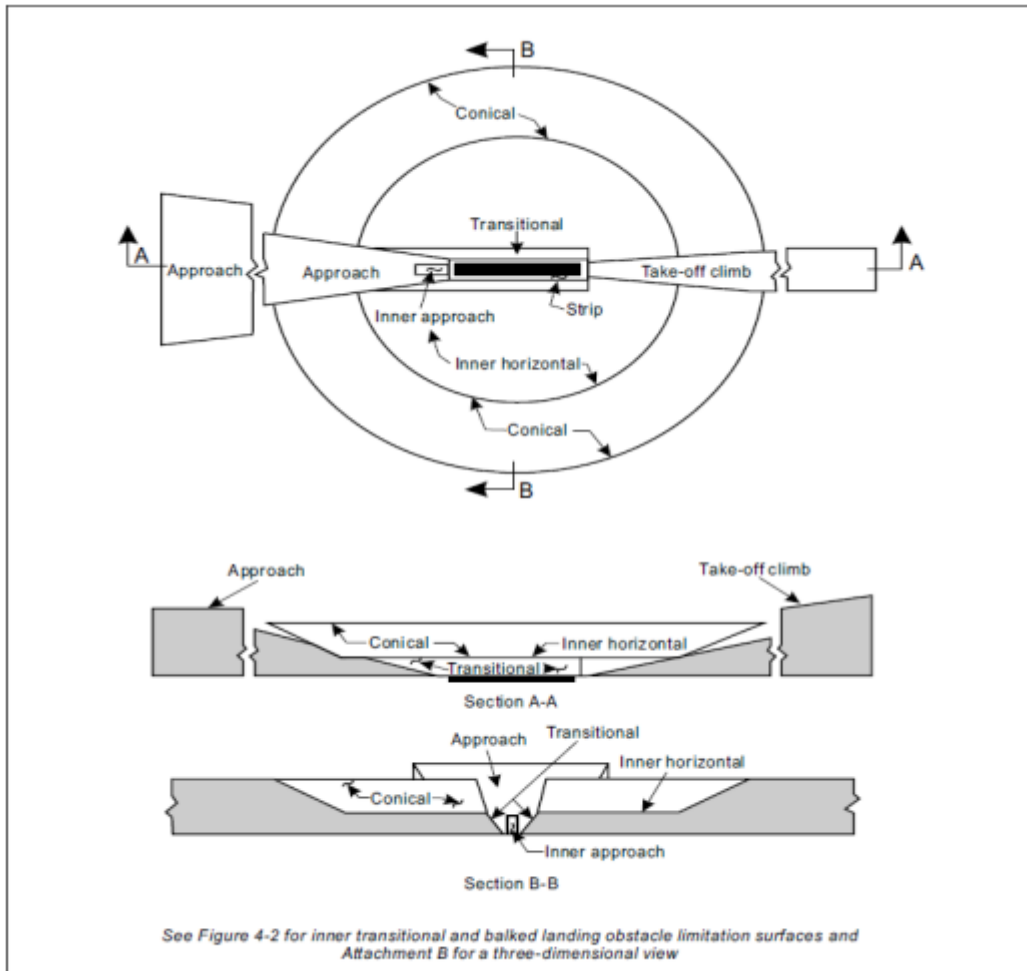

Figure 4-1. Obstacle limitation surfaces

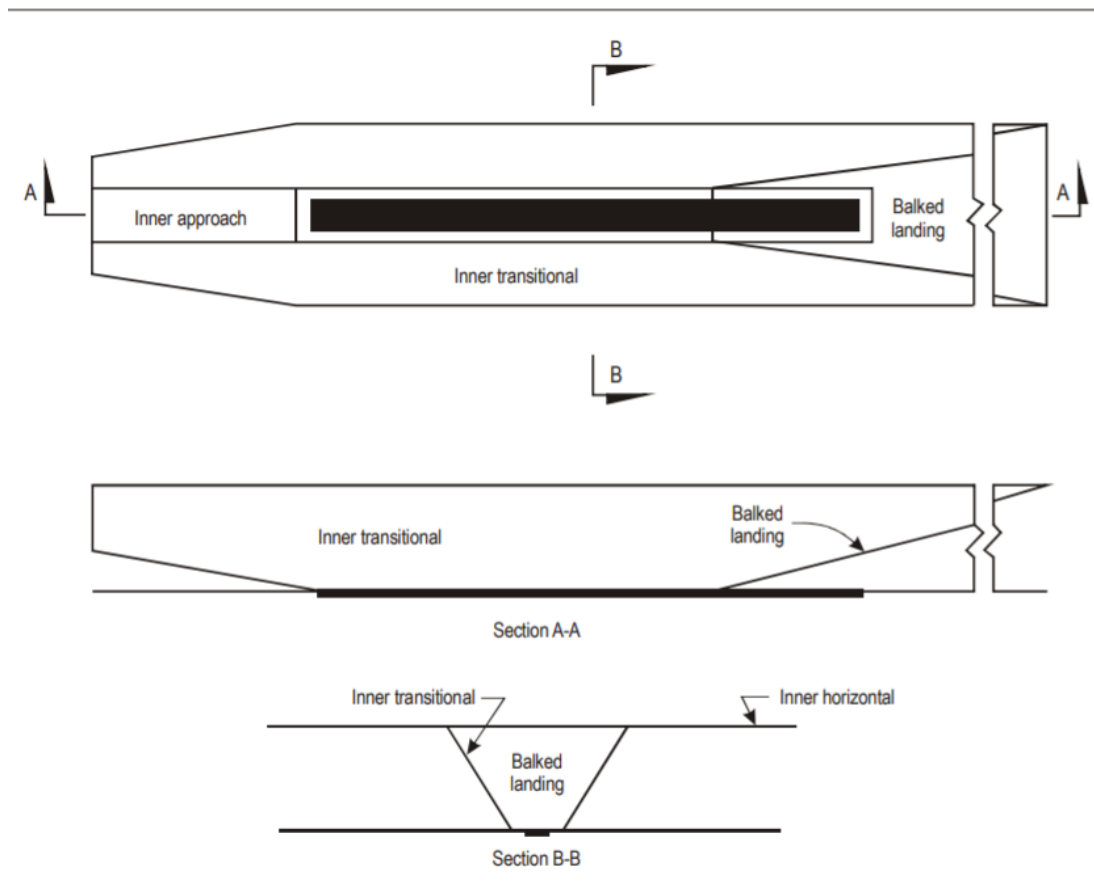

Figure 4-2 Inner approach, inner transitional and balked landing obstacle limitation surfaces

### 63. Outer Horizontal Surface

- (1) An outer horizontal surface is a horizontal plane around an aerodrome beyond the limits of the conical surface.
- (2) Subject to sub-regulation (1) the outer horizontal surface shall represent the level above which consideration needs to be given to the control of new obstacles in order to facilitate practicable and efficient instrument approach procedures, and together with the conical and inner horizontal surfaces to ensure safe visual manoeuvring in the vicinity of an aerodrome.
- (3) An outer horizontal surface is established for every aerodrome where the aerodrome reference code is 3 or 4.
- (4) For aerodrome reference code 3 or 4, the outer horizontal surface extends from the outer and upper periphery of the conical surface to a minimum radius of 15 000 m from the aerodrome reference point.
- (5) The outer horizontal surface level shall be up to 150 m height above aerodrome elevation.

### 64. Conical Surface

- (1) A conical surface is a surface sloping upwards and outwards from the periphery of the inner horizontal surface:
  - (a) a lower edge coincident with the periphery of the inner horizontal surface; and
  - (b) an upper edge located at a specified height above the inner horizontal surface.

- (3) The slope of the conical surface shall be measured in a vertical plane perpendicular to the periphery of the inner horizontal surface.

**65. Inner Horizontal Surface**

- (1) The Inner horizontal surface is a surface located in a horizontal plane above an aerodrome and its environs.
- (2) The radius or outer limits of the inner horizontal surface shall be measured from a reference point or points established for such purpose.
- (3) The height of the inner horizontal surface shall be measured above an elevation datum established for such purpose.

**66. Approach Surface**

- (1) The approach surface is an inclined plane or combination of planes preceding the threshold.
- (2) The limits of the approach surface shall comprise the following characteristics:
  - (a) an inner edge of specified length, horizontal and perpendicular to the extended center line of the runway and located at a specified distance before the threshold;
  - (b) two sides originating at the ends of the inner edge and diverging uniformly at a specified rate from the extended center line of the runway;
  - (c) an outer edge parallel to the inner edge; and
  - (d) the above surfaces shall be varied when lateral offset, offset or curved approaches are utilized, specifically, two sides originating at the ends of the inner edge and diverging uniformly at a specified rate from the extended center line of the lateral offset, offset or curved ground track.
- (3) The elevation of the inner edge shall be equal to the elevation of the mid-point of the threshold.
- (4) The slope(s) of the approach surface shall be measured in the vertical plane containing the center line of the runway and shall contain the center line of any lateral offset or curved ground track.

**67. Inner Approach Surface**

- (1) The Inner approach surface is a rectangular portion of the approach surface immediately preceding the threshold.
- (2) The limits of the inner approach surface shall comprise the following characteristics:
  - (a) an inner edge coincident with the location of the inner edge of the approach surface but of its own specified length;
  - (b) two sides originating at the ends of the inner edge and extending parallel to the vertical plane containing the center line of the runway; and
  - (c) an outer edge parallel to the inner edge.

**68. Transitional Surface**

- (1) The Transitional surface is a complex surface along the side of the strip and part of the side of the approach surface, the slopes upwards and outwards to the inner horizontal surface.
- (2) The limits of the transitional surface shall comprise the following characteristics:

- (a) a lower edge beginning at the intersection of the side of the approach surface with the inner horizontal surface and extending down the side of the approach surface to the inner edge of the approach surface and from there along the length of the strip parallel to the runway center line; and
  - (b) an upper edge located in the plane in the inner horizontal surface.
- (3) The elevation of a point on the lower edge shall be:
- (a) along the side of the approach surface – equal to the elevation of the approach surface at that point; and
  - (b) along the strip – equal to the elevation of the nearest point on the center line of the runway or its extension.
- (4) Pursuant to sub-regulation (3) (b) the transitional surface along the strip shall be curved where the runway profile is curved, or a plane where the runway profile is a straight line; the intersection of the transitional surface with the inner horizontal surface shall also be a curved or a straight line depending on the runway profile.
- (5) The slope of the transitional surface shall be measured in a vertical plane at right angles to the center line of the runway.

**69. Inner Transitional Surface**

- (1) The inner transitional surface shall be the controlling obstacle limitation surface for navigation aids, aircraft, buildings and vehicles that must be near the runway and shall not to be penetrated except for frangible objects.
- (2) The Inner transitional surface is a surface similar to the transitional surface but closer to the runway.
- (3) The limits of an inner transitional surface shall comprise:
- (a) a lower edge beginning at the end of the inner approach surface and extending down the side of the inner approach surface to the inner edge of that surface, from there along the strip parallel to the runway centre line to the inner edge of the balked landing surface and from there up the side of the balked landing surface to the point where the side intersects the inner horizontal surface; and
  - (b) an upper edge located in the plane of the inner horizontal surface.
- (4) The elevation of a point on the lower edge shall be:
- (a) along the side of the inner approach surface and balked landing surface – equal to the elevation of the particular surface at that point; and
  - (b) along the strip – equal to the elevation of the nearest point on the centre line of the runway or its extension.
- (5) Pursuant to sub-regulation (2) (b) the inner transitional surface along the strip shall be curved where the runway profile is curved or a plane where the runway profile is a straight line; the intersection of the inner transitional surface with the inner horizontal surface shall also be a curved or a straight line depending on the runway profile.
- (6) The slope of inner transitional surface shall be measured in a vertical plane at right angles to the center line of the runway.

**70. Balked Landing Surface**

- (1) A Balked landing surface is an inclined plane located at a specified distance after the threshold, extending between the inner transitional surfaces.
- (2) The limits of the balked landing surface shall comprise the following characteristics:

- (a) an inner edge horizontal and perpendicular to the centre line of the runway and location at a specified distance after the threshold;
  - (b) two sides originating at the ends of the inner edge and diverging uniformly at a specified rate from the vertical plane containing the centre line of the runway; and
  - (c) an outer edge parallel to the inner edge and located in the plane of the inner horizontal surface.
- (3) The elevation of the inner edge shall be equal to the elevation of the runway center line at the location of the inner edge.
  - (4) The slope of the balked landing surface shall be measured in the vertical plane containing the center line of the runway.

#### **71. Take-Off Climb Surface**

- (1) The take-off climb surface is an inclined plane or other specified surface beyond the end of a runway or clearway.
- (2) The limits of the take-off climb surface shall comprise the following characteristics -
  - (a) an inner edge horizontal and perpendicular to the centre line of the runway and located either at a specified distance beyond the end of the runway or at the end of the clearway when such is provided, and its length exceeds the specified distance;
  - (b) two sides originating at the ends of the inner edge, diverging uniformly at a specified rate from the take-off track to a specified final width and continuing thereafter at that width for the remainder of the length of the take-off climb surface; and
  - (c) an outer edge horizontal and perpendicular to the specified take-off track.
- (3) The elevation of the inner edge shall be equal to the highest point on the runway center line between the end of the runway and the inner edge, except that when a clearway is provided the elevation shall be equal to the highest point on the ground on the center line of the clearway.
- (4) In the case of a straight take-off flight path, the slope of the take-off climb surface shall be measured in the vertical plane containing the center line of the runway.
- (5) In the case of a take-off flight path involving a turn, the take-off climb surface shall be a complex surface containing the horizontal normal to its center line, and the slope of the center line shall be the same as that for a straight take-off flight path.

#### **72. Obstacle Limitation Requirements for Non- Instrument Runways**

- (1) The aerodrome operator shall specify the requirements for obstacle limitation surfaces on the basis of the intended use of a runway, that is, take-off or landing and type of approach, and shall be applied when such use is made of the runway and in cases where operations are conducted to or from both directions of a runway.
- (2) Subject to sub-regulation (1) the function of certain surfaces may be nullified due to more stringent requirements of another lower surface in cases where operations are conducted to or from both directions of the runway.
- (3) The aerodrome operator shall establish the following obstacle limitation surfaces for a non- instrument runway:
  - (a) conical surface;
  - (b) inner horizontal surface;

- (c) approach surface;
  - (d) transitional surfaces; and
  - (e) outer horizontal surface, where the aerodrome reference codes are 3 or 4.
- (4) The heights and slopes of the surfaces shall not be greater than, and their other dimensions not less than, those specified in Table 4-1 under regulation 74(3).
  - (5) New objects or extensions of existing objects shall not be permitted above an approach or transitional surface except when the new object or extension shall be shielded by an existing immovable object.
  - (6) The circumstances under which the shielding principle may reasonably be applied are described in the Second Schedule to these regulations.
  - (7) New objects or extensions of existing objects shall not be permitted above the conical surface or inner horizontal surface except when in the opinion of the Authority, the object shall be shielded by an existing immovable object, or after aeronautical study it is determined that the object shall not adversely affect the safety or significantly affect the regularity of aeroplane operations.
  - (8) Existing objects above any of the surfaces required by Regulation 139(2) shall as far as practicable be removed except when, in the opinion of the Authority, the object is shielded by an existing immovable object, or after aeronautical study it is determined that the object shall not adversely affect the safety or significantly affect the regularity of operations of aeroplanes.
  - (9) Due to transverse or longitudinal slopes on a strip, in certain cases the inner edge or portions of the inner edge of the approach surface may be below the corresponding elevation of the strip.
  - (10) Subject to sub-regulation (9) the strip may not have to be graded to conform with the inner edge of the approach surface or the terrain or objects which are above the approach surface, and in addition, terrain or objects which are above the approach surface beyond the end of the strip, but below the level of the strip, may not have to be removed unless it is considered that they may endanger aeroplane.
  - (11) The aerodrome operator shall take into account the possible future development of an instrument runway and consequent requirement for more stringent obstacle limitation surfaces when considering proposed construction.

### **73. Obstacle Limitation Requirements for Non-Precision Approach Runway**

- (1) The aerodrome operator shall establish the following obstacle limitation surfaces for a non-precision approach runway:
  - (a) conical surface;
  - (b) inner horizontal surface;
  - (c) approach surface; and transitional surfaces.
- (2) The heights and slopes of the surfaces shall not be greater than, and their other dimensions not less than, those specified in Table 4-1 below, except in the case of the horizontal section of the approach surface as per Regulation 140(3).
- (3) The approach surface shall be horizontal beyond the point at which the 2.5 per cent slope intersects:
  - (a) a horizontal plane 150m above the threshold elevation; or
  - (b) the horizontal plane passing through the top of any object that governs the obstacle clearance altitude/height (OCA/H); whichever is the higher

**Table 4-1 – Dimensions and Slopes of Obstacle Limitation Surfaces**

**APPROACH RUNWAYS**

Surfaces and Dimensions <sup>a</sup>	RUNWAY CLASSIFICATION									
	Non-instrument				Non-precision approach			Precision approach		
								Category		
								I	II or III	
	Code number				Code number			Code number	Code number	
	1	2	3	4	1,2	3	4	1,2	3,4	3,4
(1)	(2)	(3)	(4)	(5)	(6)	(7)	(8)	(9)	(10)	(11)
<b>CONICAL</b>										
Slope	5%	5%	5%	5%	5%	5%	5%	5%	5%	5%
Height	35 m	55 m	75 m	100 m	60 m	75 m	100 m	60 m	100m	100 m
<b>INNER HORIZONTAL</b>										
Height	45 m	45 m	45 m	45 m	45 m	45 m	45 m	45 m	45 m	45 m
Radius	2 000 m	2 500 m	4000 m	4000 m	3500 M	4000 m	4000 m	3500 m	4000 M	4000 M
<b>INNER APPROACH</b>										
Width	-	-	-	-	-	-	-	90 m	120 m <sup>e</sup>	120 m <sup>e</sup>
Distance from Threshold	-	-	-	-	-	-	-	60 m	60 m	60 m
Length	-	-	-	-	-	-	-	900 m	900 M	900 M

Slope	-	-	-	-	-	-	-	2.5%	2%	2%
APPROACH										
Length of inner edge	60m	80m	150m	150 m	140m	280 m	280 m	140 m	280m	280m
Distance from threshold	30m	60m	60m	60m	60m	60m	60m	60m	60m	60m
Divergence (each side)	10%	10%	10%	15%	15%	15%	15%	15%	15%	15%
First section										
Length	1600 m	2500 m	3000 m	3000 m	2500 M	3000 m	3000 m	3000 m	3000 M	3000 M
Slope	5%	4%	3.33 %	2.5%	3.33 %	2%	2%	2.5%	2%	2%

- (c) All dimensions are measured horizontally unless specified otherwise;
  - (d) Variable length (See Regulation);
  - (e) Distance to the end of strip;
  - (f) Or end of runway whichever is less; and
  - (g) Where the code letter is F (Column (3) of Table 3-1 of this Regulation), the width is increased to 155 m., the width is increased to 140m except for those aerodromes that accommodate a code letter F aeroplane equipped with digital avionics that provide steering commands to maintain an-established track during the go-around manoeuvre;
- (4) New objects or extensions of existing objects above an approach surface within 3,000m of the inner edge or above a transitional surface except when, in the opinion of the authority, the new object or extension shall be shielded by an existing immovable object.
- (5) New objects or extensions of existing objects above the approach surface beyond 3 000m from the inner edge, the conical surface or inner horizontal surface except when, in the opinion of the authority, the object shall be shielded by an existing immovable object, or after aeronautical study it is determined that the object shall not adversely affect the safety of Aeroplan operations.
- (6) Existing objects above any of the surfaces required by Regulation 140(1) shall as far as practicable be removed except when, in the opinion of the authority, the object is shielded by an existing immovable object, or after aeronautical study it is determined

that the object shall not adversely affect the safety or significantly affect the regularity of aeroplane operations.

#### **74. Obstacle Limitation Requirements for Precision Approach Runways**

- (1) An aerodrome operator shall establish following obstacle limitation surfaces for a precision approach runway category I:
  - (a) conical surface;
  - (b) inner horizontal surface;
  - (c) approach surface; and
  - (d) transitional surfaces.
  - (e) inner approach surface;
  - (f) inner transitional surfaces; and
  - (g) balked landing surface.
- (2) An aerodrome operator shall establish the following obstacle limitation surfaces for a precision approach runway category II or III;
  - (a) conical surface;
  - (b) inner horizontal surface;
  - (c) approach surface and inner approach surface;
  - (d) transitional surfaces;
  - (e) inner transitional surfaces; and
  - (f) balked landing surface.
- (3) The heights and slopes of the surfaces shall not be greater than, and their other dimensions not less than, those specified in Table 4-1 of these Regulation, except in the case of the horizontal section of the approach surface as per sub regulation (4) below.
- (4) The approach surface shall be horizontal beyond the point at which the 2.5 per cent slope intersects:
  - (a) a horizontal plane 150m above the threshold elevation; or
  - (b) the horizontal plane passing through the top of any object that governs the obstacle clearance limit; whichever is the higher.
- (5) The aerodrome operator shall not permit fixed objects above the inner approach surface, the inner approach surface, the inner transitional surface or the balked landing surface, except for frangible objects which because of their function must be located on the strip.
- (6) The aerodrome operator shall not permit mobile objects above these surfaces during the use of the runway for landing.
- (7) The aerodrome operator shall not permit new objects or extensions of existing objects above an approach surface or a transitional surface except when, in the opinion of the Authority in the opinion of the Authority, the new object or extension shall be shielded by an existing immovable object.
- (8) New objects or extensions of existing objects above the conical surface and the inner horizontal surface except when, in the opinion of the authority, an object shall be shielded by an existing immovable object, or after aeronautical study it is determined that the object shall not adversely affect or significantly affect the regularity the safety of aeroplane operations.
- (9) Existing objects above an approach surface, a transitional surface, the conical surface and inner horizontal surface shall as far as practicable be removed except when in the

opinion of the authority, an object is shielded by an existing immovable object, or after aeronautical study it is determined that the object shall not adversely affect the safety or significantly affect the regularity of aeroplane operations.

**75. Obstacle Limitation Requirements for Runways Meant for Take-Off**

- (1) The aerodrome operator shall establish a take-off climb surface for a runway meant for take-off.
- (2) The dimension of the surface shall be not less than the dimensions specified in Table 4-2 of this Regulation, except that a lesser length may be adopted or the take-off climb surface where such lesser length shall be consistent with procedural measures adopted to govern the outward flight of aeroplanes.
- (3) The operational characteristics of aeroplanes for which the runway is intended is examined to see where it is desirable to reduce the slope specified in Table 4-2 of this Regulation when critical operating conditions are to be catered to.
- (4) Subject to sub-regulation (3) where the specified slope is reduced, corresponding adjustment in the length of take-off climb surface shall be made so as to provide protection to a height of 300m.
- (5) When local conditions differ widely from sea level standard atmospheric conditions, it may be advisable for the slope specified in Table 4-2 to be reduced.
- (6) The degree of this reduction shall depend on the divergence between local conditions and sea level standard atmospheric conditions, and on the performance characteristics and operational requirements of the aeroplanes for which the runway is intended.
- (7) The aerodrome operator shall not permit new objects or extensions of existing objects above a take-off climb surface except when, in the opinion of the Authority, the new object or extension shall be shielded by an existing immovable object.
- (8) Where no object reaches the 2 per cent (1:50) take-off climb surface, new objects shall be limited to preserve the existing obstacle free surface or a surface down to a slope of 1.6 per cent (1:62.5).
- (9) Existing objects that extend above a take-off climb surface shall as far as practicable be removed except when, in the opinion of the Authority, an object is shielded by an existing immovable object, or after aeronautical study it is determined that the object shall not adversely affect the safety or significantly affect the regularity of aeroplane operations.

Table 4-2 – Dimensions and slopes of obstacle limitation surfaces  
RUNWAYS MEANT FOR TAKE-OFF

Surface and dimensions <sup>a</sup>	Code number		
	1	2	3 or 4
(1)	(2)	(3)	(4)
TAKE-OFF CLIMB			
Length of inner edge	60 m	80 m	180 m
Distance from runway end <sup>b</sup>	30 m	60 m	60 m

Divergence (each side)	10 %	10%	12.5%
Final width	380 m	580 m	1 200 m 1800 m <sup>c</sup>
Length	1 600 m	2 500 m	15 000 m
Slope	5%	4%	2% <sup>d</sup>

- (a) All dimensions are measured horizontally unless specified otherwise.
  - (b) The take-off climb surface starts at the end of the clearway where the clearway length exceeds the specified distance.
  - (c) 1 800 m when intended track includes changes of heading greater than 15° for operations conducted in IMC, VMC by night.
  - (d) See Regulations 142(3) and 142(6) of this Regulation.
- (10) Due to transverse slopes on a strip, or clearway, in certain cases portions of the inner edge of the take-off climb surface may be below the corresponding elevation of the strip, or clearway.
- (11) The strip, or clearway may not have to be graded to conform with the inner edge of the take-off climb surface, and in addition, terrain or objects which are above the take-off climb surface beyond the end of the strip or clearway, but below the level of the strip or clearway, may not have to be removed unless it is considered that they may endanger aircraft.
- (12) The considerations in sub-regulation (11) shall apply at the junction of a clearway and strip where differences in transfer slopes exist.

#### **76. Objects Outside Obstacle Limitation Surfaces**

- (1) An aerodrome operator shall make arrangements to consult the Authority concerning proposed construction beyond the limits of the obstacle limitation surfaces that extend above a height established in regulation 143(2) in order to permit an aeronautical study of the effect of such construction on the operation of aeroplanes.
- (2) In areas beyond the limits of the obstacle limitation surfaces, at least those objects that extend to a height of 150 m or more above ground elevation shall be regarded as obstacles, unless a special aeronautical study indicate that they do not constitute a hazard to operations of aeroplanes.

#### **77. Other Objects**

- (1) The aerodrome operator shall ensure that, objects which do not project through the approach surface, but never the less adversely affect the optimum siting or performance of visual or non-visual aids, are as far as practicable removed.
- (2) Where in the opinion of the Authority after aeronautical study, anything which may endanger aeroplanes on the movement area or in the air within the limits of the inner horizontal and conical surfaces shall be regarded as an obstacle and shall be removed in so far as practicable.

- (3) In certain circumstances, objects that do not project above any of the surfaces enumerated in Regulations 62 to 70 may constitute a hazard to aeroplanes as, for example, where there are one or more isolated objects in the vicinity of an aerodrome.

## **CHAPTER VII VISUAL AIDS FOR NAVIGATION**

### **Indicators and Signalling Devices**

#### **78. Wind Direction Indicators**

- (1) An aerodrome operator shall provide and maintain at least one wind direction indicator for an aerodrome.
- (2) The wind direction indicator required under sub-regulation (1) shall be located so as to be visible to an aircraft in-flight or on the movement area and in such a way as to be free from the effects of air disturbances caused by nearby objects.
- (3) The wind direction indicator shall;
  - (a) be in the form of a truncated cone made of fabric and shall have a length of not less than 3.6 m and a diameter, at the larger end, of not less than 0.9 m;
  - (b) be constructed so that it gives a clear indication of the direction of the surface wind and a general indication of the wind speed;
  - (c) have a color or colours selected as to make the wind direction indicator clearly visible and understandable from a height of at least 300m, having regard to background; or
  - (d) use a single colour, preferably white or orange where practicable.
- (4) Subject to sub-regulation (3) where a combination of two colours is required to give adequate conspicuity against changing backgrounds, preferably be orange and white, red and white, or black and white, and shall be arranged in five alternate bands, the first and last bands being the darker colour.
- (5) The aerodrome operator shall ensure that, the location of at least one wind direction indicator is marked by a circular band 15 m in diameter and 1.2 m wide.
- (6) The band referred to in sub-regulation (5) shall be centred about the wind direction indicator support, in a colour chosen to give adequate conspicuity, preferably white.
- (7) The aerodrome operator shall ensure that, at least one wind indicator at an aerodrome intended for use at night is illuminated.

#### **79. Landing Direction Indicator**

- (1) An aerodrome operator shall provide a landing direction indicator located in a conspicuous place on the aerodrome
- (2) The landing direction indicator shall be in the form of a “T”.
- (3) The shape and minimum dimensions of a landing “T” shall be as shown in the Figure below.
- (4) The colour of the landing “T” shall be either white or orange, the choice being dependent on the colour that contrasts best with the background against which the indicator shall be viewed.

- (5) Where required for use at night, the landing “T” shall either be illuminated or outlined by white lights.

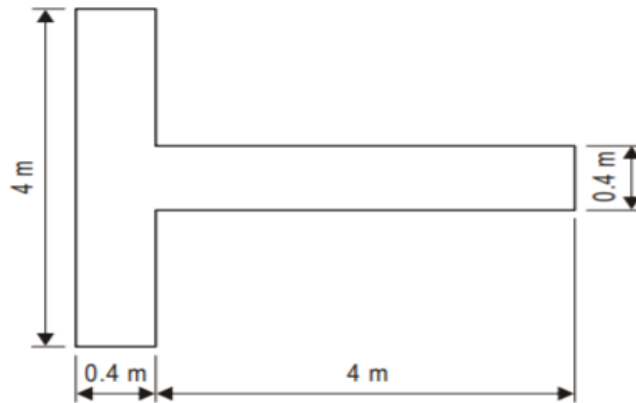

**Figure 5-1. Landing Direction Indicator**

### **80. Signalling Lamp**

- (1) An operator of a controlled aerodrome shall ensure that a signalling lamp is provided at the aerodrome control tower.
- (2) A signalling lamp shall be capable of producing red, green and white signals, and of:
  - (a) being aimed manually at any target as required;
  - (b) giving a signal in any one colour followed by a signal in either of the two other colours; and
  - (c) transmitting a message in any one of the three colours by Morse Code up to a speed of at least four words per minute.
- (3) When selecting the green light, use shall be made of the restricted boundary of green as specified in the Third Schedule section 2.1.2. lamp is intended for use in the daytime the intensity of the coloured light shall be
- (4) The beam spread shall not be less than  $1^\circ$  nor greater than  $3^\circ$ , with negligible light beyond  $3^\circ$ . When the signalling not less than 6 000 cd.

### **81. Signal Panel and Signalling Area**

- (1) The Authority may where it deems necessary, require a signal panel and a signal area to be provided at an aerodrome for safe operation of aircraft.
- (2) Where provided, the signal area shall:
  - (a) be located so as to be visible for all angles of azimuth above an angle of  $10^\circ$  above the horizontal when viewed from a height of 300 m.
  - (b) be an even horizontal surface at least 9 m square.
  - (c) have a colour chosen to contrast with the colours of the signal panels used, and it shall be surrounded by a white border not less than 0.3 m wide.
- (3) The aerodrome operator shall ensure that the location and the characteristics of the signal area is provided in accordance with these regulations.

## **Markings**

### **82. General Requirements for Markings**

- (1) An aerodrome operator shall provide markings for paved runway centreline, paved runway edge, paved runway threshold, paved runway touchdown zone, paved runway holding position, aiming point, paved runway side stripe, paved runway turn pad, taxiways, aprons and intermediate holding positions at an aerodrome, in accordance with these regulations.
- (2) Runway marking shall be white in colour.
- (3) Taxiway markings, runway turn pad markings and aircraft stand markings shall be yellow in colour.
- (4) Apron safety-lines shall be of a conspicuous colour, which shall contrast with that used for aircraft stand markings.
- (5) At aerodromes where operations take place at night, pavement markings shall be made with reflective materials designed to enhance the visibility of the markings.
- (6) An unpaved taxiway shall be provided, so far as practicable, with the markings prescribed for paved taxiways.
- (7) The application, location and the characteristics of markers for unpaved runway edge markers, stop way edge markers, taxiway edge markers, taxiway centreline markers and boundary markers shall be in accordance with these regulations.

### **83. Interruption of Runway Markings**

- (1) An aerodrome operator shall ensure that, at an intersection of two or more runways the markings of the more important runway, except for the runway side stripe marking, shall be displayed and the markings of the other runway(s) shall be interrupted.
- (2) Subject to sub-regulation (1) the runway side stripe marking of the more important runway may be either continued across the intersection or interrupted.
- (3) The order of importance of runways for the display of runway markings shall be as follows:
  - (a) 1st — precision approach runway;
  - (b) 2nd — non-precision approach runway; and
  - (c) 3rd — non-instrument runway.
- (4) At an intersection of a runway and taxiway the markings of the runway shall be displayed and the markings of the taxiway interrupted, except that runway side stripe markings may be interrupted.

### **84. Runway Designation Marking**

- (1) An aerodrome operator shall ensure that a runway designation marking is provided at the thresholds of a paved runway and shall be as far as practicable, at the thresholds of an unpaved runway.

- (2) The aerodrome operator shall designate runway marking located at a threshold as shown in the Figure below as appropriate.

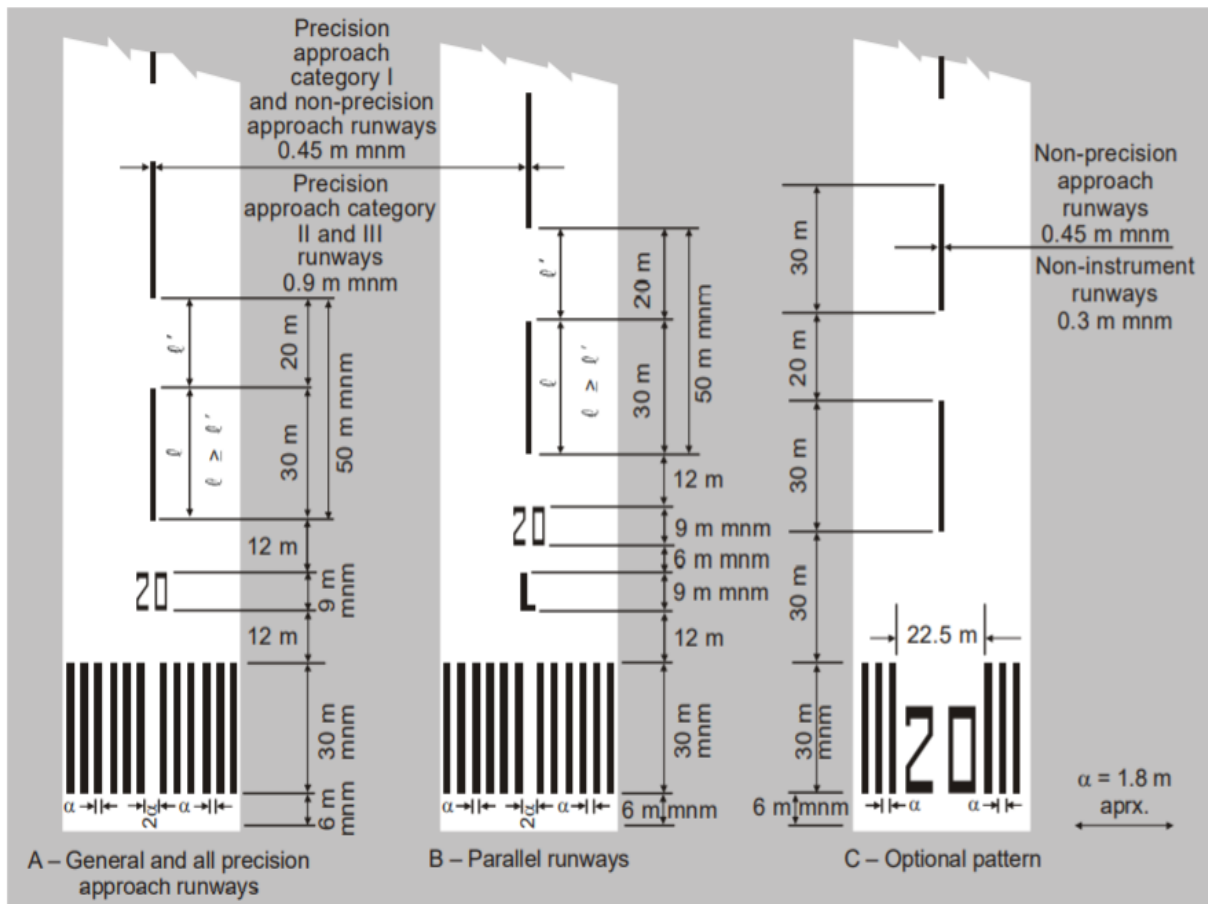

**Figure 5-2. Runway designation, centre line and threshold markings**

- (3) Where the runway threshold is displaced from the extremity of the runway, a sign showing the designation of the runway may be provided for aeroplanes taking off.
- (4) A runway designation marking shall consist of a two-digit number and on parallel runways shall be supplemented with a letter provided.
- (5) On a single runway, dual parallel runways and triple parallel runways the two-digit number shall be the whole number nearest the one-tenth of the magnetic North when viewed from the direction of approach.
- (6) On four or more parallel runways, one set of adjacent runways shall be numbered to the nearest one-tenth magnetic azimuth and the other set of adjacent runways numbered to the next nearest one-tenth of the magnetic azimuth provided that, when the above rule shall give a single digit number, it shall be preceded by a zero.
- (7) In the case of parallel runways, each runway designation number shall be supplemented by a letter in the order shown from left to right when viewed from the direction of approach as follows:
- for two parallel runways: “L” “R”;
  - for three parallel runways: “L” “C” “R”;
  - for four parallel runways: “L” “R” “L” “R”;
  - for five parallel runways: “L” “C” “R” “L” “R” or “L” “R” “L” “C” “R”; and

- (e) for six parallel runways: “L” “C” “R” “L” “C” “R”.
- (8) The numbers and letters shall be in the form and proportion shown in the figure 5-3 as provided under regulation 86(4).
- (9) The dimensions shall be not less than those shown in figure 5-2, but where the numbers are incorporated in the threshold marking, larger dimensions shall be used in order to fill adequately the gap between the stripes of the threshold marking.

**85. Runway Centreline Marking**

- (1) An aerodrome operator shall provide a runway centre line marking on a paved runway and it shall be located along the centre line of the runway between the runway designation markings as shown in figure 5-2, except when interrupted in compliance with Regulation 82(1).
- (2) A runway centre line marking shall consist of a line of uniformly spaced stripes and gaps and the length of:
  - (a) a stripe and the gap shall be not less than 50 m or more than 75 m; and
  - (b) each stripe shall be at least equal to the length of the gap or 30 m, whichever is greater.
- (3) The width of the stripes shall be not less than:
  - (a) 0.90 m on precision approach category II and III runways;
  - (b) 0.45 m on non-precision approach runways where the code number is 3 or 4, and precision approach category I runways; and
  - (c) 0.30 m on non-precision approach runways where the code number is 1 or 2, and on non-instrument runways.

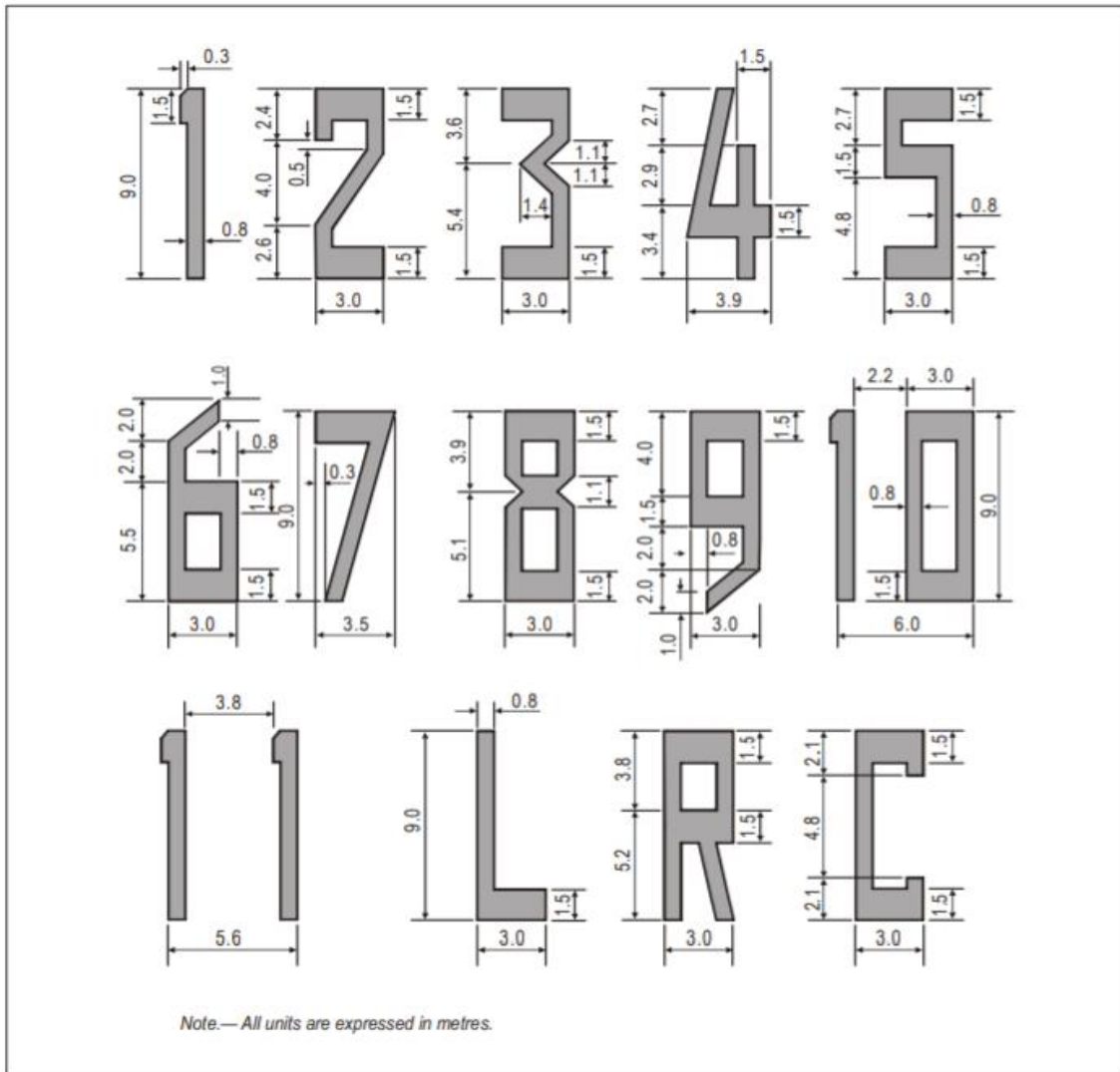

**Figure 5-3. Form and Proportions of Numbers and Letters for Runway Designation Markings**

**86. Threshold Marking**

- (1) An aerodrome operator shall ensure that threshold marking is provided at the threshold of a paved instrument runway, and of a paved non-instrument runway where the code number is 3 or 4 and the runway is intended for use by international commercial air transport.
- (2) The aerodrome operator shall provide threshold marking at the threshold of a paved non-instrument runway where the code number is 3 or 4 and the runway is intended for use by other than international commercial air transport.
- (3) The aerodrome operator shall provide a threshold marking, so far as practicable, at the thresholds of an unpaved runway.
- (4) The aerodrome operator shall ensure that, stripes of the threshold marking commence 6 m from the threshold.
- (5) The aerodrome operator shall ensure that runway threshold marking consist of a pattern of longitudinal stripes of uniform dimensions disposed symmetrically about the centre line of a runway as shown in figure 5-2 above for a runway width of 45 m. The number of stripes shall be in accordance with the runway width as follows:

<b>Runway width</b>	<b>Number of stripes</b>
---------------------	--------------------------

18 m	4
23 m	6
30 m	8
45 m	12
60 m	16

except that on non-precision approach and non-instrument runways 45 m or greater in width, they may be as shown in figure above.

- (6) The stripes required by sub-regulation (4) and (5) shall extend laterally to within 3 m of the edge of a runway or to a distance of 27 m on either side of a runway centre line, whichever results in the smaller lateral distance;
- (7) Where a runway designation marking is placed within a threshold marking there shall be a minimum of three stripes on each side of the centre line of the runway;
- (8) Where a runway designation marking is placed above a threshold marking, the stripes shall be continued across the runway;
- (9) The stripes shall be at least 30 m long and approximately 1.80 m wide with spacing of approximately 1.80 m between them except that, where the stripes are continued across a runway, a double spacing shall be used to separate the two stripes nearest the centre line of the runway, and in the case where the designation marking is included within the threshold marking this spacing shall be 22.5 m.
- (10) Where a threshold is displaced from the extremity of a runway or where the extremity of a runway is not square with the runway centre line, a transverse stripe as shown in Figure 5-4 (B) shall be added to the threshold marking.
- (11) A transverse stripe shall be not less than 1.80 m wide and where a runway threshold is permanently displaced, arrows conforming to Figure 5-4 (B) shall be provided on the portion of the runway before the displaced threshold.
- (12) When a runway threshold is temporarily displaced from the normal position, it shall be marked shown in figure 5-4(A) or 5-4 (B) and all markings prior to the displaced threshold shall be obscured except the runway centre-line marking, which shall be converted to arrows.

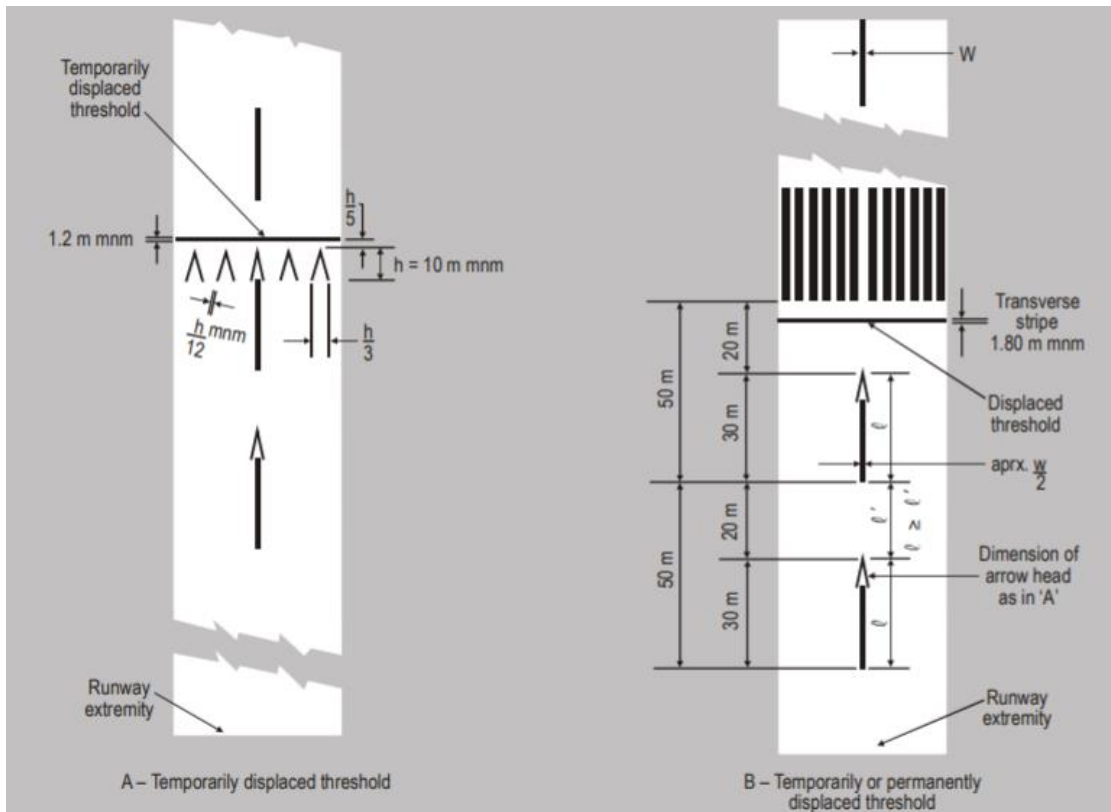

**Figure 5-4. Displaced Threshold Markings**

**87. Aiming Point Marking**

- (1) The aerodrome operator shall provide an aiming point marking at each approach end of a paved instrument runway where the code number is 2, 3 or 4.
- (2) The aerodrome operator shall provide an aiming point marking at each approach end of:
  - (a) a paved non-instrument runway where the code number is 3 or 4
  - (b) a paved instrument runway where the code number is 1, when additional conspicuity of the aiming point is desirable.
- (3) The aiming point marking shall commence not closer to the threshold than the distance indicated in the appropriate column of Table 5-1 except that, on a runway equipped with a visual approach slope indicator system, the beginning of the marking shall be coincident with the visual approach slope origin.
- (4) An aiming point marking shall consist of two conspicuous stripes.
- (5) Subject to sub-regulation (4) the dimensions of the stripes and the lateral spacing between their inner sides shall be in accordance with the provisions of the appropriate column of Table 5-1.
- (6) Where a touchdown zone marking is provided, the lateral spacing between the markings shall be the same as that of the touch-down zone marking.

**Table 5-1. Location and Dimensions of Aiming Point Marking**

Landing distance available				
Location and dimensions	Less than 800m	800m up to but not including 1200m	1200m up to but not including 2400m	2400m and above
(1)	(2)	(3)	(4)	(5)
Distance from threshold to beginning of marking	150 m	250m	300 m	400 m
Length of stripe <sup>a</sup>	30–45 m	30–45 m	45–60 m	45–60 m
Width of stripe	4 m	6m	6–10 m <sup>b</sup>	6–10 m <sup>b</sup>
Lateral spacing between inner sides of stripes	6m <sup>c</sup>	9m <sup>c</sup>	18–22.5 m	18–22.5 m
a.	The greater dimensions of the specified ranges are intended to be used where increased conspicuity is required.			
b.	The lateral spacing may be varied within these limits to minimize the contamination of the marking by rubber deposits.			
c.	These figures were deduced by reference to the outer main gear wheel span which is element 2 of the aerodrome reference code at Part 2, Table 1-1.			

### 88. Touchdown Zone Marking

- (1) The aerodrome operator shall provide a touchdown zone marking in the touchdown zone of a paved precision approach runway where the code number is 2, 3 or 4.
- (2) The aerodrome operator shall ensure that a touchdown zone marking is provided in the touchdown zone of a paved non-precision approach or non-instrument runway where the code number is 3 or 4 and additional conspicuity of the touchdown zone is desirable.
- (3) The aerodrome operator shall ensure that a touchdown zone marking consist of pairs of rectangular markings symmetrically disposed about the runway centre line with the number of such pairs related to the landing distance available and, where the marking is to be displayed at both the approach directions of a runway:

#### Landing distance available or the distance between thresholds

Landing distance available or the distance between thresholds	Pair(s) of markings
Less than 900 m	1
900m up to but not including 1 200 m	2
1 200m up to but not including 1 500 m	3
1 500m up to but not including 2 400 m	4
2 400m or more	6

- (4) The aerodrome operator shall ensure that, a touchdown zone marking conform to either of the two patterns shown in Figure 5-5. For the pattern shown in Figure 5-5 (A), the markings shall be not less than 22.5 m long and 3 m wide.

- (5) Subject to sub-regulation (4), the aerodrome operator shall ensure that, the pattern shown in Figure 5-5 (B), each stripe of each marking shall be not less than 22.5 m long and 1.8 m wide with a spacing of 1.5 m between adjacent stripes.
- (6) The lateral spacing between the inner sides of the rectangles shall be equal to that of the aiming point marking where provided.
- (7) Where an aiming point marking is not provided, the lateral spacing between the inner sides of the rectangles shall correspond to the lateral spacing specified for the aiming point marking in Table 5-1 (columns 2, 3, 4 or 5, as appropriate).
- (8) The pairs of markings shall be provided at longitudinal spacings of 150 m beginning from the threshold, except that pairs of touchdown zone markings coincident with or located within 50 m of an aiming point marking shall be deleted from the pattern.
- (9) On a non-precision approach runway where the code number is 2, an additional pair of touchdown zone marking stripes shall be provided 150 m beyond the beginning of the aiming point marking.

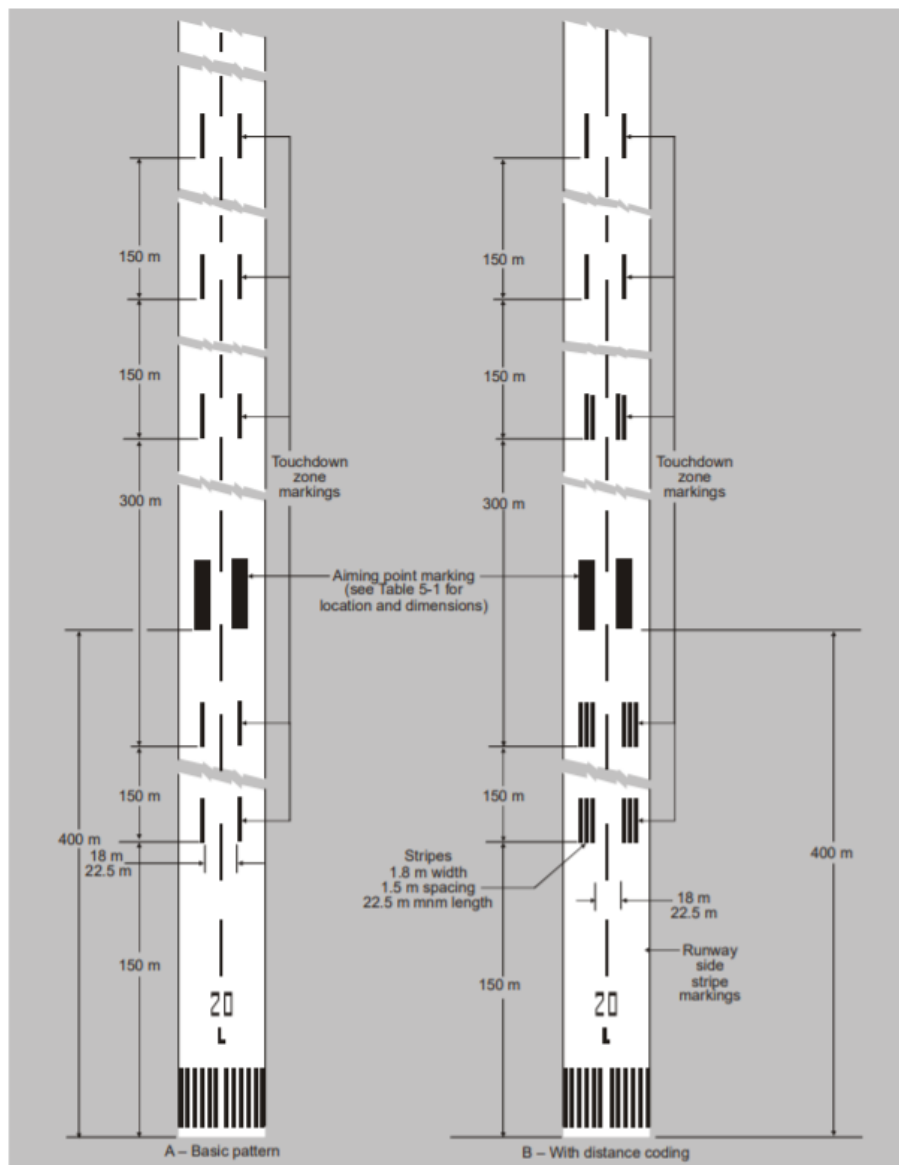

**Figure 5-5. Aiming Point and Touchdown Zone Markings (Illustrated for A Runway with A Length Of 2 400 M or More)**

## **89. Runway Side Stripe Marking**

- (1) An aerodrome operator shall provide runway side stripe marking between the thresholds of a paved runway where there is a lack of contrast between the runway edges and the shoulders or the surrounding terrain.
- (2) The aerodrome operator shall provide a runway side stripe marking on a precision approach runway irrespective of the contrast between the runway edges and the shoulders or the surrounding terrain.
- (3) The aerodrome operator shall provide a runway side stripe marking consisting of two stripes, one placed along each edge of the runway with the outer edge of each stripe approximately on the edge of the runway, except that, where the runway is greater than 60 m in width, the stripes shall be located 30 m from the runway centre line.
- (4) The aerodrome operator shall ensure that where a runway turn pad is provided, the runway side stripe marking shall be continued between the runway and the runway turn pad.
- (5) The aerodrome operator shall ensure that, a runway side stripe have an overall width of at least 0.9 m on runways 30 m or more in width and at least 0.45 m on narrower runways.

## **90. Taxiway Centreline Markings**

- (1) An aerodrome operator shall provide Taxiway centre line marking on a paved taxiway and apron where the code number is 3 or 4 in such a way as to provide continuous guidance between the runway centre line and aircraft stand.
- (2) The aerodrome operator shall provide Taxiway centre line marking on a paved taxiway and apron where the code number is 1 or 2 in such a way as to provide continuous guidance between the runway centre line and aircraft packed.
- (3) The aerodrome operator shall provide Taxiway centre line marking on a paved runway when the runway is part of a standard taxi-route and:
  - (a) there is no runway centre line marking; or
  - (b) where the taxiway centre line is not coincident with the runway centre line.
- (4) Where it is necessary to denote the proximity of a runway holding position, enhanced taxiway centre line marking shall be provided and where provided, enhanced taxiway centre line marking shall be installed at each taxiway/runway intersections.
- (5) On a straight section of a taxiway, the taxiway centre line marking shall be located along the taxiway centre line.
- (6) On a taxiway curve the marking shall continue from the straight portion of the taxiway at a constant distance from the outside edge of the curve.
- (7) At an intersection of a taxi-way with a runway where the taxiway serves as an exit from the runway, the taxiway centre line marking shall be curved into the runway centre line marking.

- (8) The aerodrome operator shall ensure that, taxiway centre line marking shall be extended parallel to the runway centre line marking for a distance of at least 60 m beyond the point of tangency where the code number is 3 or 4, and for a distance of at least 30 m where the code number is 1 or 2.
- (9) Where taxiway centre line marking is provided on a runway, the marking shall be located on the centre line of the designated taxiway.
- (10) On a straight section of a taxiway the taxiway centre line marking shall be located along the taxiway centre line.
- (11) On a taxiway curve the marking shall continue from the straight portion of the taxiway at a constant distance from the outside edge of the curve.
- (12) At an intersection of a taxi-way with a runway where the taxiway serves as an exit from the runway, the taxiway centre line marking shall be curved into the runway centre line marking.
- (13) The taxiway centre line marking shall be extended parallel to the runway centre line marking for a distance of at least 60 m beyond the point of tangency where the code number is 3 or 4, and for a distance of at least 30 m where the code number is 1 or 2.

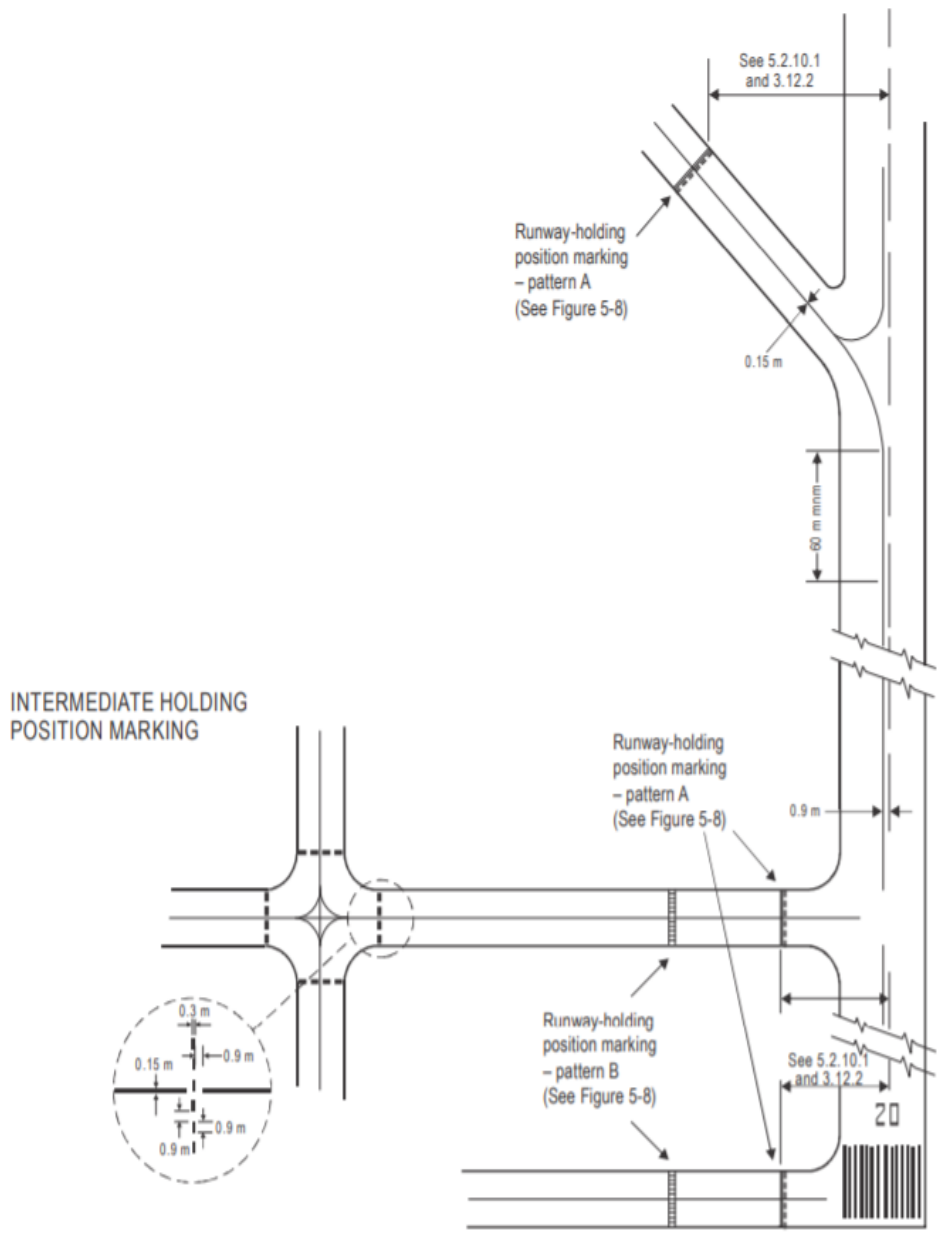

**Figure 5-6. Taxiway Markings (Shown with Basic Runway Markings)**

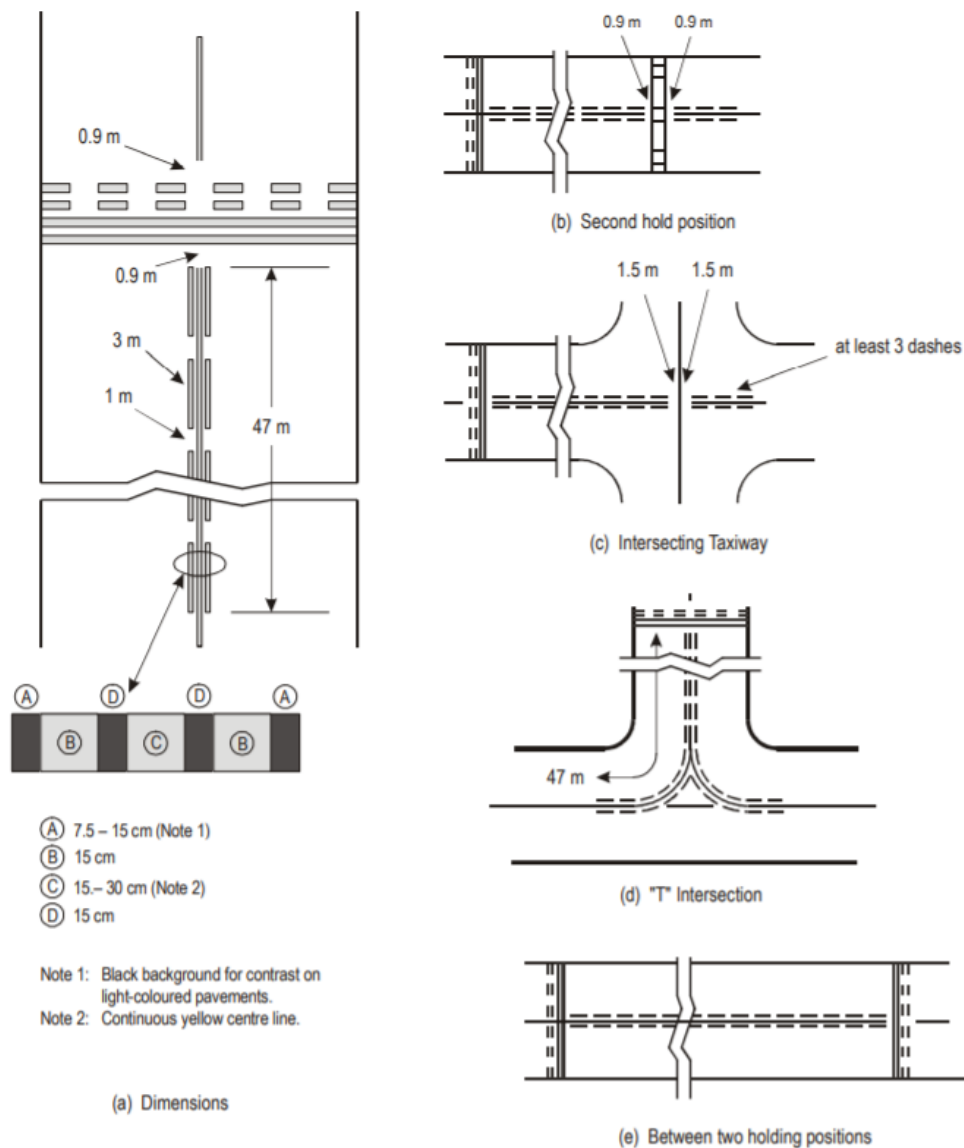

**Figure 5-7. Enhanced Taxiway Centre Line Marking**

An enhanced taxiway centre line marking shall extend from the runway-holding position to a distance of up to 47m in the direction of travel away from the runway.

- (14) Where the enhanced taxiway centre line marking intersects another runway-holding position marking, such as for a precision approach category II or III runway that is located within 47 m of the first runway-holding position marking, the enhanced taxiway centre line marking shall be interrupted 0.9 m prior to and after the intersected runway-holding position marking.
- (15) The enhanced taxiway centre line marking shall continue beyond the intersected runway-holding position marking for at least three dashed line segments or 47 m from start to finish, whichever is greater.
- (16) Where the enhanced taxiway centre line marking continues through a taxiway/taxiway intersection that is located within 47 m of the runway-holding position marking, the enhanced taxiway centre line marking shall be interrupted 1.5 m prior to and after the

point where the intersected taxiway centre line crosses the enhanced taxiway centre line.

- (17) The enhanced taxiway centre line marking shall continue beyond the taxiway/taxiway intersection for at least three dashed line segments or 47 m from start to finish, whichever is greater.
- (18) Where two taxiway centre lines converge at or before the runway-holding position marking, the inner dashed line shall not be less than 3 m in length.
- (19) (Where there are two opposing runway-holding position markings and the distance between the markings is less than 94 m, the enhanced taxiway centre line markings shall extend over this entire distance.
- (20) The enhanced taxiway centre line markings shall not extend beyond either runway-holding position marking.
- (21) A taxiway centre line marking shall be at least 15cm in width and continuous in length except where it intersects with a runway-holding position marking or an intermediate holding position marking.
- (22) Enhanced taxiway centre line marking shall be as shown in Figure 5-7.

## **91. Runway Turn Pad Marking**

- (1) Where a runway turn pad is provided, the aerodrome operator shall provide a runway turn pad marking to ensure continuous guidance to enable an aeroplane complete a 180-degree turn and align with runway centre line.
- (2) The runway turn pad marking shall be curved from the runway centre line into the turn pad.
- (3) Subject to sub-regulation (2) the radius of the curve shall be compatible with the manoeuvring capability and normal taxiing speeds of the aeroplanes for which the runway turn pad is intended.
- (4) The intersection angle of the runway turn pad marking with the runway centre line shall not be greater than 30 degrees.
- (5) The runway turn pad marking shall be extended parallel to the runway centre line marking for a distance of at least 60 m beyond the point of tangency where the code number is 3 or 4, and for a distance of at least 30 m where the code number is 1 or 2.
- (6) A runway turn pad marking shall guide the aeroplane in such a way as to allow a straight portion of taxiing before the point where a 180-degree turn is to be made.
- (7) The straight portion of the runway turn pad marking referred to in sub-regulation (6) shall be parallel to the outer edge of the runway turn pad.
- (8) The design of the curve allowing the aeroplane to negotiate a 180-degree turn shall be based on a nose wheel steering angle not exceeding 45 degrees.
- (9) The design of the turn pad marking shall be such that, when the cockpit of the aeroplane remains over the runway turn pad marking, the clearance distance between any wheel of the aeroplane landing gear and the edge of the runway turn pad shall be not less than those specified in Regulation 47(6).

- (10) A runway turn pad marking shall be at least 15 cm in width and continuous in length.

**92. Runway-Holding Position Marking**

- (1) An aerodrome operator shall ensure that, a runway-holding position marking is displayed along a runway-holding position.
- (2) At an intersection of a taxiway and a non-instrument, non-precision approach or take-off runway, the runway holding position marking shall be as shown in Figure 5-8, pattern A.
- (3) Where a single runway-holding position is provided at an intersection of a taxiway and a precision approach category I, II or III runway, the runway-holding position marking shall be as shown in Figure 5-8, pattern A.
- (4) Where two or three runway-holding positions are provided at such an intersection, the runway-holding position marking closer (closest) to the runway shall be as shown in Figure 5-8, pattern A and the markings farther from the runway shall be as shown in Figure 5-8, pattern B.
- (5) The runway-holding position marking displayed at a runway-holding position shall be established as prescribed by these regulations under regulation. (3.12.3)
- (6) Until 26 November 2026, the dimensions of runway-holding position markings shall be as shown in Figure 5-8, pattern A1 (or A2) or pattern B1 (or B2), as appropriate.
- (7) As of 26 November 2026, the dimensions of runway-holding position markings shall be as shown in Figure 5-8, pattern A2 or pattern B2, as appropriate.
- (8) Where increased conspicuity of the runway-holding position is required, the dimensions of runway-holding position marking shall be done shown in figure 5-8, pattern A2 or pattern B2, as appropriate.
- (9) Where a pattern B runway-holding position marking is located on an area where it shall exceed 60 m in length, the term “CAT II” or “CAT III” as appropriate shall be marked on the surface at the ends of the runway-holding position marking and at equal intervals of 45 m maximum between successive marks.
- (10) The letters referred to in sub-regulation (9) shall be not less than 1.8 m high and shall be placed not more than 0.9 m beyond the holding position marking.
- (11) The runway-holding position marking displayed at a runway or runway intersection shall be perpendicular to the center line of the runway forming part of the standard taxi-route.
- (12) The pattern of the marking referred to in sub-regulation (11) shall be as shown in the figure below:

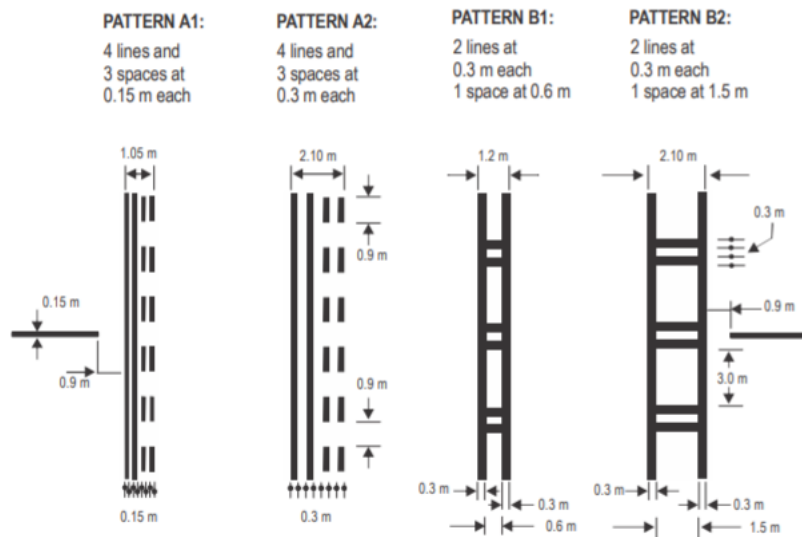

**Figure 5-8. Runway-Holding Position Markings**

Note. — Patterns A1 and B1 are no longer valid after 2026.

### 93. Intermediate Holding Position Marking

- (1) An aerodrome operator shall ensure that, an intermediate holding position marking is displayed along an intermediate holding position.
- (2) Where an intermediate holding position marking is displayed at an intersection of two paved taxiways, it shall be:
  - (a) located across the taxiway at sufficient distance from the near edge of the intersecting taxiway to ensure safe clearance between taxiing aircraft.
  - (b) coincident with a stop bar or intermediate holding position lights, where provided.
- (3) An intermediate holding position marking shall consist of a single broken line as shown in figure 5-.

### 94. VOR Aerodrome Checkpoint Marking

- (1) An operator shall ensure that where a VOR aerodrome checkpoint is established at an aerodrome, it is indicated by a VOR aerodrome checkpoint marking and sign.
- (2) The VOR aerodrome checkpoint marking shall be centered on the spot at which an aircraft is to be parked to receive the correct VOR signal.
- (3) A VOR aerodrome checkpoint marking shall consist of a circle 6 m in diameter and have a line width of 15 cm (see Figure 5-9 (A)).
- (4) When it is preferable for an aircraft to be aligned in a specific direction, a line shall be provided that passes through the center of the circle on the desired azimuth.
- (5) The line referred to in sub-regulation (4) shall extend 6 m outside the circle in the desired direction of heading and terminate in an arrowhead and the width of the line shall be 15 cm (see Figure 5-9 (B))

- (6) A VOR aerodrome checkpoint marking shall preferably be white in colour but shall differ from the colour used for the taxiway markings.

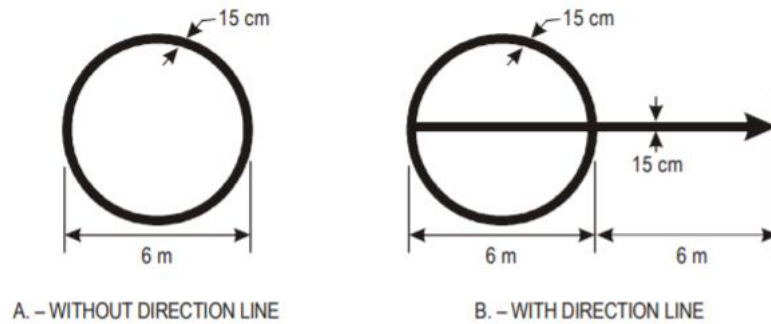

*Note.— A direction line need only be provided when an aircraft must be aligned in a specific direction.*

**Figure 5-9. VOR Aerodrome Checkpoint Marking**

### 95. Aircraft Stand Markings

- (1) An operator shall provide aircraft stand markings for designated parking positions on a paved apron.
- (2) Aircraft stand markings on a paved apron shall be located so as to provide the clearances specified in Regulation 60 (6) when the nose wheel follows the stand marking.
- (3) Aircraft stand markings shall include such elements as stand identification, lead-in line, turn bar, turning line, alignment bar, stop line and lead-out line, as are required by the parking configuration and to complement other parking aids.
- (4) An aircraft stand identification (letter or number) shall be included in the lead-in line a short distance after the beginning of the lead-in line.
- (5) The height of the identification referred in sub-regulation (4) shall be adequate to be readable from the cockpit of aircraft using the stand.
- (6) Where two sets of aircraft stand markings are superimposed on each other in order to permit more flexible use of the apron and it is difficult to identify which stand marking shall be followed, or safety shall be impaired where the wrong marking was followed, then identification of the aircraft for which each set of markings is intended shall be added to the stand identification. Example: 2A-B747, 2B-F28
- (7) Lead-in, turning and lead-out lines shall normally be continuous in length and have a width of not less than 15 cm.
- (8) Subject to sub-regulation (7) where one or more sets of stand markings are superimposed on a stand marking, the lines shall be continuous for the most demanding aircraft and broken for other aircraft.
- (9) The curved portions of lead-in, turning and lead-out lines shall have radii appropriate to the most demanding aircraft type for which the markings are intended.

- (10) Where it is intended that an aircraft proceed in one direction only, arrows pointing in the direction to be followed shall be added as part of the lead-in and lead-out lines.
- (11) A turn bar shall be located at right angles to the lead-in line, abeam the left pilot position at the point of initiation of any intended turn.
- (12) The turn bar referred to in sub-regulation (11) shall have a length and width of not less than 6 m and 15 cm, respectively, and include an arrowhead to indicate the direction of turn.
- (13) Where more than one turn bar and/or stop line is required, they shall be coded.
- (14) An alignment bar shall be placed so as to be coincident with the extended center line of the aircraft in the specified parking position and visible to the pilot during the final part of the parking manoeuvre.
- (15) The alignment bar referred to in sub-regulation (14) shall have a width of not less than 15 cm.
- (16) A stop line shall be located at right angles to the alignment bar, abeam the left pilot position at the intended point of stop.
- (17) The stop line referred to in sub-regulation (16) shall have a length and width of not less than 6 m and 15 cm, respectively.

**96. Apron Safety Lines**

- (1) An aerodrome operator shall provide apron safety lines on a paved apron as required by the Parking configuration and ground facilities.
- (2) The operator shall ensure that, the pron safety lines are located so as to define the areas intended for use by ground vehicles and other aircraft servicing equipment to provide safe separation from aircraft.
- (3) Apron safety lines shall include such elements as wing tip clearance lines and service road boundary lines as required by the parking configurations and ground facilities.
- (4) An apron safety line shall be continuous in length and at least 10 cm in width.

**97. Road-Holding Positions**

- (1) An aerodrome operator shall provide road-holding position markings at all road entrances to a runway.
- (2) The road-holding position markings shall be located across the road at all the holding positions.
- (3) The road-holding position marking shall be in accordance with the local road traffic regulations.

**98. Mandatory Instruction Markings**

- (1) An aerodrome operator shall provide a mandatory instruction marking to identify a location Beyond which a taxiing aircraft or vehicle shall not proceed, unless authorized by the aerodrome control tower.

- (2) Where it is impracticable to install a mandatory instruction sign in accordance with Regulation 150 (1) the operator shall provide mandatory instruction marking or sign on the surface of the pavement to identify a location beyond which a taxiing aircraft or vehicle shall not proceed unless authorized by ATC.
- (3) Where operationally required, such as on taxiways exceeding 60 m in width, or to assist in the prevention of a runway incursion, a mandatory instruction sign shall be supplemented by a mandatory instruction marking.
- (4) The mandatory instruction marking on taxiways where the code letter is A, B, C or D shall be located across the taxiway equally placed about the taxiway center line and on the holding side of the runway-holding position marking as shown in Figure 5-10 (A).
- (5) Subject to sub-regulation (4) the distance between the nearest edge of the marking and the runway-holding position marking or the taxiway center line marking shall not be less than 1 m.
- (6) The mandatory instruction marking on taxiways where the code letter is E or F shall be located on both sides of the taxiway center line marking and on the holding side of the runway-holding position marking as shown in Figure 5-10 (B).
- (7) Subject to sub-regulation (6) the distance between the nearest edge of the marking and the runway-holding position marking or the taxiway center line marking shall be not less than 1 m.

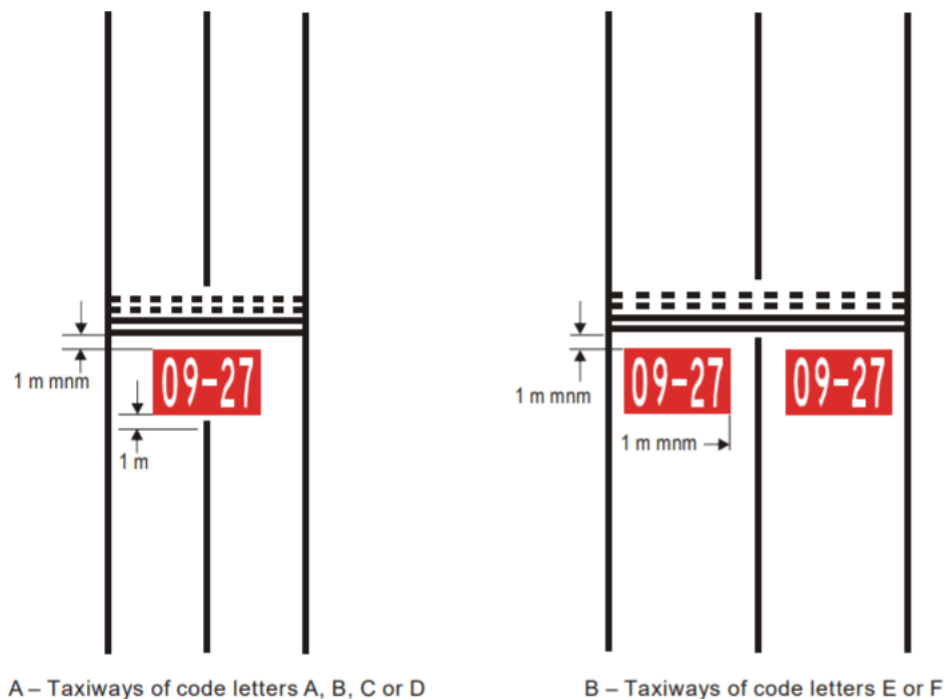

**Figure 5-10. Mandatory Instruction Marking**

- (8) Except where operationally required, a mandatory instruction marking shall not be located on a runway.

- (9) A mandatory instruction marking shall consist of an inscription in white on a red background.
- (10) Subject to sub-regulation (9), except for a “NO ENTRY” marking, the inscription shall provide
- (11) information identical to that of the associated mandatory instruction sign.
- (12) A “NO ENTRY” marking shall consist of an inscription in white reading “NO ENTRY” on a red background.
- (13) Where there is insufficient contrast between the marking and the pavement surface, the mandatory instruction marking shall include an appropriate border, preferably white or black.
- (14) The character height shall be 4 m for inscriptions where the code letter is C, D, E or F, and 2 m where the code letter is A or B.
- (15) The inscriptions referred to in sub-regulation (13) shall be in the form and proportions shown in Fifth Schedule to these Regulations.
- (16) The background shall be rectangular and extend a minimum of 0.5 m laterally and vertically beyond the extremities of the inscription.

## **99. Information Marking**

- (1) An operator shall display an information marking on the surface of a pavement where an information sign is required but is physically impractical to install, as determined by the Authority.
- (2) Where operationally required an information sign shall be supplemented by an information marking.
- (3) An information (location or direction) marking shall be displayed prior to and following complex taxiway intersections and where operational experience has indicated the addition of a taxiway location marking could assist flight crew ground navigation.
- (4) An information (location) marking shall be displayed on the pavement surface at regular intervals along taxiways of great length.
- (5) The information marking shall be displayed across the surface of the taxiway or apron where necessary and positioned so as to be legible from the cockpit of an approaching aircraft.
- (6) An information marking shall comprise the following characteristics:
  - (a) an inscription in yellow upon a black background, when it replaces or supplements a location sign; and
  - (b) an inscription in black upon a yellow background, when it replaces or supplements a direction or destination sign.
- (7) Where there is insufficient contrast between the marking background and the pavement surface, the marking shall include:
  - (a) a black border where the inscriptions are in black; and

- (b) a yellow border where the inscriptions are in yellow.
- (8) The character height shall be 4 m.
- (9) Subject to sub-regulation (8) the inscriptions shall be in the form and proportions shown in the Fifth Schedule to these Regulations.

**Lights**

**100. Laser Emissions Which May Endanger the Safety of Aircraft**

- (1) To protect the safety of aircraft against the hazardous effects of laser emitters, an operator shall establish the following protected zones around the aerodrome:
  - (a) a laser-beam free flight zone (LFFZ);
  - (b) a laser-beam critical flight zone (LCFZ); and
  - (c) a laser-beam sensitive flight zone.
- (2) Flight zones required by sub-regulation (1) shall be established in accordance with requirements of this regulation.
- (3) Sub-regulations (2) and (4) shall not apply to aerodromes in categories C, D, and E unless deemed necessary by the Authority.
- (4) The exposure levels and distances that adequately protect flight operations shall be determined as per figures 5-11, 5-12 and 5-13.

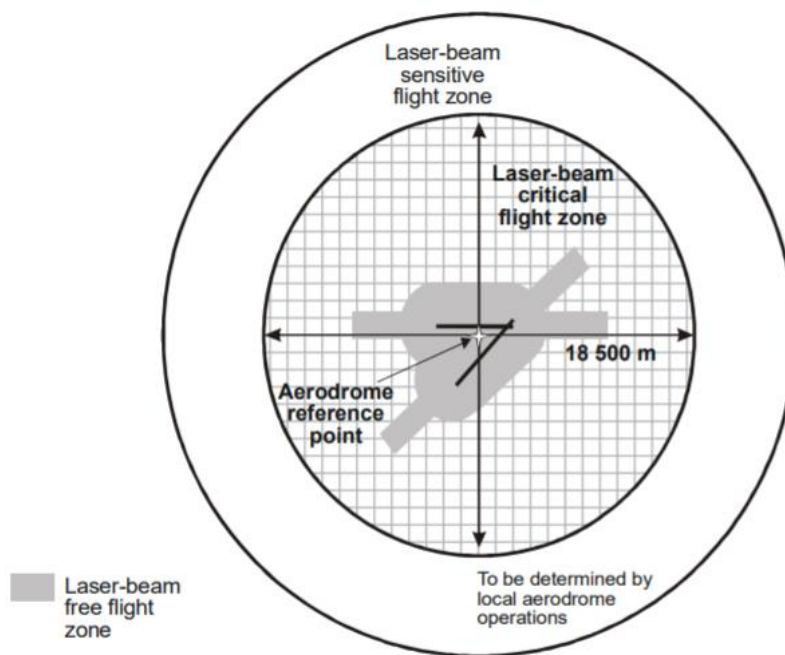

*Note.— The dimensions indicated are given as guidance only.*

**Figure 5-11. Protected flight zones**

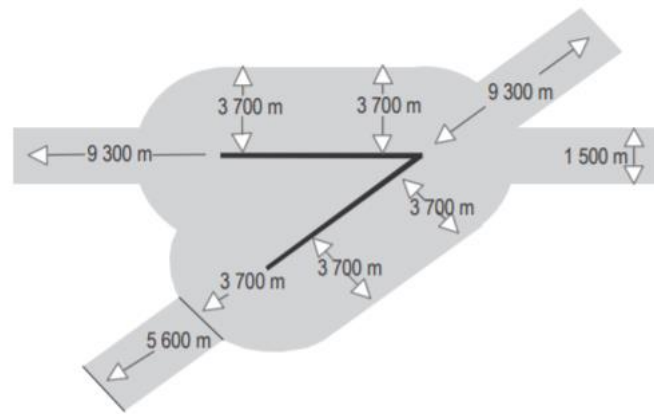

Note.— The dimensions indicated are given as guidance only.

**Figure 5-12. Multiple runway laser-beam free flight zone**

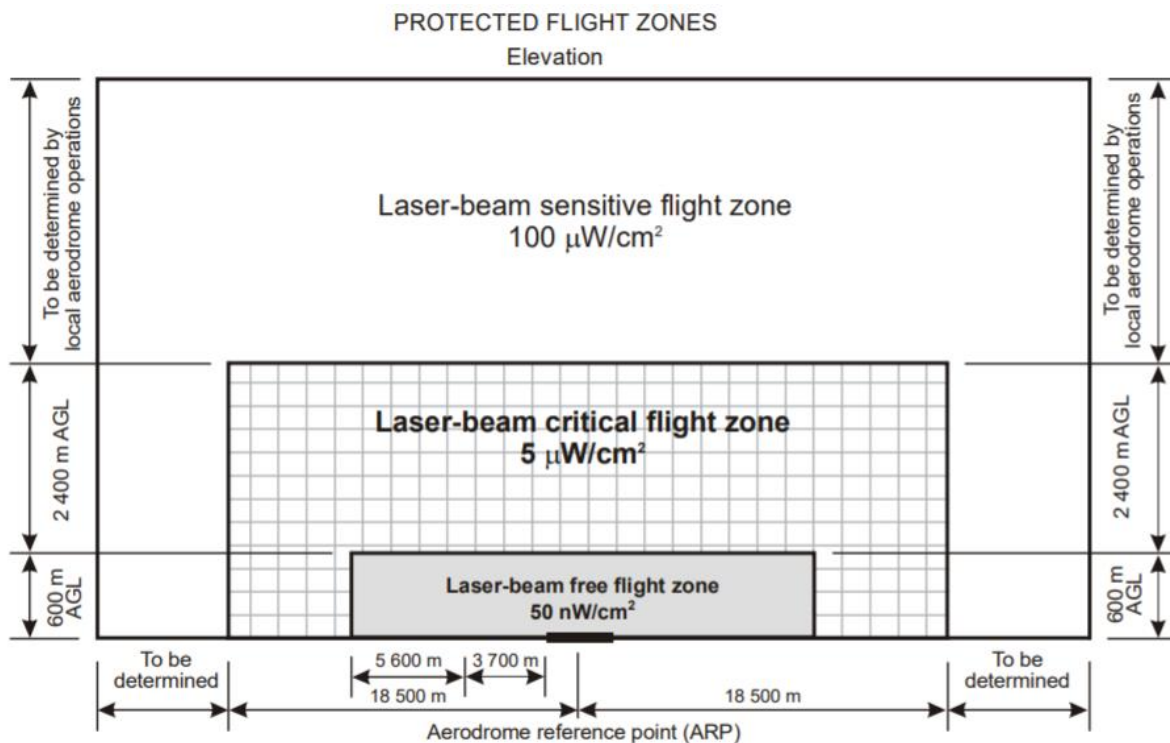

**Figure 5-13. Protected flight zones with indication of maximum irradiance levels for visible laser beams**

### 101. Elevated Approach Lights

- (1) An aerodrome operator shall ensure that, elevated approach lights and their supporting structures are frangible except that, in that portion of the approach lighting system beyond 300 m from the threshold
- (2) Where the height of a supporting structure exceeds 12 m, the frangibility requirement shall apply to the top 12 m only; and

- (3) Where a supporting structure is surrounded by non-frangible objects, only that part of the structure that extends above the surrounding objects shall be frangible.
- (4) When an approach light fixture or supporting structure is not in itself sufficiently conspicuous, it shall be suitably marked.

## **102. Elevated Lights**

An aerodrome operator shall ensure that elevated runway, stop-way and taxiway lights are frangible and their height shall be sufficiently low to preserve clearance for propellers and for the engine pods of jet aircraft.

## **103. Surface Lights**

- (1) Light fixtures inset in the surface of runways, stop-ways, taxiways and aprons shall be designed and fitted as to withstand being run over by the wheels of an aircraft without damage either to the aircraft or to the lights themselves.
- (2) The temperature produced by conduction or radiation at the interface between an installed inset light and an aircraft tire shall not exceed 160°C during a 10-minute period of exposure.

## **104. Light Intensity and Control**

- (1) The intensity of runway lighting shall be adequate for the minimum conditions of visibility and ambient light in which use of the runway is intended, and compatible with that of the nearest section of the approach lighting system when provided.
- (2) Where a high-intensity lighting system is provided, a suitable intensity control shall be incorporated to allow for adjustment of the light intensity to meet the prevailing conditions.
- (3) An aerodrome operator shall provide separate intensity controls or other suitable methods to ensure that the following systems, when installed, can be operated at compatible intensities:
  - (a) approach lighting system;
  - (b) runway edge lights;
  - (c) runway threshold lights;
  - (d) runway end lights;
  - (e) runway center line lights;
  - (f) runway touchdown zone lights; and
  - (g) taxiway center line lights.
- (4) On the perimeter of and within the ellipse defining the main beam in Fourth Schedule, Figures A2-1 to A2-10, the maximum light intensity value shall not be greater than three times the minimum light intensity value measured in accordance with Fourth Schedule, collective notes for Figures A2-1 to A2-11 and A2-26, Note 2.
- (5) On the perimeter of and within the rectangle defining the main beam in Fourth Schedule, Figures A2-12 to A2-20, the maximum light intensity value shall not be

greater than three times the minimum light intensity value measured in accordance with Fourth Schedule, collective notes for Figures A2-12 to A2-21.

#### **105. Emergency Lighting**

- (1) At an aerodrome provided with runway lighting and without a secondary power supply, the aerodrome operator shall provide sufficient emergency lights conveniently available for installation on at least the primary runway in the event of failure of the normal lighting system.
- (2) Where installed on a runway the emergency lights shall, as a minimum, conform to the configuration required for a non-instrument runway.
- (3) The colour of the emergency lights shall conform to the colour requirements for runway lighting, except that, where the provision of coloured lights at the threshold and the runway end is not practicable, all lights may be variable white or as close to variable white as practicable.

#### **106. Provision of Aeronautical Beacons**

- (1) Where operationally necessary an aerodrome operator shall provide aerodrome beacon or an identification beacon at each aerodrome intended for use at night.
- (2) The operational requirement shall be determined having regard to the requirements of the air traffic using the aerodrome, the conspicuity of the aerodrome features in relation to its surroundings and the installation of other visual and non-visual aids useful in locating the aerodrome.

#### **107. Aerodrome Beacon**

- (1) An aerodrome beacon shall be provided at an aerodrome intended for use at night where one or more of the following conditions exist:
  - (a) aircraft navigate predominantly by visual means;
  - (b) reduced visibilities are frequent; or
  - (c) it is difficult to locate the aerodrome from the air due to surrounding lights or terrain.
- (2) The aerodrome beacon shall be located on or adjacent to the aerodrome in an area of low ambient back-ground lighting.
- (3) The location of the beacon shall be such that the beacon is not shielded by objects in significant directions and does not dazzle a pilot approaching to land.
- (4) The aerodrome beacon shall show either coloured flashes alternating with white flashes, or white flashes only.
- (5) The frequency of total flashes shall be from 20 to 30 per minute.
- (6) Where used, the coloured flashes emitted by beacons at land aerodromes shall be green and coloured flashes emitted by beacons at water aerodromes shall be yellow.
- (7) In the case of a combined water and land aerodrome, coloured flashes, where used, shall have the colour characteristics of whichever section of the aerodrome is designated as the principal facility.

- (8) The light from the beacon shall show at all angles of azimuth.
- (9) The vertical light distribution shall extend upwards from an elevation of not more than 1° to an elevation determined by the Authority to be sufficient to provide guidance at the maximum elevation at which the beacon is intended to be used and the effective intensity of the flash shall be not less than 2 000 cd.
- (10) At locations where a high ambient background lighting level cannot be avoided, the effective intensity of the flash shall be required to be increased by a factor up to a value of 10.

#### **108. Identification Beacon**

- (1) An identification beacon shall be provided at an aerodrome which is intended for use at night and cannot be easily identified from the air by other means.
- (2) The identification beacon shall be located on the aerodrome in an area of low ambient background lighting.
- (3) The location of the beacon shall be such that the beacon is not shielded by objects in significant directions and does not dazzle a pilot approaching to land.
- (4) An identification beacon at a land aerodrome shall show at all angles of azimuth.
- (5) The vertical light distribution shall extend upwards from an elevation of not more than 1° to an elevation determined by the Authority to be sufficient to provide guidance at the maximum elevation at which the beacon is intended to be used and the effective intensity of the flash shall be not less than 2 000 cd.
- (6) At locations where a high ambient background lighting level cannot be avoided, the effective intensity of the flash shall be required to be increased by a factor up to a value of 10.
- (7) An identification beacon shall show flashing-green at a land aerodrome and flashing-yellow at a water aerodrome.
- (8) The identification characters shall be transmitted in the International Morse Code.
- (9) The speed of transmission shall be between six and eight words per minute, the corresponding range of duration of the Morse dots being from 0.15 to 0.2 seconds per dot.

#### **109. Approach Lighting System**

- (1) Where physically practicable, a simple approach lighting system shall be provided by the operator as specified in Regulation 111 to serve a non-instrument runway where the code number is 3 or 4 and intended for use at night, except when the runway is used only in conditions of good visibility and sufficient guidance is provided by other visual aids.
- (2) Where physically practicable, a simple approach lighting system as specified in Regulation 111 shall be provided to serve a non-precision approach runway, except when the runway is used only in conditions of good visibility or sufficient guidance is provided by other visual aids.

- (3) Where physically practicable, a precision approach category I lighting system as specified in Regulation 112 shall be provided by the operator to serve a precision approach runway category I.
- (4) A precision approach category II and III lighting system as specified in Regulation 113 shall be provided to serve a precision approach runway category II or III.

#### **110. Simple Approach Lighting System**

- (1) An aerodrome operator shall ensure that, simple approach lighting system consist of a row of lights on the extended centre line of the runway extending, whenever possible, over a distance of not less than 420 m from the threshold with a row of lights forming a crossbar 18 m or 30 m in length at a distance of 300 m from the threshold.
- (2) The lights forming the crossbar shall be as nearly as practicable in a horizontal straight line at right angles to, and bisected by, the line of the center line lights.
- (3) The lights of the crossbar shall be spaced so as to produce a linear effect, except that, when a crossbar of 30 m is used, gaps may be left on each side of the center line.
- (4) These gaps shall be kept to a minimum to meet local requirements and each shall not exceed 6 m.
- (5) The lights forming the center line shall be placed at longitudinal intervals of 60 m, except that, when it is desired to improve the guidance, an interval of 30 m may be used.
- (6) The innermost light shall be located either 60 m or 30 m from the threshold, depending on the longitudinal interval selected for the center line lights.
- (7) Where it is not physically possible to provide a center line extending for a distance of 420 m from the threshold, it shall be extended to 300 m so as to include the crossbar
- (8) Where this is not possible, the center line lights shall be extended as far as practicable, and each center line light shall then consist of a barrette at least 3 m in length.
- (9) Subject to the approach system having a crossbar at 300 m from the threshold, an additional crossbar may be provided at 150 m from the threshold.
- (10) The system shall lie as nearly as practicable in the horizontal plane passing through the threshold, provided that:
  - (a) no object other than an ILS or MLS azimuth antenna shall protrude through the plane of the approach lights within a distance of 60 m from the centre line of the system; and
  - (b) no light other than a light located within the central part of a crossbar or a centre line barrette (not their extremities) shall be screened from an approaching aircraft.
- (11) Any ILS or MLS azimuth antenna protruding through the plane of the lights shall be treated as an obstacle and marked and lighted accordingly. The lights of a simple approach lighting system shall be fixed lights and the colour of the lights shall be such as to ensure that the system is readily distinguishable from other aeronautical ground lights, and from extraneous lighting where present.
- (12) Each center line light shall consist of either:

- (a) a single source; or
  - (b) a barrette at least 3 m in length.
- (13) Where provided for a non-instrument runway, the lights shall show at all angles in azimuth necessary to a pilot on base leg and final approach (b).
  - (14) The intensity of the lights shall be adequate for all conditions of visibility and ambient light for which the system has been provided.
  - (15) Where provided for a non-precision approach runway, the lights shall show at all angles in azimuth necessary to the pilot of an aircraft which on final approach does not deviate by an abnormal amount from the path defined by the non-visual aid.
  - (16) The lights shall be designed to provide guidance during both day and night in the most adverse conditions of visibility and ambient light for which it is intended that the system shall remain usable.

### **111. Precision Approach Category I Lighting System**

- (1) A precision approach category I lighting system shall consist of a row of lights on the extended centre line of the runway extending, wherever possible, over a distance of 500 m from the runway threshold with a row of lights forming a crossbar 30 m in length at a distance of 300 m from the runway threshold.
- (2) The lights forming the crossbar shall be as nearly as practicable in a horizontal straight line at right angles to, and bisected by, the line of the center line lights.
- (3) The lights of the crossbar shall be spaced so as to produce a linear effect, except that gap may be left on each side of the center line.
- (4) These gaps shall be kept to a minimum to meet local requirements and each shall not exceed 6 m.
- (5) The lights forming the center line shall be placed at longitudinal intervals of 30 m with the innermost light located 30 m from the threshold.
- (6) The system shall lie as nearly as practicable in the horizontal plane passing through the threshold, provided that:
  - (a) no object other than an ILS or MLS azimuth antenna shall protrude through the plane of the approach lights within a distance of 60 m from the centre line of the system; and
  - (b) no light other than a light located within the central part of a crossbar or a centre line barrette (not their extremities) shall be screened from an approaching aircraft.
- (7) Any ILS or MLS azimuth antenna protruding through the plane of the lights shall be treated as an obstacle and marked and lighted accordingly.
- (8) The center line and crossbar lights of a precision approach category I lighting system shall be fixed lights showing variable white.
- (9) Each center line light position shall consist of either:

- (a) a single light source in the innermost 300 m of the center line, two light sources in the central 300 m of the center line and three light sources in the outer 300 m of the center line to provide distance information; or
  - (b) a barrette.
- (10) Where the serviceability level of the approach lights specified as a maintenance objective can be demonstrated, each center line light position may consist of either:
- (a) a single light source; or
  - (b) a barrette.
- (11) The barrettes shall be at least 4 m in length and when they are composed of lights approximating to point sources, the lights shall be uniformly spaced at intervals of not more than 1.5 m.
- (12) Where the center line consists of barrettes as described in above, each barrette shall be supplemented by a flashing light, except where such lighting is considered unnecessary taking into account the characteristics of the system and the nature of the meteorological conditions.
- (13) Each flashing light shall be flashed twice a second in sequence, beginning with the outermost light and progressing toward the threshold to the innermost light of the system.
- (14) The design of the electrical circuit shall be such that these lights can be operated independently of the other lights of the approach lighting system.
- (15) Where the center line consists of lights as described in sub-regulation (9) above additional crossbars of lights to the crossbar provided at 300 m from the threshold shall be provided at 150 m, 450 m, 600 m and 750 m from the threshold.
- (16) The lights forming each crossbar shall be as nearly as practicable in a horizontal straight line at right angles to, and bisected by, the line of the center line lights.
- (17) The lights shall be spaced so as to produce a linear effect, except that gap may be left on each side of the center line.
- (18) These gaps shall be kept to a minimum to meet local requirements and each shall not exceed 6 m.
- (19) Where the additional crossbars are incorporated in the system, the outer ends of the crossbars shall lie on two straight lines that either are parallel to the line of the center line lights or converge to meet the runway center line 300 m from threshold.
- (20) The lights shall be in accordance with the specifications of the Fourth Schedule, Figure A2-1.

## **112. Precision Approach Category II and III Lighting System**

- (1) The approach lighting system shall consist of a row of lights on the extended centre line of the runway, extending, wherever possible, over a distance of 900 m from the runway threshold.

- (2) In addition, the system shall have two side rows of lights, extending 270 m from the threshold, and two crossbars, one at 150 m and one at 300 m from the threshold, all as shown in Figure 5-14.
- (3) Where the serviceability level of the approach lights specified as maintenance objectives it can be demonstrated, the system may have two side rows of lights, extending 240 m from the threshold, and two crossbars, one at 150 m and one at 300 m from the threshold, all as shown in Figure 5-15.
- (4) The lights forming the center line shall be placed at longitudinal intervals of 30 m with the innermost lights located 30 m from the threshold.
- (5) The lights forming the side rows shall be placed on each side of the center line, at a longitudinal spacing equal to that of the center line lights and with the first light located 30 m from the threshold.
- (6) Where the serviceability level of the approach lights specified as maintenance objectives above, can be demonstrated, lights forming the side rows may be placed on each side of the center line, at a longitudinal spacing of 60 m with the first light located 60 m from the threshold.
- (7) The lateral spacing (or gauge) between the innermost lights of the side rows shall be not less than 18 m nor more than 22.5 m, and preferably 18 m, but in any event shall be equal to that of the touchdown zone lights.
- (8) The crossbar provided at 150 m from the threshold shall fill in the gaps between the center line and side row lights.
- (9) The crossbar provided at 300 m from the threshold shall extend on both sides of the center line lights to a distance of 15 m from the center line.
- (10) Where the center line beyond a distance of 300 m from the threshold consists of lights as described above, additional crossbars of lights shall be provided at 450 m, 600 m and 750 m from the threshold.
- (11) Where the additional crossbars described in these regulations are incorporated in the system, the outer ends of these crossbars shall lie on two straight lines that either are parallel to the center line or converge to meet the runway center line 300 m from the threshold.

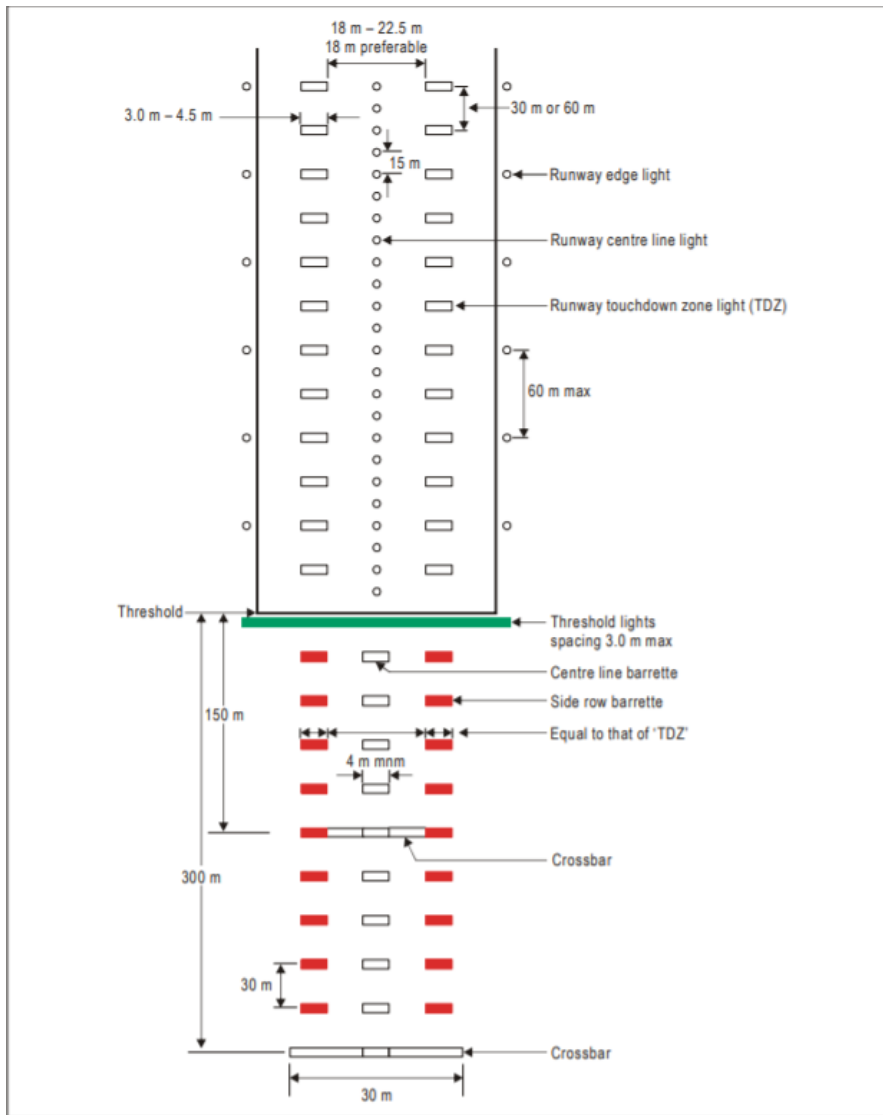

**Figure 5-14. Inner 300 m Approach and Runway Lighting for Precision Approach Runways, Categories II and II**

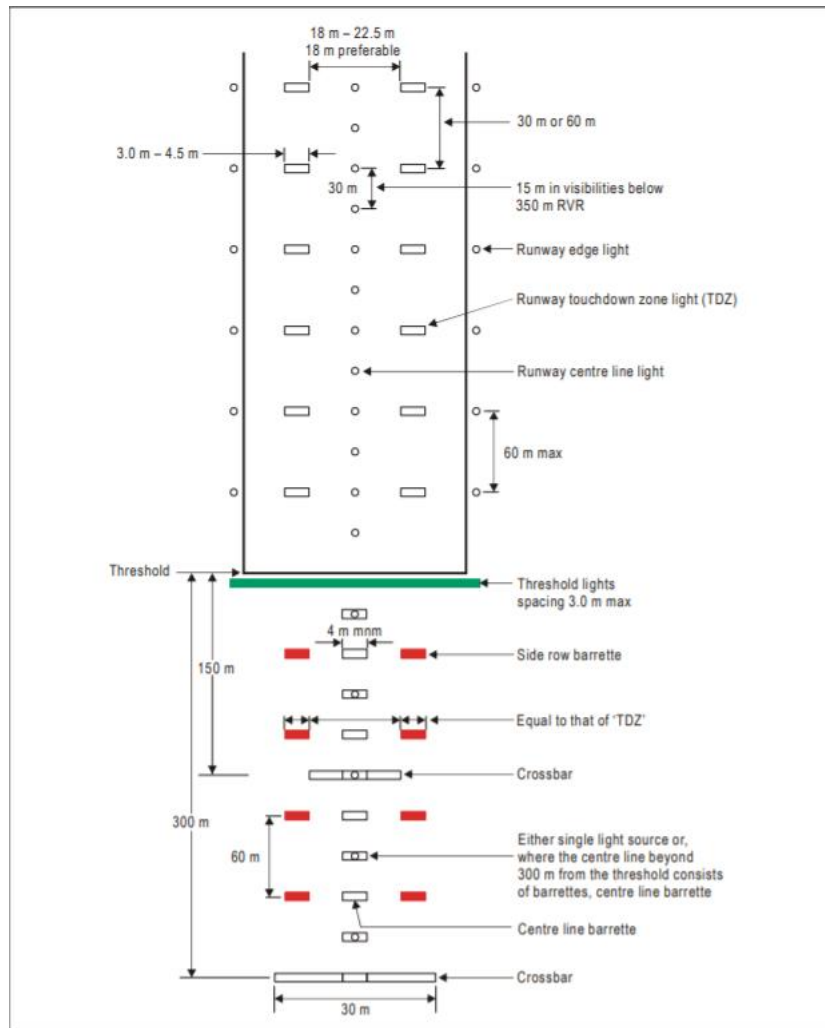

**Figure 5-15. Inner 300 m Approach and Runway Lighting for Precision Approach Runways, Categories II And III, Where the Serviceability Levels of The Lights Specified as Maintenance Objectives in Part XII Can Be Demonstrated**

- (12) The system shall lie as nearly as practicable in the horizontal plane passing through the threshold, provided that:
- (a) no object other than an ILS or MLS azimuth antenna shall protrude through the plane of the approach lights within a distance of 60 m from the centre line of the system; and
  - (b) no light other than a light located within the central part of a crossbar or a centre line barrette (not their extremities) shall be screened from an approaching aircraft.
- (13) Any ILS or MLS azimuth antenna protruding through the plane of the lights shall be treated as an obstacle and marked and lighted accordingly.
- (14) The center line of a precision approach category II and III lighting system for the first 300 m from the threshold shall consist of barrettes showing variable white, except that, where the threshold is displaced 300 m or more, the center line may consist of single light sources showing variable white.

- (15) Where the serviceability level of the approach lights specified as maintenance objectives in these regulations can be demonstrated, the center line of a precision approach category II and III lighting system for the first 300 m from the threshold may consist of either:
- (a) barrettes, where the center line beyond 300 m from the threshold consists of barrettes as above or;
  - (b) alternate single light sources and barrettes, where the center line beyond 300 m from the threshold consists of single light sources as described in above with the innermost single light source located 30 m and the innermost barrette located 60 m from the threshold; or
  - (c) single light sources where the threshold is displaced 300 m or more; all of which shall show variable white.
- (16) Beyond 300 m from the threshold each center line light position shall consist of either:
- (a) a barrette as used on the inner 300 m; or
  - (b) two light sources in the central 300 m of the centre line and three light sources in the outer 300 m of the centre line.
  - (c) all of which shall show variable white.
- (17) Where the serviceability level of the approach lights specified as maintenance objectives above can be demonstrated, beyond 300 m from the threshold each center line light position may consist of either:
- (a) a barrette; or
  - (b) a single light source;
  - (c) all of which shall show variable white.
- (18) The barrettes shall be at least 4 m in length and when composed of lights approximating to point sources, the lights shall be uniformly spaced at intervals of not more than 1.5 m.
- (19) Where the center line beyond 300 m from the threshold consists of barrettes as described above, each barrette beyond 300 m shall be supplemented by a flashing light, except where such lighting is considered unnecessary taking into account the characteristics of the system and the nature of the meteorological conditions.
- (20) Each flashing light as describe in these regulations shall be flashed twice a second in sequence, beginning with the outermost light and progressing toward the threshold to the innermost light of the system and the design of the electrical circuit shall be such that these lights can be operated independently of the other lights of the approach lighting system.
- (21) The side row shall consist of barrettes showing red and the length of a side row barrette and the spacing of its lights shall be equal to those of the touchdown zone light barrettes.
- (22) The lights forming the crossbars shall be fixed lights showing variable white and the lights shall be uniformly spaced at intervals of not more than 2.7 m.
- (23) The intensity of the red lights shall be compatible with the intensity of the white lights

- (24) The lights shall be in accordance with the specifications of Fourth Schedule, Figures A2-1 and A2-2.

### 113. Visual Approach Slope Indicator Systems

A visual approach slope indicator system shall be provided to serve the approach to a runway whether or not the runway is served by other visual approach aids or by non-visual aids, where one or more of the following conditions exist:

- (a) the runway is used by turbojet or other aeroplanes with similar approach guidance requirements;
- (b) the pilot of any type of aeroplane may have difficulty in judging the approach due to:
  - (i) inadequate visual guidance such as is experienced during an approach over water or featureless terrain by day or in the absence of sufficient extraneous lights in the approach area by night, or
  - (ii) misleading information such as is produced by deceptive surrounding terrain or runway slopes.
- (c) the presence of objects in the approach area may involve serious hazard where an aeroplane descends below the normal approach path, particularly where there are no non-visual or other visual aids to give warning of such objects;
- (d) physical conditions at either end of the runway present a serious hazard in the event of an aeroplane undershooting or overrunning the runway; and
- (e) terrain or prevalent meteorological conditions are such that the aeroplane may be subjected to unusual turbulence during approach.

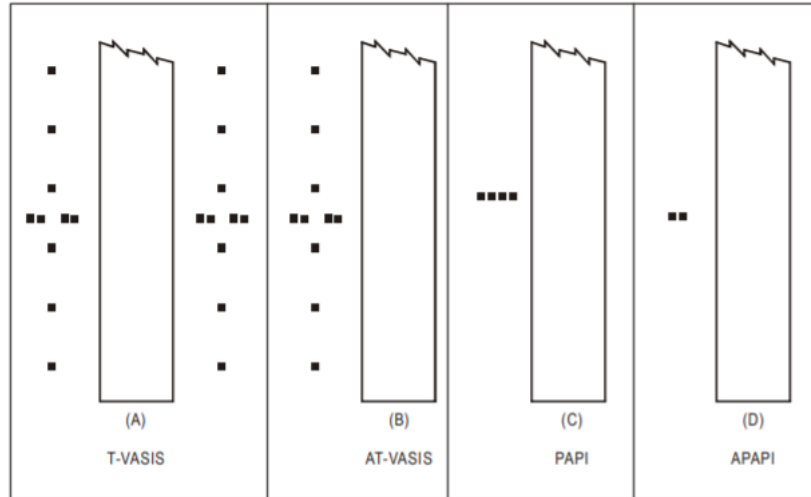

**Figure 5-16 – Visual Approach Slope Indicator systems**

### 114. Approach Slope and Elevation Setting of Light Beams

- (1) The standard visual approach slope indicator systems shall consist of a PAPI or APAPI system conforming to the specifications contained in these regulations as shown in figure 5-16 above;
- (2) PAPI, shall be provided where the code number is 3 or 4 when one or more of the conditions specified in Regulation 112 exist.

- (3) PAPI or APAPI shall be provided where the code number is 1 or 2 when one or more of the conditions specified in Regulation 112 exist.
- (4) Where a runway threshold is temporarily displaced from the normal position and one or more of the conditions specified in Regulation 112 exist, a PAPI should be provided except that where the code number is 1 or 2 an APAPI may be provided.
- (5) The elevation setting of the top of the red-light beams of the wing bar and fly-up light units shall be such that, during an approach, the pilot of an aeroplane to whom the wing bar and three fly-up light units are visible shall clear all objects in the approach area by a safe margin where any such light did not appear red.

#### **115. PAPI and APAPI**

- (1) The PAPI system shall consist of a wing bar of 4 sharp transition multi-lamp (or paired single lamp) units equally spaced and the system shall be located on the left side of the runway unless it is physically impracticable to do so.
- (2) The APAPI system shall consist of a wing bar of 2 sharp transition multi-lamp (or paired single lamp) units and the system shall be located on the left side of the runway unless it is physically impracticable to do so.
- (3) The wing bar of a PAPI shall be constructed and arranged in such a manner that a pilot making an approach shall:
  - (a) when on or close to the approach slope, see the two units nearest the runway as red and the two units farthest from the runway as white;
  - (b) when above the approach slope, see the one unit nearest the runway as red and the three units farthest from the runway as white; and when further above the approach slope, see all the units as white; and
  - (c) when below the approach slope, see the three units nearest the runway as red and the unit farthest from the runway as white; and when further below the approach slope, see all the units as red.
- (4) The wing bar of an APAPI shall be constructed and arranged in such a manner that a pilot making an approach shall:
  - (a) when on or close to the approach slope, see the unit nearer the runway as red and the unit farther from the runway as white;
  - (b) when above the approach slope, see both the units as white; and
  - (c) when below the approach slope, see both the units as red.
- (5) The light units shall be located as in the basic configuration illustrated in the figure below, subject to the installation tolerances given therein.
- (6) The units forming a wing bar shall be mounted so as to appear to the pilot of an approaching aircraft to be substantially in a horizontal line
- (7) The light units shall be mounted as low as possible and shall be frangible.

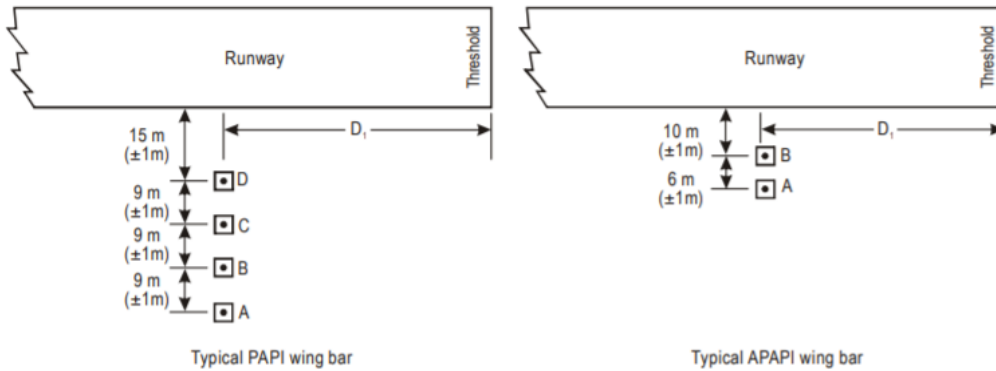

### INSTALLATION TOLERANCES

- (a) Where a PAPI or APAPI is installed on a runway not equipped with an ILS or MLS, the distance  $D_1$  shall be calculated to ensure that the lowest height at which a pilot shall see a correct approach path indication (Figure 5-20, angle B for a PAPI and angle A for an APAPI) provides the wheel clearance over the threshold specified in Table 5-2 for the most demanding amongst aeroplanes regularly using the runway.
- (b) Where a PAPI or APAPI is installed on a runway equipped with an ILS and/or MLS, the distance  $D_1$  shall be calculated to provide the optimum compatibility between the visual and non-visual aids for the range of eye-to-antenna heights of the aeroplanes regularly using the runway. The distance shall be equal to that between the threshold and the effective origin of the ILS glide path or MLS minimum glide path, as appropriate, plus a correction factor for the variation of eye to-antenna heights of the aeroplanes concerned. The correction factor is obtained by multiplying the average eye to-antenna height of those aeroplanes by the cotangent of the approach angle. However, the distance shall be such that in no case shall the wheel clearance over the threshold be lower than that specified in column (3) of Table 5-2.

Note: See Regulation 156 for specifications on aiming point marking. Guidance on the harmonization of PAPI, ILS and/or MLS signals is contained in the Aerodrome Design Manual (Doc 9157), Part 4.

- (d) Where a wheel clearance, greater than that specified in a) above is required for specific aircraft, this can be achieved by increasing  $D_1$ ;
- (e) Distance  $D_1$  shall be adjusted to compensate for differences in elevation between the lens centers of the light units and the threshold;
- (f) To ensure that units are mounted as low as possible and to allow for any transverse slope, small height adjustments of up to 5 cm between units are acceptable. A lateral gradient not greater than 1.25 per cent can be accepted provided it is uniformly applied across the units.
- (g) A spacing of 6 m ( $\pm 1$  m) between PAPI units should be used on code numbers 1 and 2. In such an event, the inner PAPI unit shall be located not less than 10 m ( $\pm 1$  m) from the runway edge. Note: Reducing the spacing between light units results in a reduction in usable range of the system; and
- (h) The lateral spacing between APAPI units may be increased to 9 m ( $\pm 1$  m) where greater range is required or later conversion to a full PAPI is anticipated. In the

latter case, the inner APAPI unit shall be located 15 m ( $\pm 1$  m) from the runway edge.

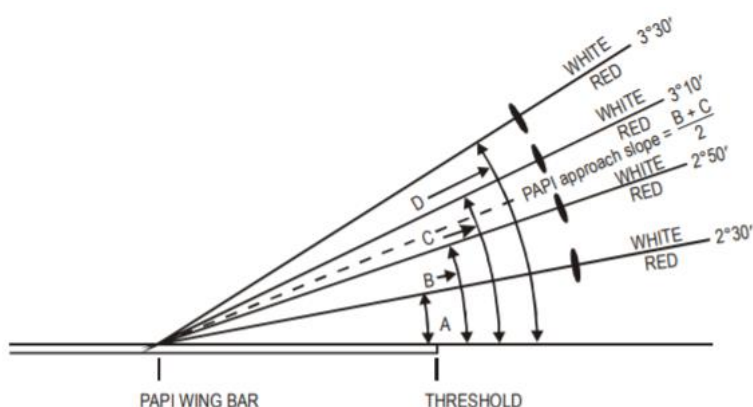

The height of the pilot's eye above the aircraft's ILS glide path/MLS antenna varies with the type of aeroplane and approach attitude. Harmonization of the PAPI signal and ILS glide path and/or MLS minimum glide path to a point closer to the threshold may be achieved by increasing the on-course sector from 20 to 30. The setting angles for a 3° glide slope would then be 2°25', 2°45', 3°15' and 3°35'.

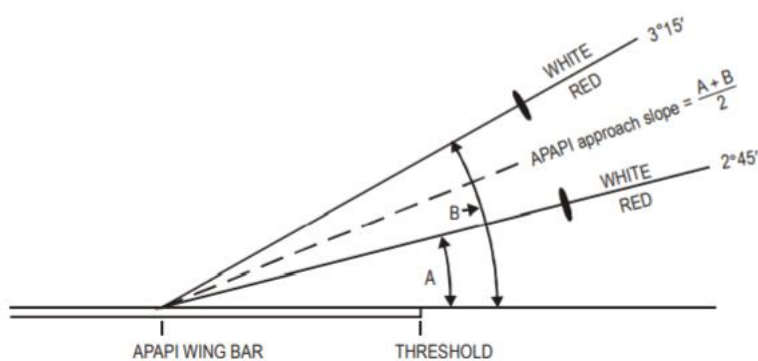

B — 3° APAPI ILLUSTRATED

Figure 5-20. Light Beams and Angle of Elevation Setting of PAPI and APAPI

Table 5-2 - Wheel Clearance Over Threshold for PAPI and APAPI

Eye-to-wheel height of aeroplane in the approach configuration <sup>a</sup> (1)	Required wheel clearance (metres) <sup>b</sup> (2)	Minimum wheel clearance (metres) <sup>c</sup> (3)
up to but not including 3 m	6	3 <sup>d</sup>
3 m up to but not including 5 m	9	4
5 m up to but not including 8 m	9	5
8 m up to but not including 14 m	9	6

- (8) In selecting the eye-to-wheel height group, only aeroplanes meant to use the system on a regular basis shall be considered. The most demanding amongst such aeroplanes shall determine the eye-to-wheel height group.
- (9) Where practicable the desired wheel clearances shown in column (2) shall be provided.
- (10) The wheel clearances shown in column (2) shall be provided, unless the threshold is displaced.
- (11) When a reduced wheel clearance is provided at a displaced threshold it shall be ensured that the corresponding desired wheel clearance specified in column (2) shall be available when an aeroplane at the top end of the eye-to-wheel height group chosen overflies the extremity of the runway.
- (12) This wheel clearance may be reduced to 1.5 m on runways used mainly by light-weight non-turbojet aeroplanes.
- (13) The system shall be suitable for both day and night operations.
- (14) The color transition from red to white in the vertical plane shall be such as to appear to an observer, at a distance of not less than 300 m, to occur within a vertical angle of not more than 3°
- (15) At full intensity the red light shall have a Y coordinate not exceeding 0.320.
- (16) The light intensity distribution of the light units shall be as shown in Fourth Schedule, Figure A2-23.
- (17) Suitable intensity control shall be provided so as to allow adjustment to meet the prevailing conditions and to avoid dazzling the pilot during approach and landing
- (18) Each light unit shall be capable of adjustment in elevation so that the lower limit of the white part of the beam may be fixed at any desired angle of elevation between 1°30' and at least 4°30' above the horizontal.
- (19) The light units shall be so designed those deposits of condensation, dirt, etc., on optically transmitting or reflecting surfaces shall interfere to the least possible extent with the light signals and shall not affect the contrast between the red and white signals and the elevation of the transition sector.

#### **116. Approach Slope and Elevation Setting of Light Units**

- (1) The approach slope as defined in Figure 5-20 shall be appropriate for use by the aeroplanes using the approach.
- (2) When the runway is equipped with an ILS and/or MLS, the siting and the angle of elevation of the light units shall be such that the visual approach slope conforms as closely as possible with the glide path of the ILS and/or the minimum glide path of the MLS, as appropriate.
- (3) The angle of elevation settings of the light units in a PAPI wing bar shall be such that, during an approach, the pilot of an aeroplane observing a signal of one white and three reds shall clear all objects in the approach area by a safe margin as per Table 5-2.

- (4) The angle of elevation settings of the light units in an APAPI wing bar shall be such that, during an approach, the pilot of an aeroplane observing the lowest on slope signal, i.e., one white and one red, shall clear all objects in the approach area by a safe margin as per Table 5-2.
- (5) The azimuth spread of the light beam shall be suitably restricted where an object located outside the obstacle protection surface of the PAPI or APAPI system, but within the lateral limits of its light beam, is found to extend above the plane of the obstacle protection surface and an aeronautical study indicates that the object may adversely affect the safety of operations.
- (6) The extent of the restriction shall be such that the object remains outside the confines of the light beam.
- (7) Where wing bars are installed on each side of the runway to provide roll guidance, corresponding units shall be set at the same angle so that the signals of each wing bar change symmetrically at the same time.

#### 117. Obstacle Protection Surface for PAPI and APAPI

- (1) An aerodrome operator shall establish an obstacle protection surface when it is intended to provide a visual approach slope indicator system.
- (2) The aerodrome operator shall ensure that, characteristics of the obstacle protection surface, i.e., origin, divergence, length and slope, correspond to those specified in the relevant column of Table 5-3 and in Figure 5-21.

**Table 5-3 Dimensions and slopes of the obstacle protection surface**

Surface dimensions	Runway type/code number							
	Non-instrument				Instrument			
	1	2	3	4	1	2	3	4
Length of inner edge	60 m	80 m	150 m	150 m	150 m	150 m	300 m	300 m
Distance from the visual approach slope indicator system <sup>e</sup>	D1+30 m	D1+60 m	D1+60 m	D1+60 m	D1+60 m	D1+60 m	D1+60 m	D1+60 m
Divergence (each side)	10%	10%	10%	10%	15%	15%	15%	15%
Total length	7 500 m	7 500 mb	15 000 m	15 000 m	7 500 m	7 500 mb	15 000 m	15 000 m
<i>Slope</i>								

(a) PAPI <sup>d</sup>	–	A–0.57°	A–0.57°	A–0.57°	A–0.57°	A–0.57°	A–0.57°	A–0.57°
(b) APAPI <sup>d</sup>	A–0.9°	A–0.9°	–	–	A–0.9°	A–0.9°	–	–

- (d) No slope has been specified where a system is unlikely to be used on runway type/code number indicated.
- (d) Angles as indicated in Figure 20.
- (e) D1 is the distance of the visual approach slope indicator system from threshold prior to any displacement to remedy object penetration of the OPS (refer Figure 19). The start of the OPS is fixed to the visual approach slope indicator system location, such that displacement of the PAPI results in an equal displacement of the start of the OPS. See Sub Regulation (5) (e).

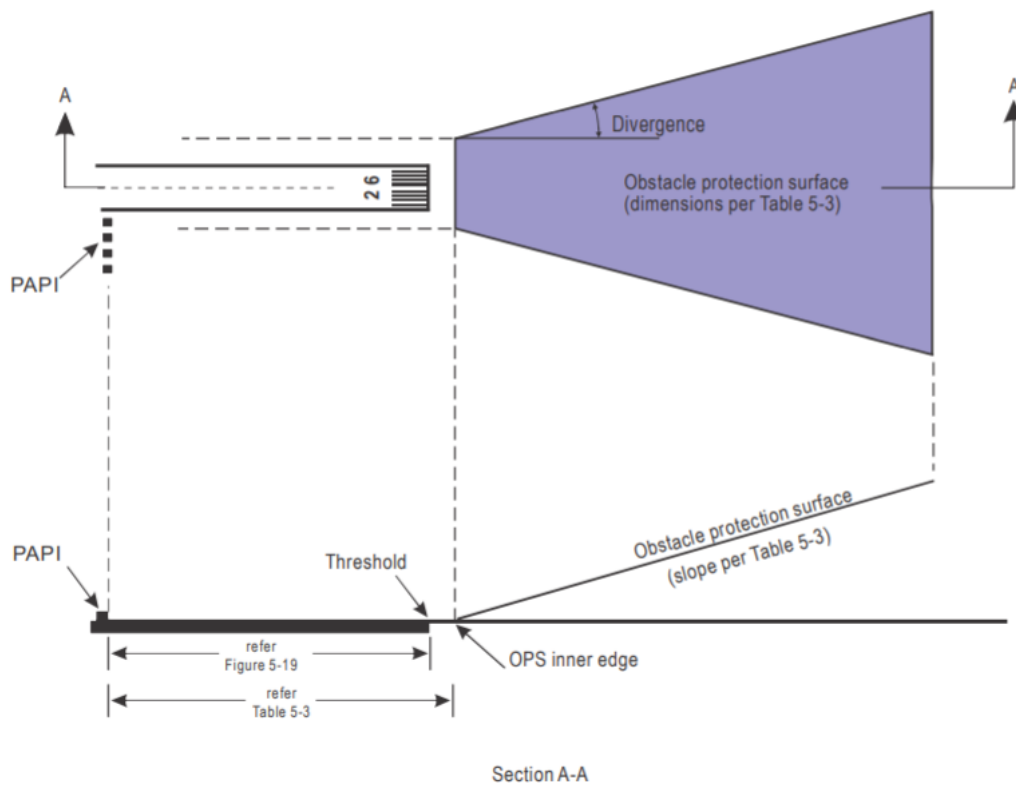

**Figure 5-21. Obstacle Protection Surface for Visual Approach Slope Indicator Systems.**

- (3) New objects or extensions of existing objects shall not be permitted above an obstacle protection surface except when, in the opinion of the Authority, the new object or extension shall be shielded by an existing immovable object.
- (4) Existing objects above an obstacle protection surface shall be removed except when, in the opinion of the Authority, the object is shielded by an existing immovable object, or after aeronautical study it is determined that the object shall not adversely affect the safety of operations of aeroplanes.

- (5) Where an aeronautical study indicates that an existing object extending above an obstacle protection surface may adversely affect the safety of operations of aeroplanes one or more of the following measures shall be taken:
  - (a) remove the object;
  - (b) suitably raise the approach slope of the system;
  - (c) reduce the azimuth spread of the system so that the object is outside the confines of the beam;
  - (d) displace the axis of the system and its associated obstacle protection surface by no more than 5°; and
  - (e) suitably displace the system upwind of the threshold such that the object no longer penetrates the OPS.

### **118. Circling Guidance Lights**

- (1) Circling guidance lights shall be provided when existing approach and runway lighting systems do not satisfactorily permit identification of the runway and/or approach area to a circling aircraft in the conditions for which it is intended the runway be used for circling approaches.
- (2) The location and number of circling guidance lights shall be adequate to enable a pilot, as appropriate, to:
  - (a) join the downwind leg or align and adjust the aircraft's track to the runway at a required distance from it and to distinguish the threshold in passing; and
  - (b) keep in sight the runway threshold and/or other features which shall make it possible to judge the turn on to base leg and final approach, taking into account the guidance provided by other visual aids.
- (3) Circling guidance lights shall consist of:
  - (a) lights indicating the extended centre line of the runway and/or parts of any approach lighting system; or
  - (b) lights indicating the position of the runway threshold; or
  - (c) lights indicating the direction or location of the runway; or
  - (d) or a combination of such lights as is appropriate to the runway under consideration.
- (4) Circling guidance lights shall be fixed or flashing lights of an intensity and beam spread adequate for the conditions of visibility and ambient light in which it is intended to make visual circling approaches.
- (5) The flashing lights shall be white, and the steady lights either white or gaseous discharge lights.
- (6) The lights shall be designed and be installed in such a manner that they shall not dazzle or confuse a pilot when approaching to land, taking off or taxiing.

### **119. Runway Lead-In Lighting Systems**

- (1) A runway lead-in lighting system shall be provided where it is desired to provide visual guidance along a specific approach path, for reasons such as avoiding hazardous terrain or for purposes of noise abatement.
- (2) A runway lead-in lighting system shall consist of groups of lights positioned so as to define the desired approach path and so that one group may be sighted from the preceding group.
- (3) The interval between adjacent groups shall not exceed approximately 1600 m.
- (4) A runway lead-in lighting system shall extend from a point as determined by the Authority, up to a point where the approach lighting system, where provided, or the runway or the runway lighting system is in view.
- (5) Each group of lights of a runway lead-in lighting system shall consist of at least three flashing lights in a linear or cluster configuration.
- (6) The system may be augmented by steady burning lights where such lights shall assist in identifying the system.
- (7) The flashing lights shall be white, and the steady burning lights gaseous discharge lights
- (8) Where practicable, the flashing lights in each group shall flash in sequence towards the runway.

#### **120. Runway Threshold Identification Lights**

- (1) Runway threshold identification lights shall be installed as follows:
  - (a) at the threshold of a non-precision approach runway when additional threshold conspicuity is necessary or where it is not practicable to provide other approach lighting aids; and
  - (b) where a runway threshold is permanently displaced from the runway extremity or temporarily displaced from the normal position and additional threshold conspicuity is necessary.
- (2) Runway threshold identification lights shall be located symmetrically about the runway center line, in line with the threshold and approximately 10 m outside each line of runway edge lights
- (3) Runway threshold identification lights shall be flashing white lights with a flash frequency between 60 and 120 per minute.
- (4) The lights shall be visible only in the direction of approach to the runway.

#### **121. Runway Edge Lights**

- (1) An aerodrome operator shall provide Runway edge lights for a runway intended for use at night or for a precision approach runway intended for use by day or night.
- (2) Runway edge lights shall be provided on a runway intended for take-off with an operating minimum below an RVR of the order of 800 m by day
- (3) Runway edge lights shall be placed along the full length of the runway and shall be in two parallel rows equidistant from the center line.

- (4) Runway edge lights shall be placed along the edges of the area declared for use as the runway or outside the edges of the area at a distance of not more than 3 m.
- (5) Where the width of the area which may be declared as runway exceeds 60 m, the distance between the rows of lights shall be determined taking into account the nature of the operations, the light distribution characteristics of the runway edge lights, and other visual aids serving the runway.
- (6) The lights shall be uniformly spaced in rows at intervals of not more than 60 m for an instrument runway, and at intervals of not more than 100 m for a non-instrument runway.
- (7) The lights on opposite sides of the runway axis shall be on lines at right angles to that axis.
- (8) At intersections of runways, lights may be spaced irregularly or omitted, provided that adequate guidance remains available to the pilot.
- (9) Runway edge lights shall be fixed lights showing variable white, except that:
  - (a) in the case of a displaced threshold, the lights between the beginning of the runway and the displaced threshold shall show red in the approach direction; and
  - (b) a section of the lights 600 m or one-third of the runway length, whichever is the less, at the remote end of the runway from the end at which the take-off run is started, may show yellow.
- (10) The runway edge lights shall show at all angles in azimuth necessary to provide guidance to a pilot landing or taking off in either direction and when the runway edge lights are intended to provide circling guidance, they shall show at all angles in azimuth
- (11) In all angles of azimuth required in Sub regulation (8) above, runway edge lights shall show at angles up to 15° above the horizontal with an intensity adequate for the conditions of visibility and ambient light in which use of the runway for take-off or landing is intended
- (12) In any case, the intensity shall be at least 50 cd except that at an aerodrome without extraneous lighting, the intensity of the lights may be reduced to not less than 25 cd to avoid dazzling the pilot.
- (13) Runway edge lights on a precision approach runway shall be in accordance with the Specification of Fourth Schedule, Figure A2-9 or A2-10.

## **122. Runway Threshold and Wing Bar Lights**

- (1) Runway threshold lights shall be provided for a runway equipped with runway edge lights except on a non-instrument or non-precision approach runway where the threshold is displaced and wing bar lights are provided.
- (2) When a threshold is at the extremity of a runway, the threshold lights shall be placed in a row at right angles to the runway axis as near to the extremity of the runway as possible and, in any case, not more than 3 m outside the extremity.

- (3) When a threshold is displaced from the extremity of a runway, threshold lights shall be placed in a row at right angles to the runway axis at the displaced threshold.
- (4) Threshold lighting shall consist of:
  - (a) on a non-instrument or non-precision approach runway, at least six lights;
  - (b) on a precision approach runway category I, at least the number of lights that shall be required where the lights were uniformly spaced at intervals of 3 m between the rows of runway edge lights; and
  - (c) on a precision approach runway category II or III, lights uniformly spaced between the rows of runway edge lights at intervals of not more than 3 m.
- (5) The lights prescribed in Sub regulation (4) (a) and (b) shall be either:
  - (a) equally spaced between the rows of runway edge lights; or
  - (b) Symmetrically disposed about the runway center line in two groups, with the lights uniformly spaced in each group and with a gap between the groups equal to the gauge of the touchdown zone marking or lighting, where such is provided, or otherwise not more than half the distance between the rows of runway edge lights.
- (6) Wing bar lights shall be provided on a precision approach runway when additional conspicuity is considered desirable.
- (7) Wing bar lights shall be provided on a non-instrument or non-precision approach runway where the threshold is displaced and runway threshold lights are required, but are not provided.
- (8) Wing bar lights shall be symmetrically disposed about the runway center line at the threshold in two groups, i.e., wing bars.
- (9) Each wing bar shall be formed by at least five lights extending at least 10 m outward from, and at right angles to, the line of the runway edge lights, with the innermost light of each wing bar in the line of the runway edge lights.
- (10) Runway threshold and wing bar lights shall be fixed unidirectional lights showing green in the direction of approach to the runway.
- (11) The intensity and beam spread of the lights shall be adequate for the conditions of visibility and ambient light in which use of the runway is intended.
- (12) Runway threshold lights on a precision approach runway shall be in accordance with the specifications of Fourth Schedule, Figure A2-3.
- (13) Threshold wing bar lights on a precision approach runway shall be in accordance with the specifications of Fourth Schedule, Figure A2-4.

### **123. Runway End Lights**

- (1) Runway end lights shall be provided for a runway equipped with runway edge lights and shall be in accordance with the specifications of Fourth Schedule Figure 5-22.
- (2) Runway end lights shall be placed on a line at right angles to the runway axis as near to the end of the runway as possible and, in any case, not more than 3 m outside the end.
- (3) Runway end lighting shall consist of at least six lights. The lights shall be either:

- (a) equally spaced between the rows of runway edge lights, or
  - (b) symmetrically disposed about the runway centre line in two groups with the lights uniformly spaced in each group and with a gap between the groups of not more than half the distance between the rows of runway edge lights.
- (4) For a precision approach runway category III, the spacing between runway end lights, except between the two innermost lights where a gap is used, shall not exceed 6 m.
  - (5) Runway end lights shall be fixed unidirectional lights showing red in the direction of the runway and the intensity.
  - (6) The intensity and beam spread of the lights shall be adequate for the conditions of visibility and ambient light in which use of the runway is intended.
  - (7) Runway end lights on a precision approach runway shall be in accordance with the specifications of Fourth Schedule, Figure A2-8.

#### **124. Runway Centre Line Lights**

- (1) Runway centre line lights shall be provided on a precision approach runway category II.
- (2) Runway enter line lights shall be provided on a precision approach runway category I, particularly when the runway is used by aircraft with high landing speeds or where the width between the runway edge lights is greater than 50 m.
- (3) Runway center line lights shall be provided on a runway intended to be used for take-off with an operating minimum below an RVR of the order of 400 m.
- (4) Runway center line lights shall be provided on a runway intended to be used for take-off with an operating minimum of an RVR of the order of 400 m or higher when used by aeroplanes with a very high take-off speed, particularly where the width between the runway edge lights is greater than 50 m.
- (5) Runway center line lights shall be located along the center line of the runway, except that the lights may be uniformly offset to the same side of the runway center line by not more than 60 cm where it is not practicable to locate them along the center line. The lights shall be located from the threshold to the end at longitudinal spacing of approximately 15 m.
- (6) Where the serviceability level of the runway center line lights specified as maintenance objectives in 290(4) or 290(13), as appropriate, can be demonstrated and the runway is intended for use in runway visual range conditions of 350 m or greater, the longitudinal spacing may be approximately 30 m.
- (7) Centre line guidance for take-off from the beginning of a runway to a displaced threshold shall be provided by:
  - (a) an approach lighting system where its characteristics and intensity settings afford the guidance required during take-off and it does not dazzle the pilot of an aircraft taking off;
  - (b) runway centre line lights; or
  - (c) barrettes of at least 3 m length and spaced at uniform intervals of 30 m, as shown in Figure 5-23, designed so that their photometric characteristics and intensity

setting afford the guidance required during take-off without dazzling the pilot of an aircraft taking off:

- (d) where necessary, provision shall be made to extinguish those centre line lights specified in b) or reset the intensity of the approach lighting system or barrettes when the runway is being used for landing and in no case shall only the single source runway centre line lights show from the beginning of the runway to a displaced threshold when the runway is being used for landing.
- (8) Runway center line lights shall be fixed lights showing variable white from the threshold to the point 900 m from the runway end; alternate red and variable white from 900 m to 300 m from the runway end; and red from 300 m to the runway end, except that for runways less than 1 800 m in length, the alternate red and variable white lights shall extend from the mid-point of the runway usable for landing to 300 m from the runway end.
- (9) Runway center line lights shall be in accordance with the specifications of Fourth Schedule, Figure A2-6 or A2-8.

#### **125. Runway Touchdown Zone Lights**

- (1) Touchdown zone lights shall be provided in the touchdown zone of a precision approach runway category II or III.
- (2) Touchdown zone lights shall extend from the threshold for a longitudinal distance of 900 m, except that, on runways less than 1 800 m in length, the system shall be shortened so that it does not extend beyond the midpoint of the runway.
- (3) The pattern shall be formed by pairs of barrettes symmetrically located about the runway centre line.
- (4) The lateral spacing between the innermost lights of a pair of barrettes shall be equal to the lateral spacing selected for the touchdown zone marking.
- (5) The longitudinal spacing between pairs of barrettes shall be either 30 m or 60 m.
- (6) A barrette shall be composed of at least three lights with a spacing between the lights of not more than 1.5m.
- (7) A barrette shall not be less than 3 m nor more than 4.5 m in length.
- (8) Touchdown zone lights shall be fixed uni-directional lights showing variable white.
- (9) Touchdown zone lights shall be in accordance with the specifications of Figure A2-5 in the Fourth Schedule to these regulations.

#### **126. Simple Touchdown Zone Lights**

- (1) Except where Touchdown Zone Lights are provided, at an aerodrome where the approach angle is greater than 3.5 degrees and/or the Landing Distance Available combined with other factors increases the risk of an overrun, Simple Touchdown Zone Lights shall be provided.
- (2) Simple Touchdown Zone Lights shall be a pair of lights located on each side of the runway centerline 0.3 meters beyond the upwind edge of the final Touchdown Zone Marking.

- (3) The lateral spacing between the inner lights of the two pairs of lights shall be equal to the lateral spacing selected for the Touchdown Zone Marking.
- (4) The spacing between the lights of the same pair shall not be more than 1.5 m or half the width of the touchdown zone marking, whichever is greater.
- (5) Where provided on a runway without TDZ markings, Simple Touchdown Zone lights shall be installed in such a position that provides the equivalent TDZ information.
- (6) Simple Touchdown Zone Lights shall be fixed unidirectional lights showing variable white, aligned so as to be visible to the pilot of a landing aeroplane in the direction of approach to the runway.
- (7) Simple touchdown zone lights shall be in accordance with the specifications in Fourth Schedule, Figure A2-5.

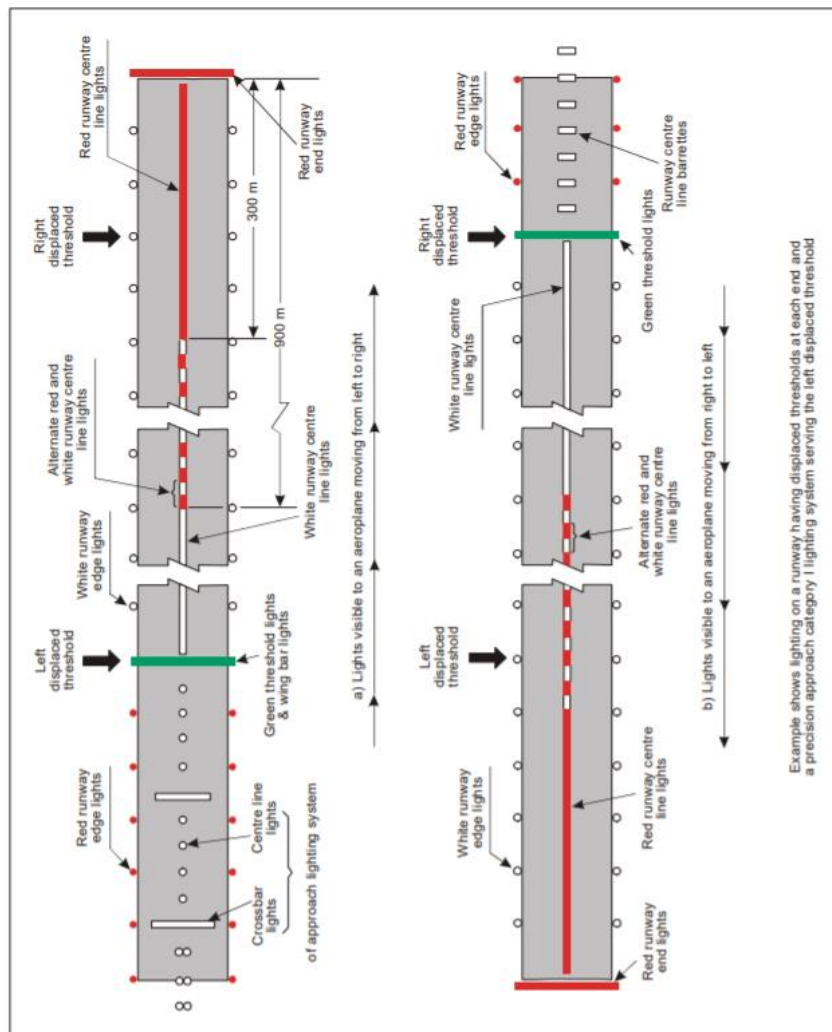

**Figure 5-23. Example Of Approach and Runway Lighting for Runway with Displaced Thresholds**

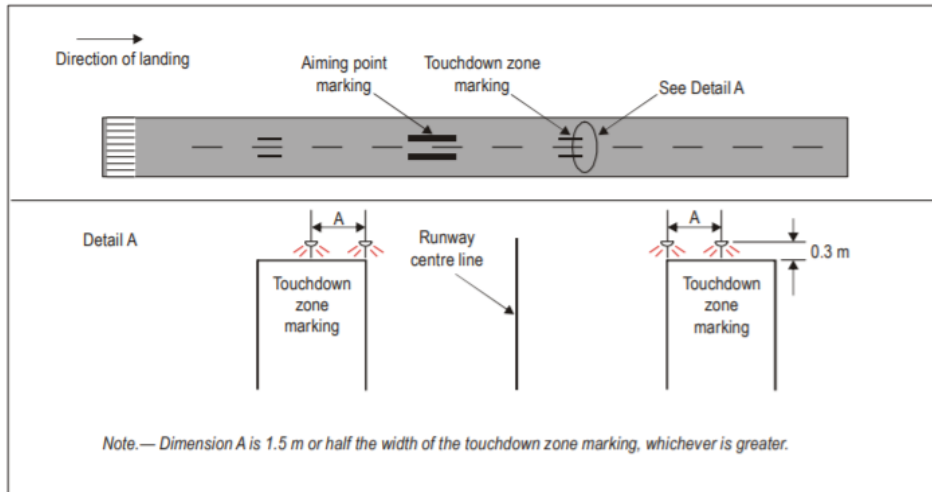

**Figure 5-24. Simple Touchdown Zone Lighting**

**127. Rapid Exit Taxiway Indicator Lights**

- (1) An aerodrome operator shall provide Rapid exit taxiway indicator lights on a runway intended for use in runway visual range condition less than value of 350 m and / or where the traffic density is heavy.
- (2) Rapid exit taxiway indicator lights shall not be displayed in the event of any lamp failure or other failure that prevents the display of the light pattern depicted in Figure 5-25, in full.

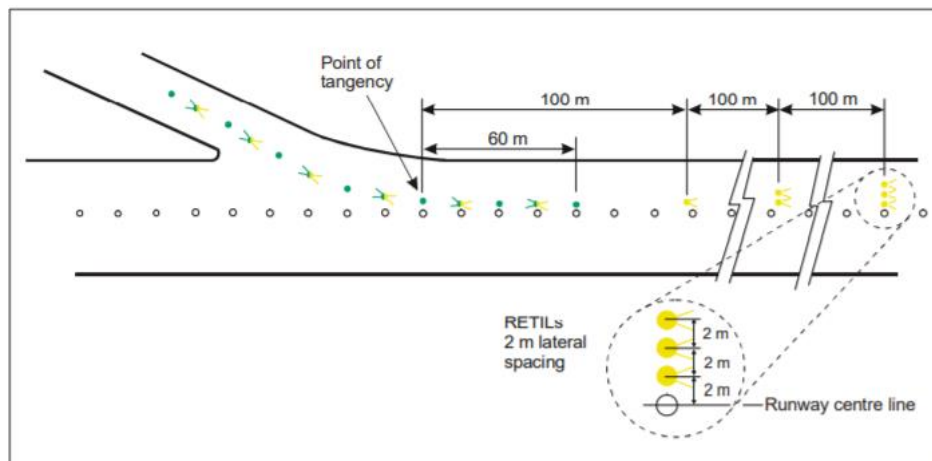

**Figure 5-25. Rapid Exit Taxiway Indicator Lights (RETILs)**

- (3) A set of rapid exit taxiway indicator lights shall be located on the runway on the same side of the runway center line as the associated rapid exit taxiway and in each set, the light shall be located 2 m apart and light nearest to the runway center line shall be displaced 2 m from the runway center line.
- (4) Where more than one rapid exit taxiway exits on a runway, the set of rapid exit taxiway indicator light for each exit shall not overlap when displayed.

- (5) Rapid exit taxiway indicator lights shall be fixed unidirectional yellow lights, aligned so as to be visible to the pilot of a landing aeroplane in the directional of approach to the runway.
- (6) Rapid exit taxiway indicator lights shall be in accordance with the specifications in Fourth Schedule, Figure A2-6 or Figure A2-7, as appropriate.
- (7) Rapid exit taxiway indicator lights shall be supplied with power on a separate circuit to other runway lighting so that they may be used when other lighting is switched off.

#### **128. Stop-Way Lights**

- (1) Stop-way lights shall be provided for a stop-way intended for use at night.
- (2) Stop-way lights shall be placed along the full length of the stop-way and shall be in two parallel rows that are equidistant from the center line and coincident with the rows of the runway edge lights.
- (3) Stop-way lights shall also be provided across the end of a stop-way on a line at right angles to the stop-way axis as near to the end of the stop-way as possible and, in any case, not more than 3 m outside the end.
- (4) Stop way lights shall be fixed unidirectional lights showing red in the direction of the runway.

#### **129. Taxiway Centre Line Lights**

- (1) An aerodrome operator shall provide Taxiway centre line lights on an exit taxiway and apron intended for use in runway visual range conditions less than a value of 350 m in such a manner as to provide continuous guidance between the runway centre line and aircraft stands, except that these lights need not be provided where the traffic density is light and taxiway edge lights and centre line marking provide adequate guidance.
- (2) The aerodrome operator shall provide Taxiway center line lights on a taxiway intended for use at night in runway visual range conditions of 350 m or greater, and particularly on complex taxiway intersections and exit taxiways, except that these lights need not be provided where the traffic density is light and taxiway edge lights and center line marking provide adequate guidance
- (3) The aerodrome operator shall provide Taxiway center line lights on an exit taxiway, taxiway and apron in all visibility conditions where specified as components of an advanced surface movement guidance and control system in such a manner as to provide continuous guidance between the runway center line and aircraft stands.
- (4) The aerodrome operator shall provide Taxiway center line lights on a runway forming part of a standard taxi-route and intended for taxiing in runway visual range conditions less than a value of 350 m, except that these lights need not be provided where the traffic density is light and taxiway edge lights and center line marking provide adequate guidance.
- (5) The aerodrome operator shall provide taxiway center line lights in all visibility conditions on a runway forming part of a standard taxi route where specified as components of an advanced surface movement guidance and control system.

- (6) Taxiway center line lights on a taxiway other than an exit taxiway and on a runway forming part of a standard taxi-route shall be fixed lights showing green with beam dimensions such that the light is visible only from aeroplanes on or in the vicinity of the taxiway
- (7) Taxiway center line lights on an exit taxiway shall be fixed lights.
- (8) Alternate taxiway center line lights shall show green and yellow from their beginning near the runway center line to the perimeter of the ILS/MLS critical/sensitive area or the lower edge of the inner transitional surface, whichever is farthest from the runway; and thereafter all lights shall show green.
- (9) The first light in the exit center line shall always show green and the light nearest to the perimeter shall always show yellow.
- (10) Where it is necessary to denote the proximity to a runway, taxiway center line lights shall be fixed lights showing alternating green and yellow from the perimeter of the ILS/MLS critical/sensitive area or the lower edge of the inner transitional surface, whichever is farthest from the runway, to the runway and continue alternating green and yellow until:
  - (a) their end point near the runway center line; or
  - (b) in the case of the taxiway center line lights crossing the runway, to the opposite perimeter of the ILS/MLS critical/sensitive area or the lower edge of the inner transitional surface, whichever is farthest from the runway.
- (11) Where higher intensities are required, from an operational point of view, taxiway centerline lights on rapid exit taxiways intended for use in runway visual range conditions less than a value of 350m shall be in accordance with the specifications prescribed by these regulations.
- (12) The number of levels of brilliancy settings for these lights shall be the same as that for the runway center line lights.
- (13) Where taxiway center line lights are specified as components of an advanced surface movement guidance and control system and where, from an operational point of view, higher intensities are required to maintain ground movements at a certain speed in very low visibilities or in bright daytime conditions, taxiway center line lights shall be in accordance with these Regulations.
- (14) Taxiway center line lights shall normally be located on the taxiway center line marking, except that they may be offset by not more than 30cm where it is not practicable to locate them on the marking.
- (15) Taxiway center line lights shall be in accordance with the specifications of:
  - (a) Fourth Schedule, Figure A2-12, A2-13, or A2-14, for taxiways intended for use in runway visual range conditions of less than a value of 350 m; and
  - (b) Fourth Schedule, Figure A2-15 or A2-16, for other taxiways.

### **130. Taxiway Centre Line Lights on A Straight Section of a Taxiway**

- (1) Taxiway centre line lights on a straight section of a taxiway shall be spaced at longitudinal intervals of not more than 30 m, except that:

- (a) larger intervals not exceeding 60 m may be used where, because of the prevailing meteorological conditions, adequate guidance is provided by such spacing;
  - (b) intervals less than 30 m shall be provided on short straight sections; and
  - (c) on a taxiway intended for use in RVR conditions of less than a value of 350 m, the longitudinal spacing shall not exceed 15 m.
  - (d) Taxiway centre line lights on a taxiway curve shall continue from the straight portion of the taxiway at a constant distance from the outside edge of the taxiway curve. The lights shall be spaced at intervals such that a clear indication of the curve is provided.
  - (e) on a taxiway intended for use in RVR conditions of less than a value of 350 m, the lights on a curve shall not exceed a spacing of 15 m and on a curve of less than 400 m radius the lights shall be spaced at intervals of not greater than 7.5 m; this spacing shall extend for 60 m before and after the curve.
- (2) Spacings on curves that have been found suitable for a taxiway intended for use in RVR conditions of 350 m or greater are:

Curve radius	Light spacing
up to 400 m	7.5 m
401 m to 899 m	15m
900 m or greater	30 m

**131. Taxiway Centre Line Lights on Rapid Exit Taxiways**

- (1) Taxiway centre line lights on a rapid exit taxiway shall commence at a point at least 60 m before the beginning of the taxiway centre line curve and continue beyond the end of the curve to a point on the centre line of the taxiway where an aeroplane can be expected to reach normal taxiing speed. The lights on that portion parallel to the runway centre line shall always be at least 60 cm from any row of runway centre line lights, as shown in Figure 5-27.
- (2) The lights shall be spaced at longitudinal intervals of not more than 15 m, except that, where runway center line lights are not provided, a greater interval not exceeding 30 m may be used.

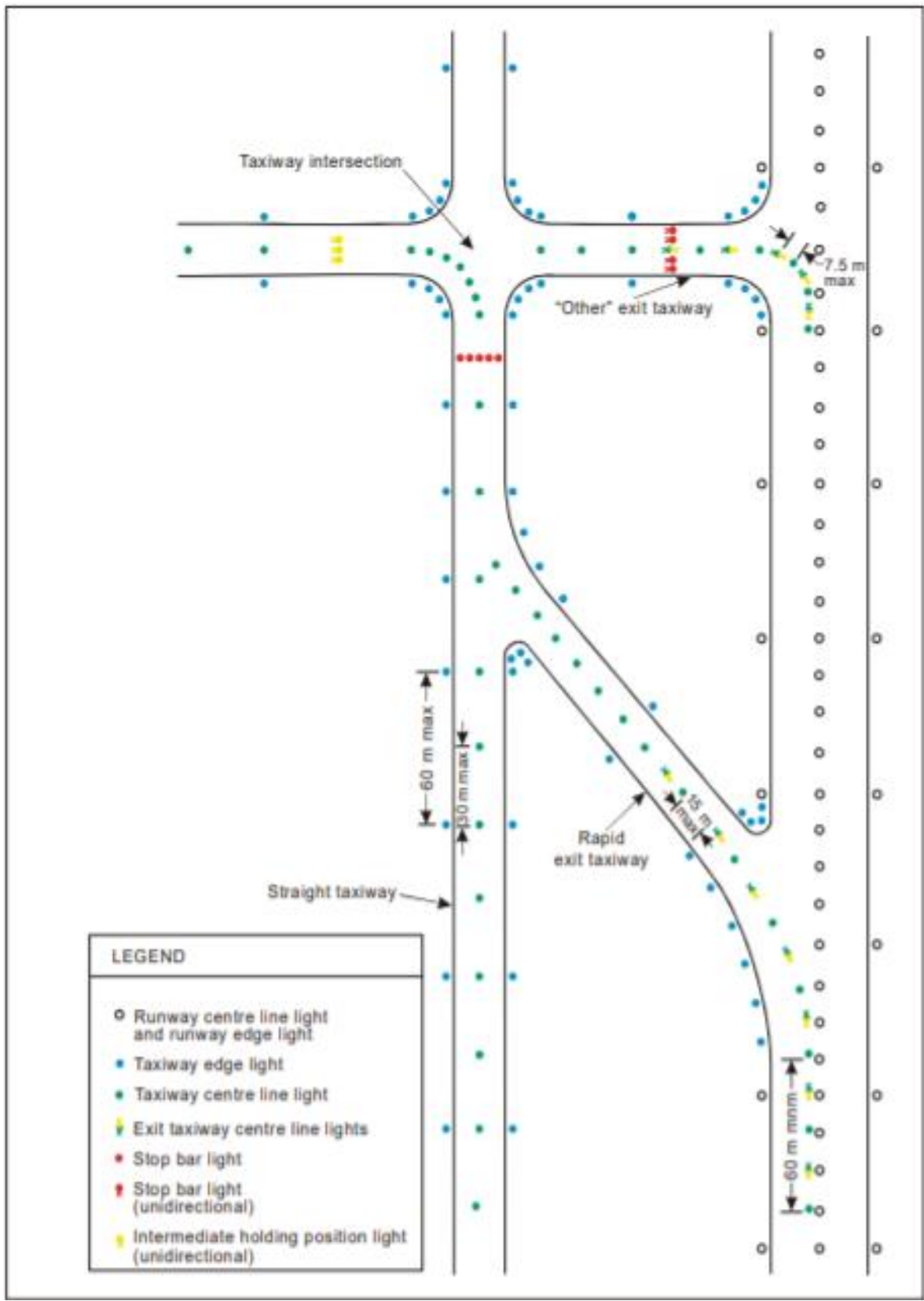
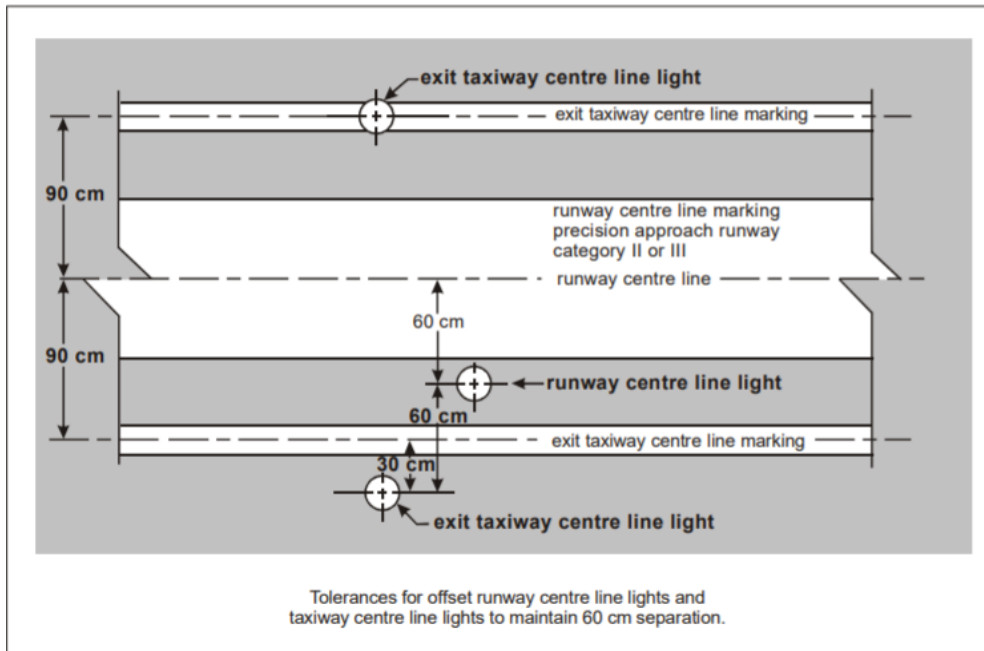

Figure 5-26. Taxiway Lighting



**Figure 5-27. Offset Runway and Taxiway Centre Line Lights**

**132. Taxiway Centre Line Lights on Other Exit Taxiways**

- (1) Taxiway centre line lights on exit taxiways other than rapid exit taxiways shall commence at the point where the taxiway centre line marking begins to curve from the runway centre line, and follow the curved taxiway centre line marking at least to the point where the marking leaves the runway and the first light shall be at least 60 cm from any row of runway centre line lights.
- (2) The lights shall be spaced at longitudinal intervals of not more than 7.5 m.

**133. Taxiway Centre Line Lights on Runways**

Taxiway centre line lights on a runway forming part of a standard taxi-route and intended for taxiing in runway visual range conditions less than a value of 350 m shall be spaced at longitudinal intervals not exceeding 15 m.

**134. Taxiway Edge Lights**

- (1) Taxiway edge lights shall be provided at the edges of a holding bay, apron, among others intended for use at night and on a taxiway not provided with taxiway centre line lights and intended for use at night, except that taxiway edge lights need not be provided where, considering the nature of the operations, adequate guidance can be achieved by surface illumination or other means.
- (2) Taxiway edge lights shall be provided on a runway forming part of a standard taxi-route and intended for taxiing at night where the runway is not provided with taxiway center line lights
- (3)
  - (a) Taxiway edge lights on a straight section of a taxiway and on a runway forming part of a standard taxi-route shall be spaced at uniform longitudinal intervals of not more than 60 m.

- (b) The lights on a curve shall be spaced at intervals less than 60 m so that a clear indication of the curve is provided.
- (4) Taxiway edge lights on a holding bay, apron, etc. shall be spaced at uniform longitudinal intervals of not more than 60 m.
- (5) Taxiway edge lights on a runway turn pad shall be spaced at uniform longitudinal interval of not more than 30m.
- (6) The lights shall be located as near as practicable to the edges of the taxiway, runway turn pad, holding bay, apron or runway, etc. or outside the edges at a distance of not more than 3 m.
- (7)
  - (a) Taxiway edge lights shall be fixed lights showing blue.
  - (b) The lights shall show up to at least 75° above the horizontal and at all angles in azimuth necessary to provide guidance to a pilot taxiing in either direction.
  - (c) At an intersection, exit or curve the lights shall be shielded as far as practicable so that they cannot be seen in angles of azimuth in which they may be confused with other lights.
- (8) Intensity of taxiway edge lights shall be at least 2 cd from 0° to 6° vertical, and 0.2 cd at any vertical angles between 6° and 75°.

### **135. Runway Turn Pad Lights**

- (1) Runway turn pad lights shall be provided for continuous guidance on a runway turn pad intended for use in runway visual range conditions less than a value of 350 m, to enable an aeroplane to complete a 180-degree turn and align with the runway centre line.
- (2) Runway turn pad lights shall be provided on a runway turn pad intended for use at night.
- (3) Runway turn pad lights shall normally be located on the runway turn pad marking, except that they may be offset by not more than 30 cm where it is not practicable to locate them on the marking.
- (4) Runway turn pad lights on a straight section of the runway turn pad marking shall be spaced at longitudinal intervals of not more than 15 m.
- (5) Runway turn pad lights on a curved section of the runway turn pad marking shall not exceed a spacing of 7.5 m.
- (6) Runway turn pad lights shall be unidirectional fixed lights showing green with beam dimensions such that the light is visible only from aeroplanes on or approaching the runway turn pad.
- (7) Runway turn pad lights shall be in accordance with the specifications of Fourth Schedule, Figure A2-13, A2-14 or A2-15, as appropriate.

### **136. Stop Bars**

- (1) A stop bar is intended to be controlled either manually or automatically by air traffic services.

- (2) A stop bar shall be provided at every runway-holding position serving a runway when it is intended that the runway shall be used in runway visual range conditions less than a value 550 m, except where:
  - (a) appropriate aids and procedures are available to assist in preventing inadvertent incursions of traffic onto the runway; or
  - (b) operational procedures exist to limit, in runway visual range conditions less than a value of 550 m, the number of:
    - (a) aircraft on the manoeuvring area to one at a time; and
    - (b) vehicles on the manoeuvring area to the essential minimum.
- (3) Where there is more than one stop bar associated with a taxiway/runway intersection, only one shall be illuminated at any given time.
- (4) A stop bar shall be provided at an intermediate holding position when it is desired to supplement markings with lights and to provide traffic control by visual means.
- (5) Stop bars shall be located across the taxiway at the point where it is desired that traffic stops and where the additional lights are provided, these lights shall be located not less than 3 m from the taxiway edge.
- (6) Stop bars shall consist of lights spaced at uniform intervals of no more than 3 m across the taxiway, showing red in the intended direction(s) of approach to the intersection or runway-holding position.
- (7) A pair of elevated lights shall be added to each end of the stop bar where the in-pavement stop bar lights might be obscured from a pilot's view, for example, by rain, or where a pilot may be required to stop the aircraft in a position so close to the lights that they are blocked from view by the structure of the aircraft.
- (8) Stop bars installed at a runway-holding position shall be unidirectional and shall show red in the direction of approach to the runway.
- (9) Where the additional lights specified by the Authority are provided, these lights shall have the same characteristics as the lights in the stop bar, but shall be visible to approaching aircraft up to the stop bar position.
- (10) The intensity in red light and beam spreads of stop bar lights shall be in accordance with the specifications in Fourth Schedule, Figures A2-12 through A2-16, as appropriate.
- (11) Where stop bars are specified as components of an advanced surface movement guidance and control system and where, from an operational point of view, higher intensities are required to maintain ground movements at a certain speed in very low visibilities or in bright daytime conditions, the intensity in red light and beam spreads of stop bar lights shall be in accordance with the specifications of Fourth Schedule, Figure A2-17, A2-18 or A2-19
- (12) Where a wide beam fixture is required, the intensity in red light and beam spreads of stop bar Lights shall be in accordance with the specifications of Fourth Schedule, Figure A2-17 or A2-19
- (13) The lighting circuit shall be designed so that:

- (a) stop bars located across entrance taxiways are selectively switchable;
- (b) stop bars located across taxiways intended to be used only as exit taxiways are switchable selectively or in groups;
- (c) when a stop bar is illuminated, any taxiway centre line lights installed beyond the stop bar shall be extinguished for a distance of at least 90 m; and
- (d) stop bars are interlocked with the taxiway centre line lights so that when the centre line lights beyond the stop bar are illuminated the stop bar is extinguished and vice versa.

**137. Intermediate Holding Position Lights**

- (1) Except where a stop bar has been installed, intermediate holding position lights shall be provided at an intermediate holding position intended for use in runway visual range conditions less than a value of 350 m.
- (2) Intermediate holding position lights shall be provided at an intermediate holding position where there is no need for stop-and-go signals as provided by a stop bar.
- (3) Intermediate holding position lights shall be located along the intermediate holding position marking at a distance of 0.3 m prior to the marking.
- (4)
  - (a) Intermediate holding position lights shall consist of three fixed unidirectional lights showing yellow in the direction of approach to the intermediate holding position with a light distribution similar to taxiway center line lights where provided.
  - (b) The lights shall be disposed symmetrically about and at right angle to the taxiway centre line, with individual lights spaced 1.5 m apart.

**138. Runway Guard Lights**

- (1) Runway guard lights, Configuration A, shall be provided at each taxiway/runway intersection associated with a runway intended for use in:
  - (a) runway visual range conditions less than a value of 550 m where a stop bar is not installed; and
  - (b) runway visual range conditions of values between 550 m and 1 200 m where the traffic density is heavy.
- (2) As part of runway incursion prevention measures, runway guard lights, Configuration A or B, shall be provided at each taxiway/runway intersection where runway incursion hot spots have been identified, and used under all weather conditions during day and night.
- (3) Configuration B runway guard lights shall not be collocated with a stop bar.
- (4) Where more than one runway-holding positions exist at a runway/taxiway intersection, only the set of runway guard lights associated with the operational runway-holding position shall be illuminated.
- (5) Runway guard lights, Configuration A, shall be located at each side of the taxiway on the holding side of the runway-holding position marking.
- (6) Runway guard lights, Configuration B, shall be located across the taxiway on the holding side of the runway-holding position marking.

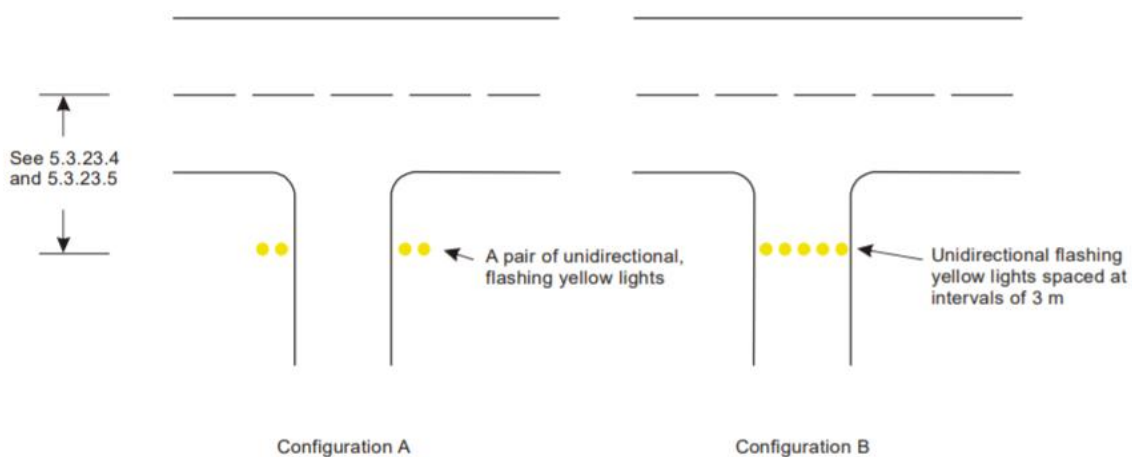

**Figure 5-29. Runway Guard Lights**

- (7) Runway guard lights, Configuration A, shall consist of two pairs of yellow lights.
- (8) Where there is a need to enhance the contrast between the on and off state of runway guard lights, Configuration A, intended for use during the day, a visor of sufficient size to prevent sunlight from entering the lens without interfering with the function of the fixture shall be located above each lamp.
- (9) Runway guard lights, Configuration B, shall consist of yellow lights spaced at intervals of 3 m across the taxiway.
- (10) The light beam shall be unidirectional and shall show yellow in the direction of approach to the runway-holding position.
- (11) The intensity in yellow light and beam spreads of lights of Configuration A shall be in accordance with the specifications in Fourth Schedule, Figure A2-24.
- (12) Where runway guard lights are intended for use during the day, the intensity in yellow light and beam spreads of lights of Configuration A shall be in accordance with the specifications in Fourth Schedule, Figure A2-25.
- (13) Where runway guard lights are specified as components of an advanced surface movement guidance and control system where higher light intensities are required, the intensity in yellow light and beam spreads of lights of Configuration A shall be in accordance with the specifications in Fourth Schedule, Figure A2-25.
- (14) The intensity in yellow light and beam spreads of lights of Configuration B shall be in accordance with the specifications in Fourth Schedule, Figure A2-12.
- (15) Where runway guard lights are intended for use during the day, the intensity in yellow light and beam spreads of lights of Configuration B shall be in accordance with the specifications in Fourth Schedule, Figure A2-20.
- (16) Where runway guard lights are specified as components of an advanced surface movement guidance and control system where higher light intensities are required, the intensity in yellow light and beam spreads of lights of Configuration B shall be in accordance with the specifications in Fourth Schedule, Figure A2-20.

- (17) The lights in each unit of Configuration A shall be illuminated alternately.
- (18) For Configuration B, adjacent lights shall be alternately illuminated and alternative lights shall be illuminated in unison.
- (19) The lights shall be illuminated between 30 and 60 cycles per minute and the light suppression and illumination periods shall be equal and opposite in each light.

**139. Apron Floodlighting**

- (1) Apron floodlighting shall be provided on an apron and on a designated isolated aircraft parking position intended to be used at night.
- (2)
  - (a) Apron floodlights shall be located so as to provide adequate illumination on all apron service areas, with a minimum of glare to pilots of aircraft in flight and on the ground, aerodrome and apron controllers, and personnel on the apron.
  - (b) The arrangement and aiming of floodlights shall be such that an aircraft stand receives light from two or more directions to minimize shadows.
- (3) The spectral distribution of apron floodlights shall be such that the colours used for aircraft marking connected with routine servicing, and for surface and obstacle marking, can be correctly identified.
- (4) The average illuminance shall be at least the following:

Aircraft stand:

  - (a) horizontal illuminance 20 lux with a uniformity ratio (average to minimum) of not more than 4 to 1; and
  - (b) vertical illuminance 20 lux at a height of 2 m above the apron in relevant directions. Other apron areas: and
  - (c) horizontal illuminance — 50 per cent of the average illuminance on the aircraft stands with a uniformity ratio (average to minimum) of not more than 4 to 1.

**140. Visual Docking Guidance System**

- (1) A visual docking guidance system shall be provided when it is intended to indicate, by a visual aid, the precise positioning of an aircraft on an aircraft stands and other alternative means, such as marshallers, are not practicable.
- (2) The system shall provide both azimuth and stopping guidance.
- (3) The azimuth guidance unit and the stopping position indicator shall be adequate for use in all weather, visibility, background lighting and pavement conditions for which the system is intended both by day and night, but shall not dazzle the pilot.
- (4) The azimuth guidance unit and the stopping position indicator shall be of a design such that:
  - (a) a clear indication of malfunction of either or both is available to the pilot; and
  - (b) they can be turned off.
- (5) The azimuth guidance unit and the stopping position indicator shall be located in such a way that there is continuity of guidance between the aircraft stand markings, the

aircraft stand manoeuvring guidance lights, where present, and the visual docking guidance system.

- (6) The accuracy of the system shall be adequate for the type of loading bridge and fixed aircraft servicing installations with which it is to be used.
- (7) The system shall be usable by all types of aircraft for which the aircraft stand is intended, preferably without selective operation.
- (8) Where selective operation is required to prepare the system for use by a particular type of aircraft, then the system shall provide an identification of the selected aircraft type to both the pilot and the system operator as a means of ensuring that the system has been set properly.

#### **141. Azimuth Guidance Unit**

- (1) The azimuth guidance unit shall be located on or close to the extension of the stand centre line ahead of the aircraft so that its signals are visible from the cockpit of an aircraft throughout the docking manoeuvre and aligned for use at least by the pilot occupying the left seat.
- (2) The azimuth guidance unit shall be aligned for use by the pilots occupying both the left and right seats.
- (3) The azimuth guidance unit shall provide unambiguous left/right guidance which enables the pilot to acquire and maintain the lead-in line without over controlling.
- (4) When azimuth guidance is indicated by colour change, green shall be used to identify the center line and red for deviations from the center line.

#### **142. Stopping Position Indicator**

- (1) The stopping position indicator shall be located in conjunction with, or sufficiently close to, the azimuth guidance unit so that a pilot can observe both the azimuth and stop signals without turning the head.
- (2) The stopping position indicator shall be usable at least by the pilot occupying the left seat.
- (3) The stopping position information provided by the indicator for a particular aircraft type shall account for the anticipated range of variations in pilot eye height and/or viewing angle.
- (4) The stopping position indicator shall show the stopping position for the aircraft for which guidance is being provided, and shall provide closing rate information to enable the pilot to gradually decelerate the aircraft to a full stop at the intended stopping position.
- (5) The stopping position indicator shall provide closing rate information over a distance of at least 10 m.
- (6) When stopping guidance is indicated by color change, green shall be used to show that the aircraft can proceed and red to show that the stop point has been reached, except that for a short distance prior to the stop point a third color may be used to warn that the stopping point is close.

### 143. Advanced Visual Docking Guidance System

- (1) An A-VDGS shall be provided where it is operationally desirable to confirm the correct aircraft type for which guidance is being provided and to indicate the stand centre line in use, where more than one is provided for:
  - (a) The A-VDGS shall be suitable for use by all types of aircraft for which the aircraft stand is intended.
  - (b) The A-VDGS shall be used only in conditions in which its operational performance is specified.
  - (c) The docking guidance information provided by an A-VDGS shall not conflict with that provided by a conventional visual docking guidance system on an aircraft stand where both types are provided and are in operational use. A method of indicating that the A-VDGS is not in operational use or is unserviceable shall be provided.
- (2) The A-VDGS shall be located such that unobstructed and unambiguous guidance is provided to the person responsible for, and persons assisting, the docking of the aircraft throughout the docking manoeuvre.
- (3) The A-VDGS shall be located such that unobstructed and unambiguous guidance is provided to the person responsible for, and persons assisting, the docking of the aircraft throughout the docking manoeuvre;
  - (a) an emergency stop indication;
  - (b) the aircraft type and model for which the guidance is provided;
  - (c) an indication of the lateral displacement of the aircraft relative to the stand centre line;
  - (d) the direction of azimuth correction needed to correct a displacement from the stand centre line;
  - (e) an indication of the distance to the stop position;
  - (f) an indication when the aircraft has reached the correct stopping position; and
  - (g) a warning indication where the aircraft goes beyond the appropriate stop position.
- (4) The A-VDGS shall be capable of providing docking guidance information for all aircraft taxi speeds encountered during the docking manoeuvre.
- (5) The time taken from the determination of the lateral displacement to its display shall not result in a deviation of the aircraft, when operated in normal conditions, from the stand Centre line greater than 1 m.
- (6) The information on displacement of the aircraft relative to the stand center line and distance to the stopping position, when displayed, shall be provided with the accuracy specified in Table 5-4.
- (7) Symbols and graphics used to depict guidance information shall be intuitively representative of the type of information provided.
- (8) Information on the lateral displacement of the aircraft relative to the stand Centre line shall be provided at least 25 m prior to the stop position.

- (9) Continuous closure distance and closure rate shall be provided from at least 15 m prior to the stop position.
- (10) Where provided, closure distance displayed in numerals shall be provided in meter integers to the stop position and displayed to 1 decimal place at least 3 m prior to the stop position.

**Table 5-4 A-VDGS Recommended Displacement Accuracy**

Guidance information	Maximum deviation at stop position (stop area)	Maximum deviation at 9m from stop position	Maximum deviation at 15m from stop position	Maximum deviation at 25m from stop position
Azimuth	±250 mm	±340 mm	±400 mm	±500 mm
Distance	±500 mm	±1000mm	±1300mm	Not specified

- (11) Throughout the docking manoeuvre, an appropriate means shall be provided on the A-VDGS to indicate the need to bring the aircraft to an immediate halt. In such an event, which includes a failure of the A-VDGS, no other information shall be displayed.
- (12) Provision to initiate an immediate halt to the docking procedure shall be made available to personnel responsible for the operational safety of the stand
- (13) The word “stops” in red characters shall be displayed when an immediate cessation of the docking manoeuvre is required.

**144. Aircraft Stand Manoeuvring Guidance Lights**

- (1) Aircraft stand manoeuvring guidance lights shall be provided to facilitate the positioning of an aircraft on an aircraft stands on a paved apron or on a de-icing/anti-icing facility intended for use in poor visibility conditions, unless adequate guidance is provided by other means.
- (2) Aircraft stand manoeuvring guidance lights shall be collocated with the aircraft stand markings.
- (3) Aircraft stand manoeuvring guidance lights, other than those indicating a stop position, shall be fixed yellow lights, visible throughout the segments within which they are intended to provide guidance.
- (4) The lights used to delineate lead-in, turning and lead-out lines shall be spaced at intervals of not more than 7.5 m on curves and 15 m on straight sections.
- (5) The lights indicating a stop position shall be fixed unidirectional lights showing red.
- (6) The intensity of the lights shall be adequate for the condition of visibility and ambient light in which the use of the aircraft stand is intended.

- (7) The lighting circuit shall be designed so that the lights may be switched on to indicate that an aircraft stand is to be used and switched off to indicate that it is not to be used.

#### **145. Road-Holding Position Light**

- (1) A road-holding position light shall be provided at each road-holding position serving a runway when it is intended that the runway shall be used in runway visual range conditions less than a value of 350 m.
- (2) A road-holding position light shall be provided at each road-holding position serving a runway when it is intended that the runway shall be used in runway visual range conditions of values between 350 m and 550 m.
- (3) A road-holding position light shall be located adjacent to the holding position marking 1.5 m ( $\pm 0.5$ m) from one edge of the road, i.e., left or right as appropriate to the local traffic regulations.
- (4) The road-holding position light shall comprise:
  - (a) a controllable red (stop)/green (go) traffic light; or
  - (b) a flashing-red light.
- (5) The road-holding position light beam shall be unidirectional and aligned so as to be visible to the driver of a vehicle approaching the holding position.
- (6) The intensity of the light beam shall be adequate for the conditions of visibility and ambient light in which the use of the holding position is intended, but shall not dazzle the driver.
- (7) The flash frequency of the flashing-red light shall be between 30 and 60 flashes per minute.

#### **146. No-Entry Bar**

- (1) A no-entry bar shall be provided across a taxiway which is intended to be used as an exit only taxiway to assist in preventing inadvertent access of traffic to that taxiway.
- (2) A no-entry bar shall be located across the taxiway at the end of an exit only taxiway where it is desired to prevent traffic from entering the taxiway in the wrong direction.
- (3) A no-entry bar shall be co-located with a no-entry sign and/or a no-entry marking.
- (4) A no-entry bar shall consist of unidirectional lights spaced at uniform intervals of no more than 3 m showing red in the intended direction(s) of approach to the runway.
- (5) A pair of elevated lights shall be added to each end of the no-entry bar where the in pavement no entry bar lights might be obscured from a pilot's view, for example, by snow or rain, or where a pilot may be required to stop the aircraft in a position so close to the lights that they are blocked from view by the structure of the aircraft.
- (6) The intensity in red light and beam spreads of no-entry bar lights shall be in accordance with the specifications in Fourth Schedule, Figures A2-12 through A2-16, as appropriate.
- (7) Where no-entry bars are specified as components of an advanced surface movement guidance and control system and where, from an operational point of view, higher

intensities are required to maintain ground movements at a certain speed in very low visibilities or in bright daytime conditions, the intensity in red light and beam spreads of no-entry bar lights shall be in accordance with the specifications of Fourth Schedule, Figure A2-17, A2-18 or A2-19.

- (8) Where a wide beam fixture is required, the intensity in red light and beam spreads of no-entry bar lights shall be in accordance with the specifications of Fourth Schedule, Figure A2-17 or A2-19.
- (9) Taxiway center line lights installed beyond the no-entry bar, looking in the direction of the runway, shall not be visible when viewed from the taxiway.

#### **147. Runway Status Lights**

- (1) Where provided, RELs shall be offset 0.6 m from the taxiway centre line on the opposite side to the taxiway centre line lights and begin 0.6 m before the runway-holding position extending to the edge of the runway. An additional single light shall be placed on the runway 0.6 m from the runway centre line and aligned with the last two taxiway RELs.
- (2) RELs shall consist of at least five light units and shall be spaced at a minimum of 3.8 m and a maximum of 15.2 m longitudinally, depending upon the taxiway length involved, except for a single light installed near the runway center line.
- (3) Where provided, THLs shall be offset 1.8 m on each side of the runway center line lights and extend, in pairs, starting at a point 115 m from the beginning of the runway and, thereafter, every 30 m for at least 450 m.
- (4) Where provided, RELs shall consist of a single line of fixed in pavement lights showing red in the direction of aircraft approaching the runway.
- (5) RELs shall illuminate as an array at each taxiway/runway intersection where they are installed less than two seconds after the system determines a warning is needed.
- (6) Intensity and beam spread of RELs shall be in accordance with the specifications of Fourth Schedule, Figures A2-12 and A2-14.
- (7) Where provided, THLs shall consist of two rows of fixed in pavement lights showing red facing the aircraft taking off.
- (8) THLs shall illuminate as an array on the runway less than two seconds after the system determines a warning is needed.
- (9) Intensity and beam spread of THLs shall be in accordance with the specifications of Fourth Schedule, Figure A2-26.
- (10) RELs and THLs shall be automated to the extent that the only control over each system shall be to disable one or both systems.

### **Signs**

#### **148. Provision of Signs**









- (1) Signs shall be provided to convey a mandatory instruction, information on a specific location or destination on a movement area or to provide other information to meet the requirements of these regulations.

- (2) A variable message sign shall be provided where:
  - (a) the instruction or information displayed on the sign is relevant only during a certain period of time; and
  - (b) there is a need for variable predetermined information to be displayed on the sign to meet the requirements of these regulations.
- (3) Signs shall be frangible. Those located near a runway or taxiway shall be sufficiently low to preserve clearance for propellers and the engine pods of jet aircraft. The installed height of the sign shall not exceed the dimension shown in the appropriate column of Table 5-5.
- (4) Signs shall be rectangular, as shown in Figures 5-30 and 5-31 with the longer side horizontal.
- (5) The only signs on the movement area utilizing red shall be mandatory instruction signs.
- (6) The inscriptions on a sign shall be in accordance with the provisions of the Fifth Schedule.

**Table 5-5 Location Distances for Taxiing Guidance Signs Including Runway Exit Signs**

Code number	Sign height (mm)			Perpendicular distance from defined taxiway pavement edge to near side of sign	Perpendicular distance from defined runway pavement edge to near side of sign
	Legend	Face (min.)	Installed (max)		
1 or 2	200	300	700	5-11 m	3-10 m
1 or 2	300	450	900	5-11 m	3-10 m
3 or 4	300	450	900	11-21 m	8-15 m
3 or 4	400	600	1 100	11-21 m	8-15 m

- (7) Signs shall be illuminated in accordance with the provisions of Third schedule when intended for use:
  - (a) in runway visual range conditions less than a value of 800 m; or
  - (b) at night in association with instrument runways; or
  - (c) at night in association with non-instrument runways where the code number is 3 or 4.

Runway designation of a runway extremity (Example)		Indicates a runway-holding position at a runway extremity
Runway designation of both extremities of a runway (Example)		Indicates a runway-holding position located at taxiway/runway intersection other than runway extremity
Category I hold position (Example)		Indicates a category I runway-holding position at the threshold of runway 25
Category II hold position (Example)		Indicates a category II runway-holding position at the threshold of runway 25
Category III hold position (Example)		Indicates a category III runway-holding position at the threshold of runway 25
Category II and III hold position (Example)		Indicates a joint category II and III runway-holding position at the threshold of runway 25
Category I, II and III hold position (Example)		Indicates a joint category I, II and III runway-holding position at the threshold of runway 25
NO ENTRY		Indicates that entry to an area is prohibited
Runway-holding position (Example)		Indicates a runway-holding position (in accordance with 3.12.3)

**Figure 5-30. Mandatory Instruction Signs**

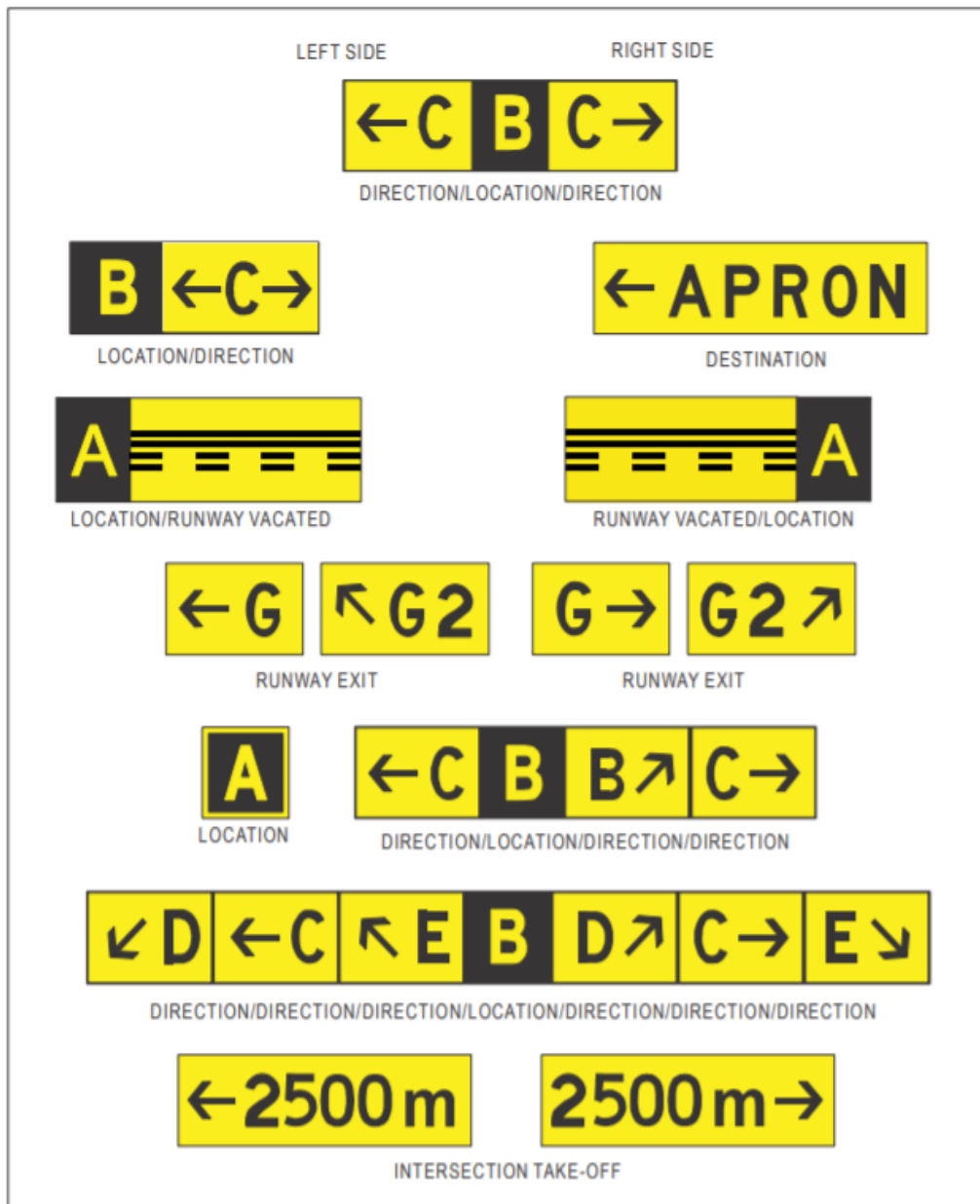
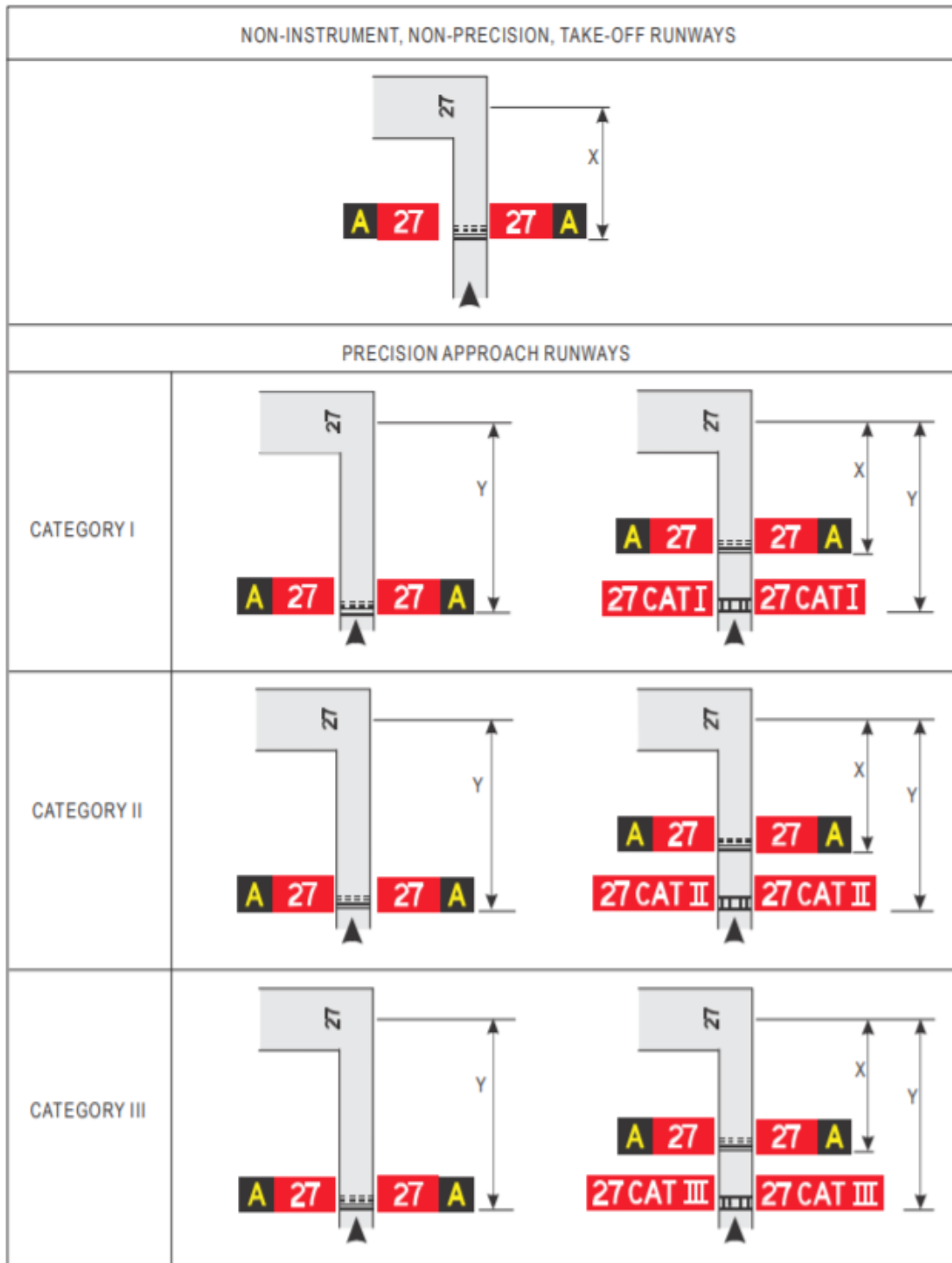

Figure 5-31. Information Signs

- (8) Signs shall be retro reflective and/or illuminated in accordance with the provisions of the Fifth Schedule when intended for use at night in association with non-instrument runways where the code number is 1 or 2.
- (9) A variable message sign shall show a blank face when not in use.
- (10) In case of failure, a variable message sign shall not provide information that could lead to unsafe action from a pilot or a vehicle driver.
- (11) The time interval to change from one message to another on a variable message sign shall be as short as practicable and shall not exceed 5 seconds.

**149. Mandatory Instruction Signs**

- (1) A mandatory instruction sign shall be provided to identify a location beyond which an aircraft taxiing or vehicle shall not proceed unless authorized by the aerodrome control tower.
- (2) Mandatory instruction signs shall include runway designation signs, category I, II or III holding position signs, runway-holding position signs, road-holding position signs and NO ENTRY signs.
- (3) A pattern "A" runway-holding position marking shall be supplemented at a taxiway/runway intersection or a runway/runway intersection with a runway designation sign.
- (4) A pattern "B" runway-holding position marking shall be supplemented with a category I, II or III holding position sign.
- (5) A pattern "A" runway-holding position marking at a runway-holding position established in accordance with Regulation 57(3) shall be supplemented with a runway-holding position sign.
- (6) A runway designation sign at a taxiway/runway intersection shall be supplemented with a location sign in the outboard (farthest from the taxiway) position, as appropriate.
- (7) A NO ENTRY sign shall be provided when entry into an area is prohibited.
- (8) A runway designation sign at a taxiway/runway intersection or a runway/runway intersection shall be located on each side of the runway-holding position marking facing the direction of approach to the runway.
- (9) A category I, II or III holding position sign shall be located on each side of the runway-holding position marking facing the direction of the approach to the critical area.
- (10) NO ENTRY sign shall be located at the beginning of the area to which entrance is prohibited on each side of the taxiway as viewed by the pilot.



Note: Distance X is established in accordance with Table 3-2. Distance Y is established at the edge of the ILS/MLS critical/sensitive area.

**Figure 5-32. Examples of Sign Positions at Taxiway/Runway Intersections**

- (11) A runway-holding position sign shall be located on each side of the runway-holding position established in accordance with Reg 57 (3) facing the approach to the obstacle limitation surface or ILS/MLS critical sensitive area, as appropriate.
- (12) Mandatory instruction sign shall consist of an inscription in white on a red background.

- (13) Where, owing to environmental or other factors, the conspicuity of the inscription on a mandatory instruction sign needs to be enhanced, the outside edge of the white inscription shall be supplemented by a black outline measuring 10 mm in width for runway code numbers 1 and 2, and 20 mm in width for runway code numbers 3 and 4.
- (14) The inscription on a runway designation sign shall consist of the runway designations of the intersecting runway properly oriented with respect to the viewing position of the sign, except that a runway designation sign installed in the vicinity of a runway extremity may show the runway designation of the concerned runway extremity only.
- (15) The inscription on a category I, II, III, joint II/III or joint I/II/III holding position sign shall consist of the runway designator followed by CAT I, CAT II, CAT III, CAT II/III or CAT I/II/III, as appropriate.
- (16) The inscription on a NO ENTRY sign shall be in accordance with Figure 26.
- (17) The inscription on a runway-holding position sign at a runway-holding position established in accordance with Regulation 57 (3) shall consist of the taxiway designation and a number.
- (18) Where installed, the inscriptions/symbol of Figure 5-32 shall be used.

#### **150. Information Sign**

- (1) An information sign shall be provided where there is an operational need to identify by a sign, a specific location, or routing direction or destination information.
- (2) Information signs shall include: direction signs, location signs, destination signs, runway exit signs, runway vacated signs and intersection take-off signs.
- (3) A runway exit sign shall be provided where there is an operational need to identify a runway exit.
- (4) A runway vacated sign shall be located at least on one side of the taxiway. The distance between the sign and the centre line of a runway shall be not less than the greater of the following:
  - (b) the distance between the center line of the runway and the perimeter of the ILS/MLS critical/sensitive area; or
  - (c) the distance between the center line of the runway and the lower edge of the inner transitional surface.
- (5) An intersection take-off sign shall be provided when there is an operational need to indicate the remaining take-off run available TORA for intersection take-offs.
- (6) Where necessary, a destination sign shall be provided to indicate the direction to a specific destination on the aerodrome, such as cargo area, general aviation, etc.
- (7) A combined location and direction sign shall be provided when it is intended to indicate routing information prior to a taxiway intersection.
- (8) A direction sign shall be provided when there is an operational need to identify the designation and direction of taxiways at an intersection.

- (9) A location sign shall be provided at an intermediate holding position.
- (10) A location sign shall be provided in conjunction with a runway designation sign except at a runway/runway intersection.
- (11) A location sign shall be provided in conjunction with a direction sign, except that it may be omitted where an aeronautical study indicates that it is not needed.
- (12) Where necessary, a location sign shall be provided to identify taxiways exiting an apron or taxiways beyond an intersection.
- (13) Where a taxiway ends at an intersection such as a “T” and it is necessary to identify this, a barricade, direction sign and/or other appropriate visual aid shall be used.
- (14) Except as specified in sub regulation (16) and (24) information signs shall, wherever practicable, be located on the left-hand side of the taxiway in accordance with Table 9.
- (15) At a taxiway intersection, information signs shall be located prior to the intersection and in line with the intermediate holding position marking. Where there is no intermediate holding position marking, the signs shall be installed at least 60 m from the centre line of the intersecting taxiway where the code number is 3 or 4, and at least 40 m where the code number is 1 or 2.
- (16) A runway exit sign shall be located on the same side of the runway as the exit is located (i.e. left or right) and positioned in accordance with Table 9.
- (17) A runway exit sign shall be located prior to the runway exit point in line with a position at least 60 m prior to the point of tangency where the code number is 3 or 4, and at least 30 m where the code number is 1 or 2.
- (18) A runway vacated sign shall be located at least on one side of the taxiway. The distance between the sign and the centre line of a runway shall be not less than the greater of the following:
- (19) Where provided in conjunction with a runway vacated sign, the taxiway location sign shall be positioned outboard of the runway vacated sign.
- (20) An intersection take-off sign shall be located at the left-hand side of the entry taxiway. The distance between the sign and the centre line of the runway shall be not less than 60 m where the code number is 3 or 4, and not less than 45 m where the code number is 1 or 2.
- (21) A taxiway location sign installed in conjunction with a runway designation sign shall be positioned outboard of the runway designation sign.
- (22) A destination sign shall not normally be collocated with a location or direction sign.
- (23) An information sign other than a location sign shall not be collocated with a mandatory instruction sign.
- (24) A direction sign, barricade and/or other appropriate visual aid used to identify a “T” intersection shall be located on the opposite side of the intersection facing the taxiway.

- (25) A location sign shall consist of an inscription in yellow on a black background and where it is a stand-alone sign shall have a yellow border.
- (26) The inscription on a runway exit sign shall consist of the designator of the exit taxiway and an arrow indicating the direction to follow.
- (27) The inscription on a runway vacated sign shall depict the pattern A runway-holding position marking as shown in Figure 27.
- (28) The inscription on an intersection take-off sign shall consist of a numerical message indicating the remaining take-off run available in metres plus an arrow, appropriately located and oriented, indicating the direction of the take-off as shown in Figure 27.
- (29) The inscription on a destination sign shall comprise an alpha, alphanumerical or numerical message identifying the destination plus an arrow indicating the direction to proceed as shown in Figure 5-31.
- (30) The inscription on a direction sign shall comprise an alpha or alphanumerical message identifying the taxiway(s) plus an arrow or arrows appropriately oriented as shown in Figure 5-31.
- (31) The inscription on a location sign shall comprise the designation of the location taxiway, runway or other pavement the aircraft is on or is entering and shall not contain arrows.
- (32) Where it is necessary to identify each of a series of intermediate holding positions on the same taxiway, the location sign shall consist of the taxiway designation and a number.
- (33) Where a location sign and direction signs are used in combination:
  - (a) all direction signs related to left turns shall be placed on the left side of the location sign, and all direction signs related to right turns shall be placed on the right side of the location sign, except that where the junction consists of one intersecting taxiway, the location sign may alternatively, be placed on the left-hand side;
  - (b) the direction signs shall be placed such that the direction of the arrows departs increasingly from the vertical with increasing deviation of the corresponding taxiway;
  - (d) an appropriate direction sign shall be placed next to the location sign where the direction of the location taxiway changes significantly beyond the intersection; and
  - (e) adjacent direction signs shall be delineated by a vertical black line as shown in Figure 5-31.
- (34) A taxiway shall be identified by a designator that is used only once on an aerodrome comprising a single letter, two letters or a combination of a letter or letters followed by a number.
- (35) When designating taxiways, use of words such as inner and outer shall be avoided

wherever possible.

- (36) When designating taxiways, the use of the letters I, O or X shall not be used to avoid confusion with the numerals 1, 0 and closed marking.
- (37) The use of numbers alone on the manoeuvring area shall be reserved for the designation of runways.
- (38) Apron stand designators shall not be the same as taxiway designators.

**151. VOR Aerodrome Checkpoint Sign**

- (1) When a VOR aerodrome checkpoint is established, it shall be indicated by a VOR aerodrome checkpoint marking and sign.
- (2) A VOR aerodrome checkpoint sign shall be located as near as possible to the checkpoint and so that the inscriptions are visible from the cockpit of an aircraft properly positioned on the VOR aerodrome checkpoint marking.
- (3) A VOR aerodrome checkpoint sign shall consist of an inscription in black on a yellow background.
- (4) The inscriptions on a VOR checkpoint sign shall be in accordance with one of the alternatives shown in Figure 28 in which:
  - (a) VOR is an abbreviation identifying this as a VOR checkpoint;
  - (b) 116.3 is an example of the radio frequency of the VOR concerned;
  - (c) 147° is an example of the VOR bearing, to the nearest degree, which shall be indicated at the VOR checkpoint; and
  - (d) 4.3 NM is an example of the distance in nautical miles to a DME collocated with the VOR concerned.

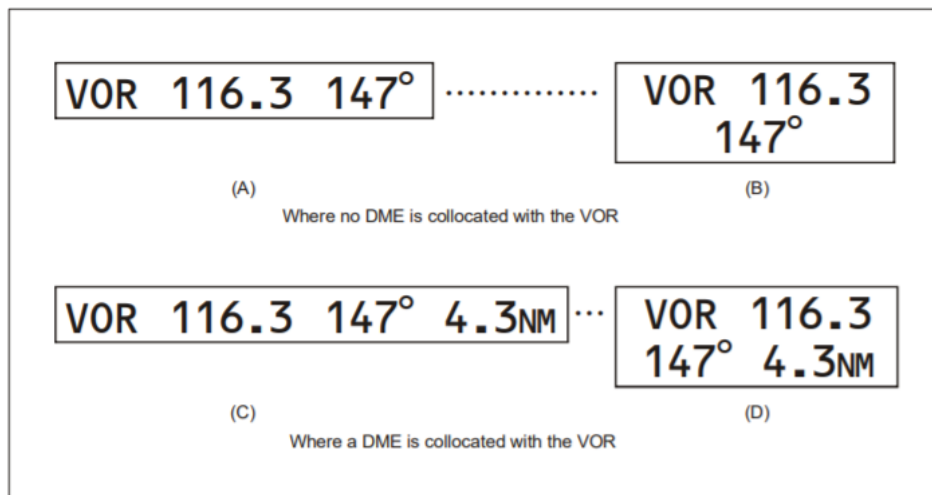

**Figure 5-33 VOR Aerodrome Checkpoint Sign**

**152. Aerodrome Identification Sign**

- (1) An aerodrome identification sign shall be provided at an aerodrome where there is insufficient alternative means of visual identification.
- (2) The aerodrome identification sign shall be placed on the aerodrome so as to be legible, in so far as is practicable, at all angles above the horizontal.
- (3) The aerodrome identification sign shall consist of the name of the aerodrome.
- (4) The colour selected for the sign shall give adequate conspicuity when viewed against its background.
- (5) The characters shall have a height of not less than 3 m.

**153. Aircraft Stand Identification Signs**

- (1) An aircraft stand identification marking shall be supplemented with an aircraft stand identification sign where feasible.
- (2) An aircraft stand identification sign shall be located so as to be clearly visible from the cockpit of an aircraft prior to entering the aircraft stand.
- (3) An aircraft stand identification sign shall consist of an inscription in black on a yellow background.

**154. Road-Holding Position Sign**

- (1) A road-holding position sign shall be provided at all road entrances to a runway.
- (2) The road-holding position sign shall be located 1.5 m from one edge of the road left or right as appropriate to the local traffic regulations at the holding position.
- (3) A road-holding position sign shall consist of an inscription in white on a red background.
- (4) The inscription on a road-holding position sign shall be in the national language, be in conformity with the local traffic regulations and include the following:
  - (a) requirement to stop; and
  - (b) where appropriate:

- (c) a requirement to obtain ATC clearance; and
- (d) location designator.
- (5) A road-holding position sign intended for night use shall be retro reflective or illuminated.

## **Markers**

### **155. Provision of Markers**

Where provided, markers shall be frangible. Those located near a runway or taxiway shall be sufficiently low to preserve clearance for propellers and for the engine pods of jet aircraft.

### **156. Paved Runways Edge Markers**

- (1) Markers shall be provided when the extent of an unpaved runway is not clearly indicated by the appearance of its surface compared with that of the surrounding ground.
- (2) Where runway lights are provided, the markers shall be incorporated in the light fixtures.
- (3) Where there are no lights, markers of flat rectangular or conical shape shall be placed so as to delimit the runway clearly.
- (4) The flat rectangular markers shall have a minimum size of 1 m by 3 m and shall be placed with their long dimension parallel to the runway Centre line.
- (5) The conical markers shall have a height not exceeding 50cm.

### **157. Stop Way Edge Markers**

- (1) Where provided, stop way edge markers shall be provided when the extent of a stop way is not clearly indicated by its appearance compared with that of the surrounding ground.
- (2) The stop way edge markers shall be sufficiently different from any runway edge markers used to ensure that the two types of markers cannot be confused.
- (3) Markers consisting of small vertical boards camouflaged on the reverse side, as viewed from the runway, have proved operationally acceptable.

### **158. Taxiway Edge Markers**

- (1) Where provided, taxiway edge markers shall be provided on a taxiway where the code number is 1 or 2 and taxiway Centre line or edge lights or taxiway Centre line markers are not provided.
- (2) Taxiway edge markers shall be installed at least at the same locations as would the taxiway edge lights had they been used.
- (3) A taxiway edge marker shall be retroreflective blue.
- (4) The marked surface as viewed by the pilot shall be a rectangle and shall have a minimum viewing area of 150 cm<sup>2</sup>.
- (5) Taxiway edge markers shall be frangible and their height shall be sufficiently low

to preserve clearance for propellers and for the engine pods of jet aircraft.

**159. Taxiway Centre Line Markers**

- (1) Where provided taxiway centre line markers shall be provided on a taxiway where there is a need to improve the guidance provided by the taxiway centre line marking.
- (2) A taxiway centre line marker shall be retroreflective green.
- (3) Taxiway centre line markers shall be so designed and fitted as to withstand being run over by the wheels of an aircraft without damage either to the aircraft or to the markers themselves.
- (4) The marked surface as viewed by the pilot shall be a rectangle and shall have a minimum viewing area of 20 cm<sup>2</sup>.

**160. Unpaved Taxiway Edge Markers**





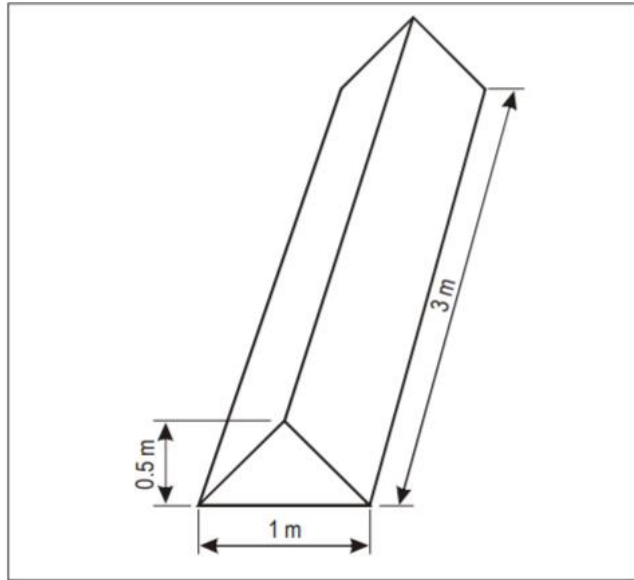

- (1) Where the extent of an unpaved taxiway is not clearly indicated by its appearance compared with that of the surrounding ground, markers shall be provided.
- (2) Where taxiway lights are provided, the markers shall be incorporated in the light fixtures.
- (3) Where there are no lights, markers of conical shape shall be placed so as to delimit the taxiway clearly

**161. Boundary Markers**

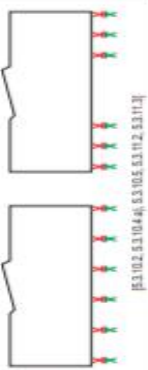
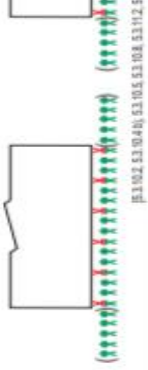
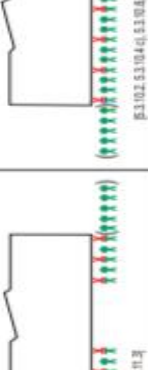
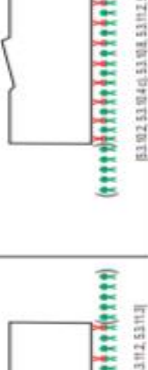
- (1) Boundary markers shall be provided at an aerodrome where the landing area has no runway.
- (2) Boundary markers shall be spaced along the boundary of the landing area at intervals of not more than 200 m, where the type shown in Figure 5-34 is used, or approximately 90 m, where the conical type is used with a marker at any corner.
- (3) Where provided, boundary markers shall be of a form similar to that shown in Figure 5-34 or in the form of a cone not less than 50 cm high and not less than 75 cm in diameter at the base.
- (4) The markers shall be coloured to contrast with the background against which they shall be seen.
- (5) A single colour, orange or red, or two contrasting colours, orange and white or alternatively red and white, shall be used, except where such colours merge with the background.

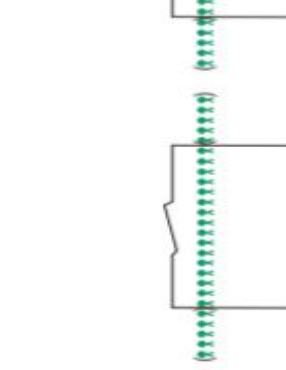
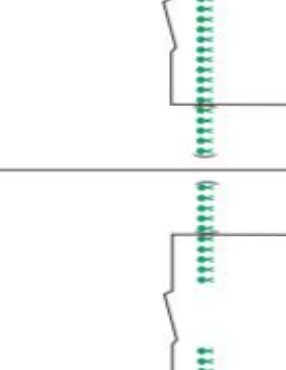
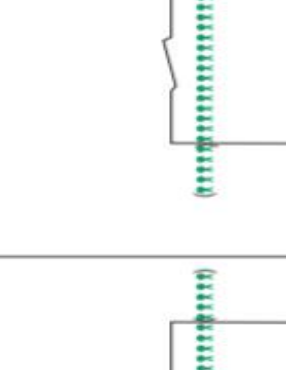
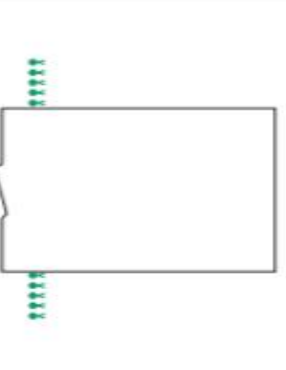
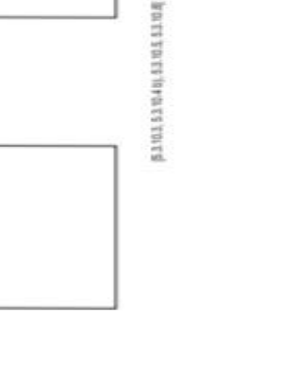

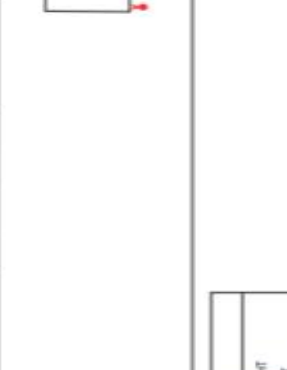
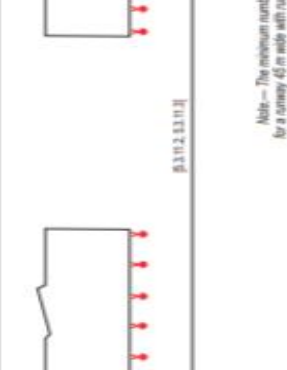
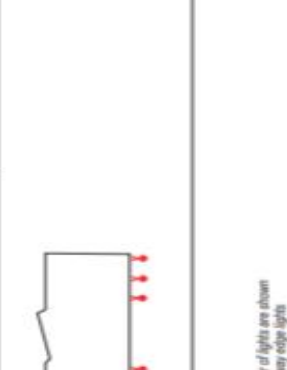
**Figure 5-34 Boundary Markers**

		RUNWAY TYPE			
CONDITION	LIGHTS	NON-INSTRUMENT AND NON-PRECISION APPROACH RUNWAYS	PRECISION APPROACH RUNWAYS CATEGORY I	PRECISION APPROACH RUNWAYS CATEGORY II	PRECISION APPROACH RUNWAYS CATEGORY III
THRESHOLD AT RUNWAY EXTREMITY	RUNWAY THRESHOLD AND RUNWAY END LIGHTS	 <p>[S.102, S.104, S.105, S.112, S.113]</p>	 <p>[S.102, S.104, S.105, S.108, S.112, S.113]</p>	 <p>[S.102, S.104, S.108, S.112, S.113]</p>	 <p>[S.102, S.104, S.108, S.112, S.113]</p>
THRESHOLD DISPLACED FROM RUNWAY EXTREMITY	RUNWAY THRESHOLD LIGHTS	 <p>[S.103, S.104, S.105, S.108]</p>	 <p>[S.103, S.104, S.105, S.108]</p>	 <p>[S.103, S.104, S.108]</p>	 <p>[S.103, S.104, S.108]</p>
	RUNWAY END LIGHTS	 <p>[S.103, S.104, S.105, S.108]</p>	 <p>[S.103, S.104, S.105, S.108]</p>	 <p>[S.103, S.104, S.108]</p>	 <p>[S.103, S.104, S.108]</p>
		 <p>[S.112, S.113]</p>	 <p>[S.112, S.113]</p>	 <p>[S.112, S.113]</p>	 <p>[S.112, S.113]</p>

LEGEND
 UNIDIRECTIONAL LIGHT
 BIDIRECTIONAL LIGHT
 CONDITIONAL RECOMMENDATION

Note – The minimum number of lights are shown for a runway 60m wide with runway edge lights installed at the edge.

Figure 5-22. Arrangement of runway threshold and runway end lights

**CHAPTER XIII**  
**VISUAL AIDS FOR DENOTING OBSTACLES**

**162. Provision of Visual Aids for Denoting Obstacles**

An aerodrome operator shall ensure that visual aids for denoting obstacles are duly provided and properly maintained so as to ensure the safe operation of aircraft at and around the aerodrome.

**163. Objects Within the Lateral Boundaries of the Obstacle Limitation Surfaces**

- (1) Vehicles and other mobile objects, excluding aircraft, on the movement area of an aerodrome shall be considered to be obstacles and shall be marked and, where the vehicles and aerodrome are used at night or in conditions of low visibility, they shall be lighted, except that aircraft servicing equipment and vehicles used only on aprons may be exempt.
- (2) Elevated aeronautical ground lights within the movement area shall be marked so as to be conspicuous by day and obstacle lights shall not be installed on elevated ground lights or signs in the movement area.
- (3) All obstacles within the distance specified in Table 2, column 11 or 12, from the centre line of a taxiway, an apron taxiway or aircraft stand taxi lane shall be marked and, where the taxiway, apron taxiway or aircraft stand taxi lane is used at night, lighted.
- (4) A fixed obstacle that extends above a take-off climb surface within 3000m of the inner edge of the take-off climb surface shall be marked and, where the runway is used at night, lighted, except that:
  - (a) the marking may be omitted when the obstacle is lighted by medium-intensity obstacle lights, Type A, by day and its height above the level of the surrounding ground does not exceed 150m;
  - (b) the marking may be omitted when the obstacle is lighted by high intensity obstacle lights by day; and
  - (c) lighting may be omitted where the obstacle is a lighthouse and an aeronautical study indicates the lighthouse light to be sufficient.
- (5) A fixed object, other than an obstacle, adjacent to a take-off climb surface shall be marked and, where the runway is used at night, lighted where such marking and lighting is considered necessary to ensure its avoidance, except that the marking may be omitted when:
  - (a) the object is lighted by medium-intensity obstacle lights, Type A, by day and its height above the level of the surrounding ground does not exceed 150m; or

- (b) the object is lighted by high-intensity obstacle lights by day.
- (6) A fixed obstacle that extends above an approach surface within 3 000 m of the inner edge or above a transitional surface shall be marked and, where the runway is used at night, lighted, except that:
  - (a) such marking and lighting may be omitted when the obstacle is shielded by another fixed obstacle;
  - (b) the marking may be omitted when the obstacle is lighted by medium-intensity obstacle lights, Type A, by day and its height above the level of the surrounding ground does not exceed 150 m;
  - (c) the marking may be omitted when the obstacle is lighted by high-intensity obstacle lights by day; and
  - (d) the lighting may be omitted where the obstacle is a lighthouse and an aeronautical study indicates the lighthouse light to be sufficient.
- (4) A fixed obstacle that extends above a horizontal surface shall be marked and, where the aerodrome is used at night, lighted except that:
  - (a) such marking and lighting may be omitted when:
    - (i) the obstacle is shielded by another obstacle; or
    - (ii) for a circuit extensively obstructed by immovable objects or terrain, procedures
    - (iii) have been established to ensure safe vertical clearance below prescribed flight
    - (iv) paths; and
    - (v) an aeronautical study shows the obstacle not to be of operational significance
  - (b) the marking may be omitted when the obstacle is lighted by medium-intensity obstacle lights, Type A, by day and its height above the level of the surrounding ground does not exceed 150m;
  - (c) the marking may be omitted when the obstacle is lighted by high intensity obstacle lights by day; and
  - (d) the lighting may be omitted where the obstacle is a lighthouse and an aeronautical study indicates the lighthouse light to be sufficient.
- (7) A fixed object that extends above an obstacle protection surface shall be marked and, where the runway is used at night, lighted.
- (8) Other objects inside the obstacle limitation surfaces shall be marked and/or lighted where an aeronautical study indicates that the object may constitute a hazard to aircraft and this includes objects adjacent to visual routes e.g., waterway or highway.
- (9) Overhead wires, cables, etc., crossing a river, waterway, valley or highway shall be marked and their supporting towers marked and lighted where an aeronautical study

indicated that the wires or cables may constitute a hazard to aircraft.

**164. Objects Outside the Lateral Boundaries of the Obstacle Limitation Surfaces**

- (1) Obstacles in areas beyond the limits of the obstacle limitation surfaces, which extend to a height of 150 m or more above ground elevation shall be considered as obstacles and shall be marked and lighted, except that the marking may be omitted when the obstacle is lighted by high-intensity obstacle lights by day.
- (2) Other objects outside the obstacle limitation surfaces shall be marked and/or lighted where an aeronautical study indicates that the object may constitute a hazard to aircraft including objects adjacent to visual routes such as waterways, and highways.
- (3) Overhead wires or cables, crossing a river, waterway, valley or highway shall be marked and their supporting towers marked and lighted where an aeronautical study indicates that the wires or cables may constitute a hazard to aircraft.

**165. Marking and Lighting of Objects**

- (1) The presence of objects which must be lighted, in accordance with these regulations shall be indicated by low-, medium- or high-intensity lights, or a combination of such lights.
- (2) Low-intensity obstacle lights, Types A B, C and D, medium-intensity obstacle lights, Types A, B and C, high-intensity obstacle lights Type A and B, shall be in accordance with the specifications in Table 4 and the seventh schedule.
- (3) Pursuant to sub-regulations (1) and (2):
  - (a) The number and arrangement of low-, medium- or high-intensity obstacle lights at each level to be marked shall be such that the object is indicated from every angle in azimuth;
  - (b) Where a light is shielded in any direction by another part of the object, or by an adjacent object, additional lights shall be provided on that adjacent object or the part of the object that is shielding the light, in such a way as to retain the general definition of the object to be lighted; and
  - (c) Where the shielded light does not contribute to the definition of the object to be lighted, it may be omitted.

**166. Marking and Lighting of Mobile Objects**

- (1) All mobile objects to be marked shall be colourer or display flags.
- (2) When mobile objects are marked by colour, a single conspicuous colour, preferably red or yellowish green for emergency vehicles and yellow for service vehicles, shall be used.
- (3) Flags used to mark mobile objects shall be displayed around, on top of, or around the highest edge of the object and shall not increase the hazard presented by the object they

mark.

- (4) Pursuant to sub-regulations (1) and (2):
  - (a) Flags used to mark mobile objects shall not be less than 0.9 m on each side and shall consist of a chequered pattern, each square having sides of not less than 0.3m.
  - (b) The colors of the pattern shall contrast each with the other and with the background against which they shall be seen.
  - (c) Orange and white or alternatively red and white shall be used, except where such colors merge with the background;
- (5) Low-intensity obstacle lights, Type C, shall be displayed on vehicles and other mobile objects excluding aircraft.
- (6) Low-intensity obstacle lights, Type C, displayed on vehicles associated with emergency or security shall be flashing-blue and those displayed on other vehicles shall be flashing-yellow.
- (7) Low-intensity obstacle lights, Type D, shall be displayed on follow-me vehicles.
- (8) Low-intensity obstacle lights on objects with limited mobility such as aerobridges shall be fixed-red, and as a minimum be in accordance with the specifications for low-intensity obstacle lights, Type A, in Table 4 and the intensity of the lights shall be sufficient to ensure compacity considering the intensity of the adjacent lights and the general levels of illumination against which they would normally be viewed.

**Table 4. Characteristics of Obstacle Lights**

1	2	3	4	5	6	7
Light Type	Colour	Signal type / (flash rate)	Peak intensity (cd) at given background luminance (b)			Light Distribution Table
			Day (50-100 cd/m <sup>2</sup> )	Twilight (50-100 cd/m <sup>2</sup> )	Night (Below 50 cd/m <sup>2</sup> )	
Low-intensity, Type A (fixed obstacle)	Red	Fixed	N/A	N/A	10	Table 5
Low-intensity, Type B (fixed obstacle)	Red	Fixed	N/A	N/A	32	Table 5
Low-intensity, Type C (mobile obstacle)	Yellow/Blue (a)	Flashing (60-90fp/m)	N/A	N/A	40	Table 5
Low-intensity, Type D (follow-me vehicle)	Yellow	Flashing (60-90fp/m)	N/A	N/A	200	Table 5

Medium-intensity, Type A	White	Flashing (20-60fp m)	20000	20000	2000	Table 6
Medium - intensity, Type B	Red	Flashing (20-60fp m)	N/A	N/A	2000	Table 6
Medium - intensity, Type C	Red	Fixed	N/A	N/A	2000	Table 6
High-intensity, Type A	White	Flashing (40-60fp m)	20000	20000	2000	Table 6

**Table 5. Light Distribution for Low-Intensity Obstacle Lights**

	Minimum intensity (a)	Maximum intensity (a)	Vertical beam spread (f)	
			Minimum beam spread	Intensity
Type A	10 cd (b)	N/A	10°	5 cd
Type A	32 cd (b)	N/A	10°	16 cd
Type A	40 cd (b)	400 cd	12° (d)	20 cd
Type A	200 cd (b)	400 cd	N/A (e)	N/A

Note: This table does not include recommended horizontal beam spreads. Therefore, the number of lights needed to meet this requirement shall depend on the horizontal beam spreads of each light as well as the shape of the obstacle. Thus, with narrower beam spreads, more lights shall be required.

- (a) 360° horizontal. For flashing lights, the intensity is read into effective intensity.
- (b) Between 2 and 10° vertical. Elevation vertical angles are referenced to the horizontal when the light is levelled.
- (c) Between 2 and 20° vertical. Elevation vertical angles are referenced to the horizontal when the light is levelled.
- (d) Peak intensity shall be located at approximately 2.5° vertical.
- (e) Peak intensity shall be located at approximately 17° vertical.
- (f) Beam spread is defined as the angle between the horizontal plane and the directions for which the intensity exceeds that mentioned in the “intensity” column.

**Table 6. Light Distribution for Medium-And High-Intensity Obstacle Lights According to Benchmark Intensities of Table 4**

Benchmark intensity	Minimum				Recommendations			
	Vertical elevation angle (b)		Vertical beam spread (c)	Intensity	Vertical elevation angle (b)			Vertical beam spread (c)
	0°	1°			0°	1°	10°	
	Minimum intensity	Minimum intensity	Minimum intensity	Maximum intensity	Maximum intensity	Maximum intensity (a)	Maximum beam spread	
200 000	15	7	3	7	250	1	7 500	7°
100 000	75	3	3	3	125	5	3 750	7°
20 000	15	7	3	7	25	1	750	N/A
2 000	1	7	3	7	2	1	75	N/A

Note: This table does not include recommended horizontal beam spreads. Therefore, the number of lights needed to meet this requirement shall depend on the horizontal beam spreads of each light as well as the shape of the obstacle. Thus, with narrower beam spreads, more lights shall be required.

- (a) 360° horizontal. All intensities are expressed in Candela. For flashing lights, the intensity is read into effective intensity.
- (b) Elevation vertical angles are referenced to the horizontal when the light unit is levelled.
- (c) Beam spread is defined as the angle between the horizontal plane and the directions for which the intensity exceeds that mentioned in the “intensity” column.

Note: An extended beam spread may be necessary under specific configuration and justified by an aeronautical study.

### **167. Marking of Fixed Objects**

- (1) All fixed objects to be marked shall, whenever practicable, be coloured, but where is not practicable, markers or flags shall be displayed on or above them, except that objects that are sufficiently conspicuous by their shape, size or colour need not be otherwise marked.
- (2) Pursuant to sub-regulation (1):
  - (a) An object shall be coloured to show a chequered pattern where it has essentially unbroken surfaces and its projection on any vertical plane equals or exceed 4.5 m in both dimensions;
  - (b) The pattern shall consist of rectangles of not less than 1.5 m and not more than 3 m on a side, the corners being of the darker colour;
  - (c) The colours of the pattern shall contrast each with the other and with the background against which they shall be seen; and
  - (d) Orange and white or alternatively red and white shall be used, except where such colours merge with the background; as indicated in Figure 1.
- (3) An object shall be coloured to show alternating contrasting bands if:
  - (a) it has essentially unbroken surfaces and has one dimension, horizontal or vertical, greater than 1.5 m, and the other dimension, horizontal or vertical, less than 4.5 m; or
  - (b) it is of skeletal type with either a vertical or a horizontal dimension greater than 1.5 m.
- (4) Subject to sub regulation (3);
  - (a) the bands shall be perpendicular to the longest dimension and have a width approximately 1/7 of the longest dimension or 30 m, whichever is less;
  - (b) the colours of the bands shall contrast with the background against which they shall be seen;
  - (c) orange and white shall be used, except where such colours are not conspicuous when viewed against the background; and
  - (d) the bands on the extremities of the object shall be of the darker colour; as indicated in Figures 1 and 2.

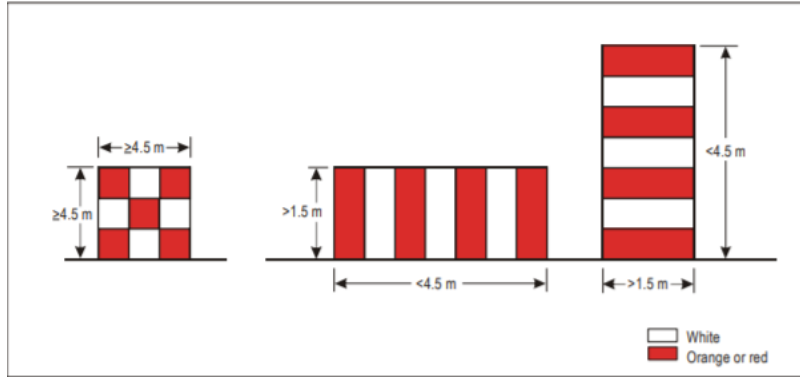

**Figure 1. Basic Marking Patterns**

- (5) The formula for determining bandwidth and for having an odd number of bands, thus permitting both the top and bottom bands to be of the darker colour shall be as indicated in Table 7.

**Table 7. – Marking Band Widths**

Longest dimension		Band width
Greater than	Not exceeding	
1.5 m	210 m	1/7 of longest dimension
210 m	270 m	1/9 of longest dimension
270 m	330 m	1/11 of longest dimension
330 m	390 m	1/13 of longest dimension
390 m	450 m	1/15 of longest dimension
450 m	510 m	1/17 of longest dimension
510 m	570 m	1/19 of longest dimension
570 m	630 m	1/21 of longest dimension

- (6) An object shall be coloured in a single conspicuous colour where its projection on any vertical plane has both dimensions less than 1.5 m and orange or red shall be used, except where such colours merge with the background, in which case it may be necessary to use a different colour from orange or red to obtain sufficient contrast.

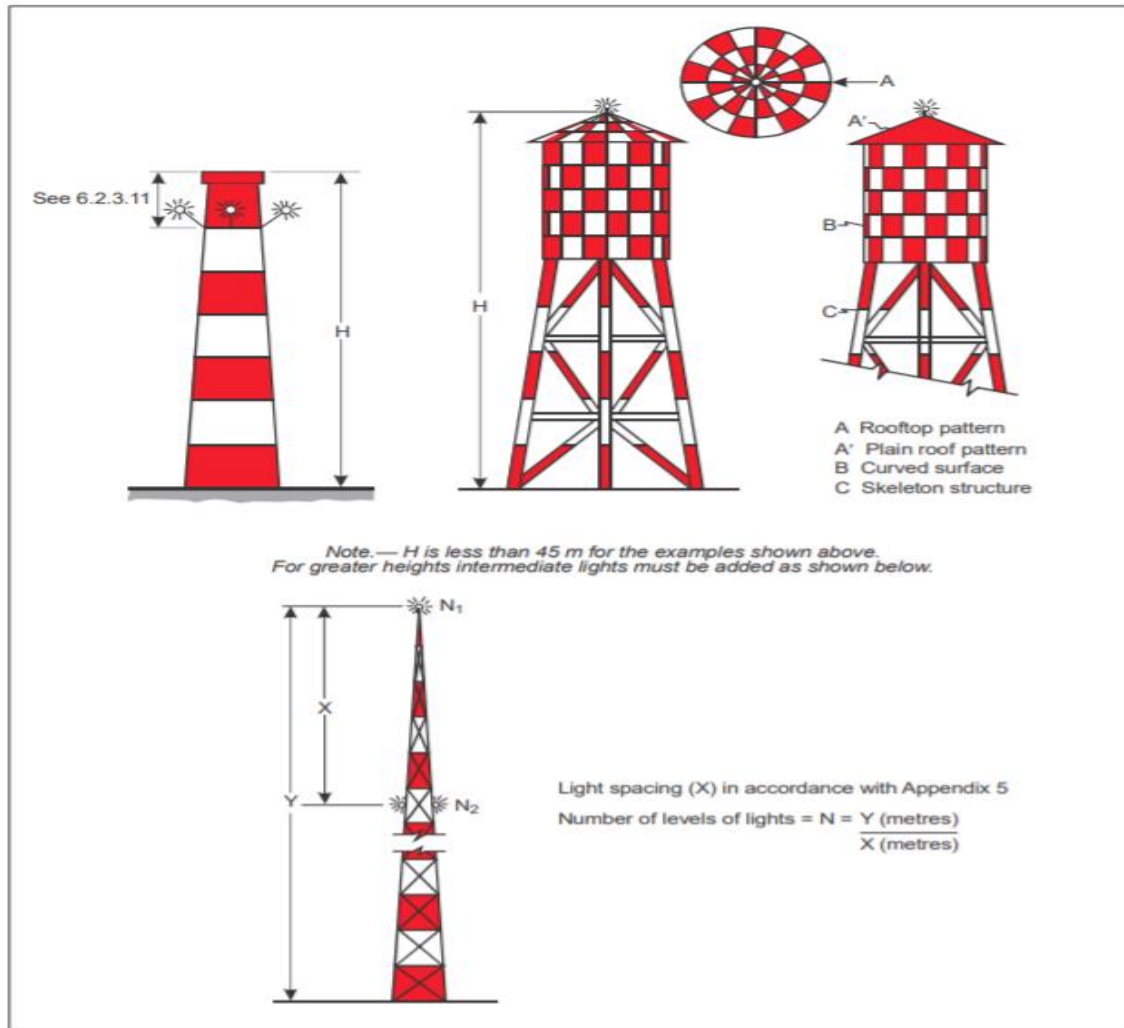

**Figure 2: Marking and Lighting of Tall Structures**

### 168. Marking By Flags

- (1) Flags used to mark fixed objects shall be displayed around, on top of, or around the highest edge of, the object and when flags are used to mark extensive objects or groups of closely spaced objects, they shall be displayed at least every 15 m and such flags shall not increase the hazard presented by the object they mark.
- (2) Flags used to mark fixed objects shall not be less than 0.6 m on each side.
- (3) Flags used to mark fixed objects shall be orange in colour or a combination of two triangular sections, one orange and the other white, or one red and the other white, except that where such colours merge with the background other conspicuous colours shall be used.
- (4) Markers displayed on or adjacent to objects shall be located in conspicuous positions

so as to retain the general definition of the object and shall be recognizable in clear weather from a distance of at least 1 000 m for an object to be viewed from the air and 300 m for an object to be viewed from the ground in all directions in which an aircraft is likely to approach the object.

- (5) Pursuant to sub-regulation (4) the shape of markers shall be distinctive to the extent necessary to ensure that they are not mistaken for markers employed to convey other information, and they shall be such that the hazard presented by the object they mark is not increased.
- (6) A marker shall be of one colour and when installed, white and red, or white and orange markers shall be displayed alternately and the colour selected shall contrast with the background against which it shall be seen.

### **169. Lighting of Fixed Objects**

- (1) In the case of an object to be lighted, one or more low-, medium- or high-intensity obstacle lights shall be located as close as practicable to the top of the object.
- (2) In the case of chimney or other structure of like function, the top lights shall be placed sufficiently below the top so as to minimize contamination by smoke, etc. as indicated in Figure 2.
- (3) In the case of a tower or antenna structure indicated by high-intensity obstacle lights by day with an appurtenance, such as a rod or an antenna, greater than 12 m where it is not practicable to locate a high-intensity obstacle light on the top of the appurtenance, such a light shall be located at the highest practicable point and, where practicable, a medium-intensity obstacle light, Type A, mounted on the top.
- (4) In the case of an extensive object or of a group of closely spaced objects to be lighted that are:
  - (a) penetrating a horizontal obstacle limitation surface (OLS) or located outside an OLS, the top lights shall be so arranged as to at least indicate the points or edges of the object highest in relation to the obstacle limitation surface or above the ground, and so as to indicate the general definition and the extent of the objects; and
  - (b) penetrating a sloping OLS, the top lights shall be so arranged as to at least indicate the points or edges of the object highest in relation to the OLS, and so as to indicate the general definition and the extent of the objects, and where two or more edges are of the same height, the edge nearest the landing area shall be marked.
- (5) When the obstacle limitation surface concerned is sloping and the highest point above the OLS is not the highest point of the object, additional obstacle lights shall be placed on the highest point of the object.

- (6) Where lights are applied to display the general definition of an extensive object or a group of closely spaced objects, and:
  - (a) low-intensity lights are used, they shall be spaced at longitudinal intervals not exceeding 45 m; and
  - (b) Medium-intensity lights are used, they shall be spaced at longitudinal intervals not exceeding 900 m.
- (7) High-intensity obstacle lights, Type A, and medium-intensity obstacle lights, Types A and B, located on an object shall flash simultaneously.
- (8) The installation setting angles for high-intensity obstacle lights, Type A, shall be in accordance with Table 8, except that where high-intensity obstacle lights are intended for day use as well as night use, care shall be taken to ensure that these lights do not create disconcerting dazzle.
- (9) The design, location and operation of high-intensity obstacle lights shall be in accordance with these Regulations.
- (10) Where, in the opinion of the appropriate authority, the use of high-intensity obstacle lights, Type A, or medium-intensity obstacle lights, Type A, at night may dazzle pilots in the vicinity of an aerodrome (within approximately 10 000 m radius) or cause significant environmental concerns, a dual obstacle lighting system shall be provided, in which case, this system shall be composed of high-intensity obstacle lights, Type A, or medium-intensity obstacle lights, Type A, as appropriate, for daytime and twilight use and medium-intensity obstacle lights, Type B or C, for night-time use.

**170. Lighting of Objects with Height Less Than 45 M Above Ground Level**

- (1) Low-intensity obstacle lights, Type A or B, shall be used where the object is a less extensive one and its height above the surrounding ground is less than 45 m.
- (2) Where the use of low-intensity obstacle lights, Type A or B, would be inadequate or an early special warning is required, then medium- or high-intensity obstacle lights shall be used.
- (3) Low-intensity obstacle lights, Type B, shall be used either alone or in combination with medium-intensity obstacle lights, Type B, in accordance with sub-regulation (4).
- (4) Medium-intensity obstacle lights, Type A, B or C, shall be used where the object is an extensive one (including a group of buildings), and medium-intensity obstacle lights, Types A and C, shall be used alone, whereas medium-intensity obstacle lights, Type B, shall be used either alone or in combination with low-intensity obstacle lights, Type B.

**171. Lighting of Objects with A Height 45m or More to A Height Less Than 150 M Above Ground Level**

- (1) Medium-intensity obstacle lights, Type A, B or C, shall be used for lighting objects with a height of 45 m to a height less than 150 m above ground level, medium-intensity obstacle lights, Types A and C, shall be used alone, whereas medium-intensity obstacle lights, Type B, shall be used either alone or in combination with low-intensity obstacle lights, Type B.
- (2) Where an object is indicated by medium-intensity obstacle lights, Type A, and the top of the object is more than 105 m above the level of the surrounding ground or the elevation of tops of nearby buildings (when the object to be marked is surrounded by buildings), additional lights shall be provided at intermediate levels.
- (3) Pursuant to sub-regulation (2), these additional intermediate lights shall be spaced as equally as practicable, between the top lights and ground level or the level of tops of nearby buildings, as appropriate, with the spacing not exceeding 105 m.
- (4) Where an object is indicated by medium-intensity obstacle lights, Type B, and the top of the object is more than 45 m above the level of the surrounding ground or the elevation of tops of nearby buildings (when the object to be marked is surrounded by buildings), additional lights shall be provided at intermediate levels.
- (5) Pursuant to sub-regulation (4), these additional intermediate lights shall be alternately low-intensity obstacle lights, Type B, and medium-intensity obstacle lights, Type B, and shall be spaced as equally as practicable between the top lights and ground level or the level of tops of nearby buildings, as appropriate, with the spacing not exceeding 52 m.
- (6)
  - (a) Where an object is indicated by medium-intensity obstacle lights, Type C, and the top of the object is more than 45 m above the level of the surrounding ground or the elevation of tops of nearby buildings (when the object to be marked is surrounded by buildings), additional lights shall be provided at intermediate levels.
  - (b) These additional intermediate lights shall be spaced as equally as practicable, between the top lights and ground level or the level of tops of nearby buildings, as appropriate, with the spacing not exceeding 52 m.
- (7) Where high-intensity obstacle lights, Type A, are used, they shall be spaced at uniform intervals not exceeding 105 m between the ground level and the top light(s), except that where an object to be marked is surrounded by buildings, the elevation of the tops of the buildings may be used as the equivalent of the ground level when determining the number of light levels.

**172. Lighting of Objects with A Height 150 M or More Above Ground Level**

- (1) High-intensity obstacle lights, Type A, shall be used to indicate the presence of an object where its height above the level of the surrounding ground exceeds 150 m and an aeronautical study indicates such lights to be essential for the recognition of the object by day.
- (2) Where high-intensity obstacle lights, Type A, are used, they shall be spaced at uniform intervals not exceeding 105 m between the ground level and the top light(s), except that where an object to be marked is surrounded by buildings, the elevation of the tops of the buildings may be used as the equivalent of the ground level when determining the number of light levels.
- (3) Where, in the opinion of the appropriate authority, the use of high-intensity obstacle lights, Type A, at night may dazzle pilots in the vicinity of an aerodrome (within approximately 10 000 m radius) or cause significant environmental concerns, medium-intensity obstacle lights, Type C, shall be used alone, whereas medium-intensity obstacle lights, Type B, shall be used either alone or in combination with low-intensity obstacle lights, Type B.
- (4)
  - (a) Where an object is indicated by medium-intensity obstacle lights, Type A, additional lights shall be provided at intermediate levels.
  - (b) These additional intermediate lights shall be spaced as equally as practicable, between the top lights and ground level or the level of tops of nearby buildings, as appropriate, with the spacing not exceeding 105 m.
- (5) Where an object is indicated by medium-intensity obstacle lights, Type B, additional lights shall be provided at intermediate levels and these additional intermediate lights shall be alternately low-intensity obstacle lights, Type B, and medium-intensity obstacle lights, Type B, and shall be spaced as equally as practicable between the top lights and ground level or the level of tops of nearby buildings, as appropriate, with the spacing not exceeding 52 m.
- (6) Where an object is indicated by medium-intensity obstacle lights, Type C, additional lights shall be provided at intermediate levels and these additional intermediate lights shall be spaced as equally as practicable, between the top lights and ground level or the level of tops of nearby buildings, as appropriate, with the spacing not exceeding 52 m.

**173. Marking of Wind Turbines**

- (1) A wind turbine shall be marked and/or lighted where the Authority determines that the wind turbine is an obstacle.
- (2) The rotor blades, nacelle and upper 2/3 of the supporting cast of wind turbines shall be painted white, unless otherwise indicated by an aeronautical study.

#### **174. Lighting of Wind Turbines**

- (1) When lighting is deemed necessary, medium-intensity obstacle lights shall be used and in the case of a wind farm, i.e., a group of two or more wind turbines, it shall be regarded as an extensive object and the lights shall be installed:
  - (a) to identify the perimeter of the wind farm;
  - (b) respecting the maximum spacing between the lights along the perimeter, unless a dedicated assessment shows that a greater spacing can be used;
  - (c) so that, where flashing lights are used, they flash simultaneously; and
  - (d) so that, within a wind farm, any wind turbines of significantly higher elevation are also identified wherever they are located; and
  - (e) at locations prescribed in paragraphs (a), (b) and (d), respecting the following criteria:
    - (i) for wind turbines of less than 150 m in overall height (hub height plus vertical blade height), medium intensity lighting on the nacelle shall be provided;
    - (ii) for wind turbines from 150 m to 315 m in overall height, in addition to the medium intensity light installed on the nacelle, a second light serving as an alternate shall be provided in case of failure of the operating light. The lights shall be installed to assure that the output of either light is not blocked by the other;
    - (iii) in addition, for wind turbines from 150 m to 315 m in overall height, an intermediate level at half the nacelle height of at least 3 low intensity Type E lights, as specified in Regulation 164 (3) shall be provided, but where an aeronautical study shows that low intensity type E lights are not suitable, low-intensity type A or B lights may be used; and
    - (iv) for wind turbines of more than 315 m of overall height additional marking and lighting may be required as determined by an aeronautical study.
- (2) The obstacle lights shall be installed on the nacelle in such a manner as to provide an unobstructed view for aircraft approaching from any direction.
- (3) Where lighting is deemed necessary for a single wind turbine or short line of wind turbines, the installation shall be in accordance with sub-regulation (1) (e) above or as determined by an aeronautical study.

#### **175. Marking of Overhead Wires And/Or, Cables, and Supporting Towers**

- (1) The wires and/or cables, to be marked shall be equipped with markers and the supporting tower shall be coloured.
- (2) The supporting towers of overhead wires and cables, that require marking shall be

marked in accordance with Regulations 166(1) to 166(6), except that the marking may be omitted when they are lighted by high-intensity obstacle lights by day.

- (3) Markers displayed on or adjacent to objects shall be located in conspicuous positions so as to retain the general definition of the object and shall be recognizable in clear weather from a distance of at least 1 000 m for an object to be viewed from the air and 300 m for an object to be viewed from the ground in all directions in which an aircraft is likely to approach the object.
- (4) Subject to sub-regulation (3), the shape of markers shall be distinctive to the extent necessary to ensure that they are not mistaken for markers employed to convey other information, and they shall be such that the hazard presented by the object they mark is not increased.
- (5) A marker displayed on an overhead wire and/or cable shall be spherical and have a diameter of not less than 60 cm.
- (6) The spacing between two consecutive markers or between a marker and a supporting tower shall be appropriate to the diameter of the marker, but in no case shall the spacing exceed:
  - (a) 30 m where the marker diameter is 60 cm progressively increasing with the diameter of the marker to;
  - (b) 35 m where the marker diameter is 80 cm and further progressively increasing to a maximum of;
  - (c) 40 m where the marker diameter is of at least 130 cm;
- (7) where multiple wires and/or cables are involved, a marker shall be located not lower than the level of the highest wire at the point marked.
- (8) A marker shall be of one colour and when installed, white and red, or white and orange markers shall be displayed alternately and the colour selected shall contrast with the background against which it shall be seen.
- (9) When it has been determined that an overhead wire and/or, cable needs to be marked but it is not practicable to install markers on the wire and/or cable then high-intensity obstacle lights, Type B, shall be provided on their supporting towers.

#### **176. Lighting of Overhead Wires And/Or, Cables, and Supporting Towers**

- (1) High-intensity obstacle lights, Type B, shall be used to indicate the presence of a tower supporting overhead wires and/or cables where:
  - (a) an aeronautical study indicates such lights to be essential for the recognition of the presence of wires or cables; or
  - (b) it has not been found practicable to install markers on the wires and/or cables.

- (2) Where high-intensity obstacle lights, Type B, are used, they shall be located at three levels:
- (a) at the top of the tower;
  - (b) at the lowest level of the catenary of the wires or cables;
  - (c) at approximately midway between these two levels; and
  - (d) in some cases, this may require locating the lights off the tower.
- (3) High-intensity obstacle lights, Type B, indicating the presence of a tower supporting overhead wires and/or cables shall flash sequentially; first the middle light, second the top light and last, the bottom light, and the intervals between flashes of the lights shall approximate the following ratios:

<b>Flash interval between</b>	<b>Ratio of cycle time</b>
middle and top light	1/13
top and bottom light	2/13
bottom and middle light	10/13

- (4) where high intensity obstacle lights are intended for day use as well as for night use, care shall be taken to ensure that these lights do not create disconcerting dazzle.
- (5) Where, in the opinion of the appropriate authority, the use of high-intensity obstacle lights, Type B, at night may dazzle pilots in the vicinity of an aerodrome (within approximately 10 000 m radius) or cause significant environmental concerns, a dual obstacle lighting system shall be provided.
- (6) The dual obstacle lighting system required by sub-regulation (4) shall be composed of high-intensity obstacle lights, Type B, for daytime and twilight use and medium-intensity obstacle lights, Type B, for night-time use and where medium-intensity lights are used they shall be installed at the same level as the high-intensity obstacle light Type B.
- (7) The installation setting angles for high-intensity obstacle lights, Type B, shall be in accordance with Table 8.

Table 8. Installation setting angles for high-intensity obstacle lights

Height of light unit above terrain (AGL)		Angle of the peak of the beam above the horizontal
greater than	Not exceeding	
151 m		0°
122 m	151 m	1°
92 m	122 m	2°
	92 m	3°

## CHAPTER IX VISUAL AIDS FOR DENOTING RESTRICTED USE AREAS

### 177. Marking of Restricted Use Areas

- (1) An operator shall ensure that restricted areas are marked in a manner that is visible to aircraft operating on the ground and in the air.
- (2) An aerodrome operator shall adhere to the visual aids' requirements prescribed in these Regulations so as to ensure that aircraft operations can be conducted safely on the aerodrome.

### 178. Marking and Lighting of Closed Runways and Taxiways, or Parts Thereof

- (1) A closed marking shall be displayed on a runway or taxiway, or portion thereof, which is permanently closed to the use of all aircraft.
- (2) A closed marking shall be displayed on a temporarily closed runway or taxiway or portion thereof, except that such marking may be omitted when the closing is of short duration (less than 3 days) and adequate warning by air traffic services is provided.
- (3) On a runway, a closed marking shall be placed at each end of the runway, or portion thereof, declared closed, and additional markings shall be so placed that the maximum interval between markings does not exceed 300m and on a taxiway a closed marking shall be placed at least at each end of the taxiway or portion thereof closed.
- (4) The closed marking shall be of the form and proportions as detailed in Figure 3, Illustration a), when displayed on a runway, and shall be of the form and proportions as detailed in Figure 3 (Illustration b), when displayed on a taxiway and the marking shall be white when displayed on a runway and shall be yellow when displayed on a taxiway.
- (5) When an area is temporarily closed, frangible barriers or markings utilizing materials other than paint or other suitable means may be used to identify the closed area.

- (6) When a runway or taxiway or portion thereof is permanently closed, all normal runway and taxiway markings shall be obliterated.

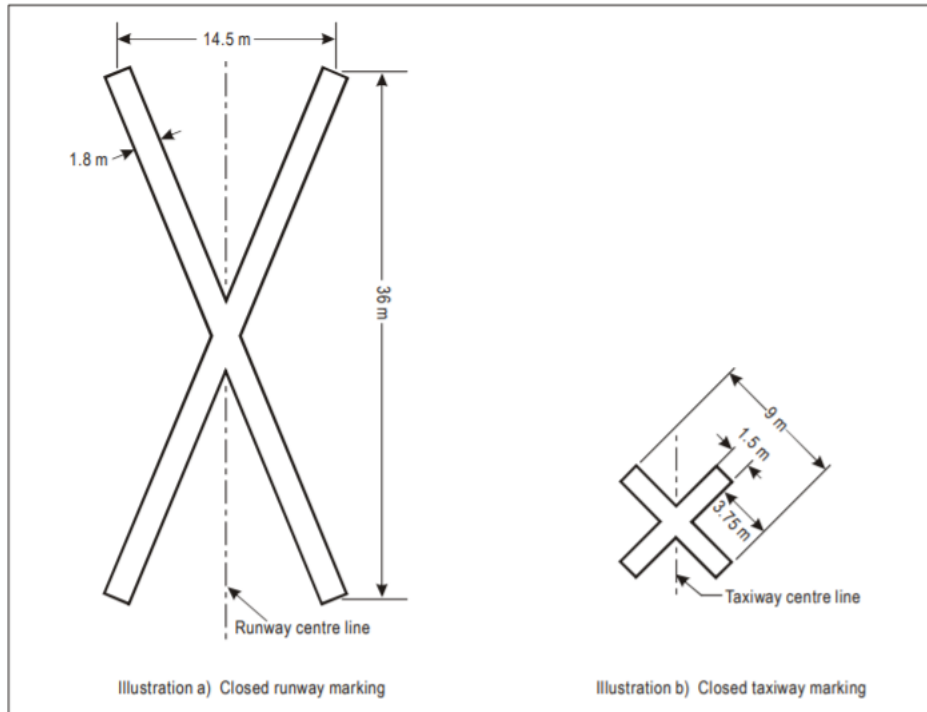

**Figure 3. Closed Runway and Taxiway Markings**

- (7) Lighting on a closed runway or taxiway or portion thereof shall not be operated, except as required for maintenance purposes.
- (8) In addition to closed markings, when the runway or taxiway or portion thereof closed is intercepted by a usable runway or taxiway which is used at night, un-serviceability lights shall be placed across the entrance to the closed area at intervals not exceeding 3m.

### **179. Marking of Non-Load-Bearing Surfaces**

- (1) Shoulders for taxiways, runway turn pads, holding bays and aprons and other non-load-bearing surfaces, which cannot readily be distinguished from load-bearing surfaces and which, where used by aircraft, might result in damage to the aircraft shall have the boundary between such areas and the load-bearing surface marked by a taxi side stripe marking.
- (2) A taxi side stripe marking shall be placed along the edge of the load-bearing pavement, with the outer edge of the marking approximately on the edge of the load-bearing pavement.
- (3) A taxi side stripe marking shall consist of a pair of solid lines, each 15cm wide and

spaced 15cm apart and the same colour as the taxiway centre line marking.

### 180. Marking of Pre-Threshold Areas

- (1) When the surface before a threshold is paved and exceeds 60m in length and is not suitable for normal use by aircraft, the entire length before the threshold shall be marked with a chevron marking.
- (2) A chevron marking shall point in the direction of the runway and be placed as shown in Figure 4.

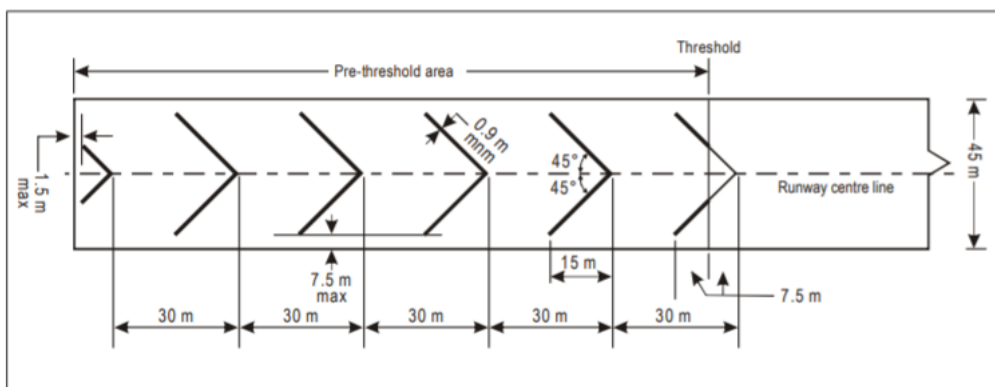

**Figure 4. Pre-Threshold Marking**

- (3) A chevron marking shall be of conspicuous colour and contrast with the colour used for the runway markings; it shall preferably be yellow. It shall have an over-all width of at least 0.9m.

### 181. Marking and Lighting of Unserviceable Areas

- (1) Un-serviceability markers shall be displayed wherever any portion of a taxiway, apron or holding bay is unfit for the movement of aircraft but it is still possible for aircraft to bypass the area safely and shall also be displayed at the entrances to a permanently or temporarily closed runway or taxiway, or part thereof whereas on a movement area used at night, un-serviceability lights shall be used.
- (2) Un-serviceability markers and lights shall be placed at intervals sufficiently close so as to delineate the unserviceable area.
- (3) Un-serviceability markers shall consist of conspicuous upstanding devices such as flags, cones or marker boards.
- (4) An un-serviceability light shall consist of a red fixed light and the light shall have intensity sufficient to ensure conspicuity considering the intensity of the adjacent lights and the general level of illumination against which it would normally be viewed and in no case shall the intensity be less than 10 cd of red light.

- (5) An un-serviceability cone shall be at least 0.5m in height and red, orange or yellow or any one of these colours in combination with white.
- (6) An un-serviceability flag shall be at least 0.5m square and red, orange or yellow or any one of these colours in combination with white.
- (7) An un-serviceability marker board shall be at least 0.5m in height and 0.9m in length, with alternate red and white or orange and white vertical stripes.

## **CHAPTER X ELECTRICAL SYSTEMS**

### **182. Electrical Power Supply Systems for Air Navigation Services and Facilities**

- (1) An aerodrome operator shall not operate an aerodrome unless adequate primary power supply systems are made available for the safe functioning of air navigation facilities.
- (2) The design and provision of electrical power systems for aerodrome visual and radio navigation aids shall be such that an equipment failure shall not leave the pilot with inadequate visual and non-visual guidance or misleading information.
- (3) The design and installation of the electrical systems shall take into consideration factors that can lead to malfunction, such as electromagnetic disturbances, line losses, power quality, among others.
- (4) Where secondary power is required for air navigation services and facilities, the operator shall arrange the electric power supply connections so as to ensure that the facilities are automatically connected to the secondary power supply upon failure of the primary power supply.
- (5) For purposes of sub regulation (4), the time interval between failure of the primary source of power and the complete restoration of the services shall be as short as practicable, except that for visual aids associated with non-precision, precision approach or take-off runways the requirements of Table 11 for maximum switch-over times shall apply.
- (6) For a precision approach runway, a secondary power supply capable of meeting the requirements of Table 11 for the appropriate category of precision approach runway shall be provided.
- (7) Electric power supply connections to those facilities for which secondary power is required shall be so arranged that the facilities are automatically connected to the secondary power supply on failure of the primary source of power.
- (8) For a runway meant for take-off in runway visual range conditions less than a value of 800 m, a secondary power supply capable of meeting the relevant requirements of

Table 11 shall be provided.

- (9) At an aerodrome where the primary runway is a non-precision approach runway, a secondary power supply capable of meeting the requirements of Table 11 shall be provided, except that a secondary power supply for visual aids need not be provided for more than one non-precision approach runway.
- (10) At an aerodrome where the primary runway is a non-instrument runway, a secondary power supply capable of meeting requirements of sub-regulation (6) shall be provided, except that a secondary power supply for visual aids need not be provided when an emergency lighting system is provided and capable of being deployed in 15 minutes.
- (11) The following aerodrome facilities with secondary power supply capable of supplying power where there is a failure of the primary power supply:
  - (a) the signalling lamp and the minimum lighting necessary to enable air traffic services personnel to carry out their duties;
  - (b) all obstacle lights which, in the opinion of the appropriate authority are essential to ensure the safe operation of aircraft;
  - (c) approach, runway and taxiway lighting;
  - (d) meteorological equipment;
  - (e) essential security lighting, where provided;
  - (f) essential equipment and facilities for the aerodrome responding emergency agencies;
  - (g) floodlighting on a designated isolated aircraft parking position where provided; and
  - (h) illumination of apron areas over which passengers may walk.
- (12) Requirements for a secondary power supply shall be met by either of the following:
  - (a) independent public power, which is a source of power supplying the aerodrome service from a substation other than the normal substation through a transmission line following a route different from the normal power supply route and such that the possibility of a simultaneous failure of the normal and independent public power supplies is extremely remote; or
  - (b) standby power unit(s), which are engine generators, batteries, etc., from which electric power can be obtained.

**179. Table 11 - Secondary Power Supply Requirements**

**Table 11 - Secondary power supply requirements**

Runway Type	Lighting aids requiring power	Maximum switch-over time
Non-instrument	Visual approach slope indicators <sup>a</sup>	15 seconds
	Runway edge <sup>b</sup>	15 seconds
	Runway threshold <sup>b</sup>	15 seconds
	Runway end <sup>b</sup>	15 seconds
	Obstacle	15 seconds
Non-precision approach	Approach lighting system	15 seconds
	Visual approach slope indicators <sup>ad</sup>	15 seconds
	Runway edge <sup>d</sup>	15 seconds
	Runway threshold <sup>d</sup>	15 seconds
	Runway end	15 seconds
Precision approach category I	Obstacle <sup>a</sup>	15 seconds
	Approach lighting system	15 seconds
	Visual approach slope indicators <sup>ad</sup>	15 seconds
	Runway edge <sup>d</sup>	15 seconds
	Runway threshold <sup>d</sup>	15 seconds
Precision approach category II	Runway end	15 seconds
	Essential taxiways <sup>a</sup>	15 seconds
	Obstacle <sup>a</sup>	15 seconds
	Inner 300 m of the approach lighting system	1 second
	Other parts of the approach lighting system	15 seconds
	Obstacle <sup>a</sup>	1 second
	Runway edge	1 second
	Runway threshold	1 second
	Runway end	1 second
	Runway centre line	1 second
	Runway touchdown zone	15 seconds
All stop bars		
Essential taxiway		

Note:

- (a) Supplied with secondary power when their operation is essential to the safety of flight operation.
- (b) See Part XIV– Visual aids for air navigation, regarding the use of emergency lighting.
- (c) One second where no runway center line lights are provided.
- (d) One second where approaches are over hazardous or precipitous terrain.

### **183. Electrical System Design**

- (1) For a runway meant for use in runway visual range conditions less than a value of 550 m, the electrical systems for the power supply, lighting and control of the lighting systems included in Table 11 shall be so designed that an equipment failure shall not leave the pilot with inadequate visual guidance or misleading information.
- (2) Where the secondary power supply of an aerodrome is provided by the use of duplicate feeders, such supplies shall be physically and electrically separate so as to ensure the required level of availability and independence.
- (3) Where a runway forming part of a standard taxi-route is provided with runway lighting and taxiway lighting, the lighting systems shall be interlocked to preclude the possibility of simultaneous operation of both forms of lighting.

### **184. Monitoring of Electrical Systems**

- (1) A system of monitoring shall be employed to indicate the operational status of the lighting systems.
- (2) Where lighting systems are used for aircraft control purposes, such systems shall be monitored automatically so as to provide an indication of any fault which may affect the control functions and this information shall be relayed to the air traffic service unit
- (3) Where a change in the operational status of lights has occurred, an indication may be provided within two seconds for a stop bar at a runway holding position and within five seconds for all other types of visual aids.
- (4) For a runway meant for use in runway visual range conditions less than a value of 550 m, the lighting systems detailed in Table 11 shall be monitored automatically so as to provide an indication when the serviceability level of any element falls below the minimum serviceability level specified in Regulation. and this information shall automatically be relayed to the maintenance crew.
- (5) For a runway meant for use in runway visual range conditions less than a value of 550 m, the lighting systems detailed in Table 11 shall be monitored automatically to provide an indication when the serviceability level of any element falls below the minimum level specified below which operations shall not continue; and this information shall be automatically relayed to the air traffic services unit and displayed in a prominent position.

**CHAPTER XI**  
**AERODROME OPERATIONAL SERVICES, EQUIPMENT, INSTALLATIONS AND**  
**FACILITIES**

Aerodrome Emergency Planning

**185. Application**

The regulations relating to Aerodrome Emergency Planning shall apply to all aerodromes commensurate with the size and complexity of their operations.

**186. General Aerodrome Emergency Planning Requirements**

- (1) An aerodrome operator shall establish an aerodrome emergency plan at the aerodrome commensurate with the most demanding aircraft operations and other activities conducted at the aerodrome.
- (2) The aerodrome emergency plan shall provide for the coordination of the actions to be taken in the event of an emergency occurring at the aerodrome or in its vicinity.
- (3) Aerodrome emergencies shall include:
  - (a) aircraft emergencies;
  - (b) sabotage including bomb threats;
  - (c) unlawfully seizure of aircraft;
  - (d) dangerous goods occurrences;
  - (e) building fires;
  - (f) natural disasters; and
  - (g) public health emergencies.
- (4) Subject to sub-regulation (3) (g), public health emergencies shall include:
  - (a) increased risk of travellers or cargo spreading a serious communicable disease internationally through air transport; and
  - (b) severe outbreak of a communicable disease potentially affecting a large proportion of aerodrome staff.
- (5) The aerodrome emergency plan shall set forth the procedures for coordinating the response or participation of all existing agencies which, in the opinion of the appropriate authority would be of assistance in responding to an emergency, including:
  - (a) at an aerodrome;
    - (i) air traffic control unit;
    - (ii) rescue and firefighting services;
    - (iii) aerodrome administration;
    - (iv) medical, port health and ambulance services;
    - (v) aircraft operators;
    - (vi) security services; and

- (vii) airport police unit.
- (b) outside the aerodromes:
  - (i) fire departments;
  - (ii) Police services;
- (c) health authorities including medical, ambulance services, hospitals and public health services:
  - (i) the military forces;
  - (ii) harbour patrol or coast guard
- (6) Public health services shall include planning to minimize adverse effects to the community from health-related events and deal with population health issues rather than provision of health services to individuals.
- (7) The aerodrome emergency plan shall provide for cooperation and coordination with the rescue coordination centre as necessary.
- (8) The aerodrome emergency plan shall include at least the following-
  - (a) the types of emergencies planned for;
  - (b) agencies to be involved in the plan;
  - (c) the responsibility and role of each agency, the emergency operation centre and the command post for each type of emergency;
  - (d) information on names and contacts of offices or people to be contacted in the case of a particular emergency; and
  - (e) a grid map of the aerodrome and its immediate vicinity.
- (9) In developing an aerodrome emergency plan, the aerodrome operator shall take into consideration the human factor principles to ensure optimum response by all existing agencies participating in the emergency operations.
- (10) An aerodrome operator shall engage the relevant stakeholders in the development of the aerodrome emergency plan.

**187. Emergency Planning Committee**

An operator shall form an emergency planning committee to discuss, determine and implement emergency planning arrangements commensurate with the size and type of aircraft that use the aerodrome.

**188. Emergency Operation Centre and Command Post**

- (1) An operator of an aerodrome shall ensure that a fixed emergency operation centre and a mobile command post available for use during an emergency.
- (2) The emergency operations centre shall be a part of the aerodrome facilities and shall be responsible for the overall coordination and general direction of the response to an emergency.

- (3) The command post shall be a facility capable of being moved rapidly to the site of an emergency, when required, and shall undertake the local coordination of those agencies responding to the emergency.
- (4) An operator shall ensure that a person is assigned to assume control of the emergency operations centre and, when appropriate, another person the mobile command post.

#### **189. Communication System**

An operator shall ensure that adequate communication systems linking the command post and the emergency operations centre with each other and with the participating agencies are provided in accordance with the plan and are consistent with the particular requirements of the aerodrome.

#### **190. Aerodrome Emergency Exercise**

- (1) The aerodrome emergency plan shall contain procedures for periodic testing of the adequacy of the plan and for reviewing the results in order to improve its effectiveness and shall include all participating agencies and associated equipment.
- (2) The aerodrome emergency plan required by sub-regulation (1) shall be tested by conducting:
  - (a) a full-scale aerodrome emergency exercise at intervals not exceeding two years and partial emergency exercises in the intervening year to ensure that any deficiencies found during the full-scale aerodrome emergency exercise have been corrected; or
  - (b) a series of modular tests commencing in the first year and concluding in a full-scale aerodrome emergency exercise at intervals not exceeding three years; and reviewed thereafter, or after an actual emergency, so as to correct any deficiency found during such exercises or actual emergency.

#### **191. Emergencies in Difficult Environment**

- (1) The aerodrome emergency plan shall include the ready availability of and coordination with appropriate specialist rescue services to be able to respond to emergencies where an aerodrome is located close to water and/or swampy areas and where a significant portion of approach or departure operations takes place over these areas.
- (2) At an aerodrome located close to a water body, a swampy area, or difficult terrain, the aerodrome emergency plan shall include the establishment, testing and assessment at regular intervals of a pre-determined response for the specialist rescue services.
- (3) An assessment of the approach and departure areas within 1,000 m of the runway threshold shall be carried out to determine the options available for intervention.

## **Rescue and Firefighting**

### **192. Provision of Aerodrome Rescue and Firefighting Services**

- (1) An aerodrome operator shall put in place rescue and firefighting equipment and services commensurate with the category of the aerodrome.
- (2) Public or private organizations, suitably located and equipped, may be designated to provide the rescue and firefighting service and where designated the fire station housing these organizations shall where possible be located on the aerodrome, although an off-aerodrome location is not precluded provided the response time can be met.
- (3) Where an aerodrome is located close to a water body, a swampy area or difficult terrain and where a significant portion of approach or departure operations takes place over such an area, specialist rescue services and fire-fighting equipment appropriate to the hazard and risk shall be made available.
- (4) Subject to sub-regulation (3), the aerodrome operator shall plan and deploy the necessary life-saving flotation equipment as expeditiously as possible in a number commensurate with the largest aeroplane normally using the aerodrome.

### **193. Level of Protection for Rescue and Firefighting Services to Be Provided**

- (1) The level of protection provided at an aerodrome for rescue and firefighting shall be appropriate to the aerodrome category determined using the principles in sub-regulation (2) and (3) below, except that, where the number of movements of the aeroplanes in the highest category normally using the aerodrome is less than 700 in the busiest consecutive three months, the level of protection provided shall be not less than one category below the determined category.
- (2) The aerodrome rescue and firefighting services category shall be determined using Table 9 and shall be based on the longest aeroplane that normally uses the aerodrome, and its fuselage width.
- (3) Where after selecting the aerodrome category appropriate to the longest aeroplane's overall length, that aeroplane's fuselage width is found to be greater than the maximum width in Table 9, column 3, for that category, then the category for that aeroplane shall be one category higher.
- (4) During anticipated periods of reduced activity, the level of protection available shall be no less than that needed for the highest category of aeroplane planned to use the aerodrome during that time irrespective of the number of movements.

**Table 9 – Aerodrome Category for Rescue and Fire Fighting**

<b>Aerodrome fire category</b>	<b>Aircraft overall length</b>	<b>Maximum fuselage width</b>
1	0 M up to but not including 9 M	2M
2	9 M up to but not including 12 M	2M
3	12 M up to but not including 18 M	3M
4	18 M up to but not including 24 M	4M
5	24 M up to but not including 28 M	4M
6	28 M up to but not including 39 M	5M
7	39 M up to but not including 49 M	5M
8	49 M up to but not including 61 M	7M
9	61 M up to but not including 76 M	7M
10	76 M up to but not including 90 M	8M

**194. Extinguishing Agents**

- (1) Both principal and complementary agents shall be provided at an aerodrome.
- (2) The principal extinguishing agent shall be:
  - (a) a foam meeting the minimum performance level A; or
  - (b) a foam meeting the minimum performance level B; or
  - (c) a foam meeting the minimum performance level C; or
  - (d) a combination of these agents;
  - (e) except that the principal extinguishing agent for aerodromes in categories 1 to 3 shall preferably meet the minimum performance level B or C foam.
- (3) The complementary extinguishing agent shall be a dry chemical powder suitable for extinguishing hydrocarbon fires, and care must be taken to ensure compatibility when

selecting dry chemical powder for use with foam; and alternate complementary agents having equivalent firefighting capability may be utilised.

- (4) The amounts of water for foam production and the complementary agents to be provided on the rescue and fire fighting vehicles shall be in accordance with the aerodrome category determined in accordance with Table 10 below, except that for aerodrome categories 1 and 2 up to 100 per cent of the water may be substituted with complementary agent.
- (5) For the purpose of agent substitution, 1 kg of complementary agent shall be taken as equivalent to 1.0 L of water for production of a foam meeting performance level A.
- (6) The amounts of water specified for foam production shall be predicated on an application rate of 8.2 L/min/m<sup>2</sup> for a foam meeting performance level A, 5.5 L/min/m<sup>2</sup> for a foam meeting performance level B and 3.75 L/min/m<sup>2</sup> for a foam meeting performance level C; and when any other complementary agent is used, the substitution ratios shall be checked.
- (7) At aerodromes where operations by aeroplanes larger than the average size in a given category are planned, the quantities of water shall be recalculated and the amount of water for foam production and the discharge rates for foam solution shall be increased accordingly.

**Table 10 - Minimum Usable Amounts of Extinguishing Agents**

	Foam meeting performance level A		Foam meeting performance level B		Foam meeting Performance level C		Complementary agents	
	Water (L)	Discharge rate (Foam solution/minute)	Water (L)	Discharge rate (Foam solution/minute)	Water (L)	Discharge rate (Foam solution/minute)	Dry Chemical Powder (DCP) (kg)	Discharge rate (kg/sec)
Aerodrom fire Category (1)	(2)	(5)	(4)	(5)	(6)	(7)	(8)	(9)

		( L )						
		( 3 )						
1	3 5 0	3 5 0	2 3 0	230	1 6 0	1 6 0	4 5	2.25
2	1 0 0 0	8 0 0	6 7 0	550	4 6 0	3 6 0	9 0	2.25
3	1 8 0 0	1 3 0 0	1 2 0 0	900	8 2 0	6 3 0	1 3 5	2.25
4	3 6 0 0	2 6 0 0	2 4 0 0	180 0	1 7 0 0	1 1 0 0	1 3 5	2.25
5	8 1 0 0	4 5 0 0	5 4 0 0	300 0	3 9 0 0	2 2 0 0	1 8 0	2.25
6	1 1 8 0 0	6 0 0 0	7 9 0 0	400 0	5 8 0 0	2 9 0 0	2 2 5	2.25
7	1 8 2 0 0	7 9 0 0	1 2 1 0 0	530 0	8 8 0 0	3 8 0 0	2 2 5	2.25
8	2 7 3	1 0 8	1 8 2	720 0	1 2 8	5 1 0 0	4 5 0	4.5

	0	0	0		0			
	0	0	0		0			
9	3	1	2	900	1	6	4	4.5
	6	3	4	0	7	3	5	
	4	5	3		1	0	0	
	0	0	0		0	0		
	0	0	0		0			
1	4	1	3	112	2	7	4	4.5
0	8	6	2	00	2	9	5	
	2	6	3		8	0	0	
	0	0	0		0	0		
	0	0	0		0			

- (8) The quantity of foam concentrates separately provided on vehicles for foam production shall be in proportion to the quantity of water provided and the foam concentrate selected.
- (9) The amount of foam concentrate provided on a vehicle shall be sufficient to produce at least two loads of foam solution.
- (10) Supplementary water supplies, for the expeditious replenishment of rescue and fire fighting vehicles at the scene of an aircraft accident, shall be provided.
- (11) When a combination of different performance level foams, provided at an aerodrome, the total amount of water to be provided for foam production shall be calculated for each foam type and the distribution of these quantities shall be documented for each vehicle and applied to the overall rescue and firefighting requirement.
- (12) The complementary agents shall comply with the appropriate specifications of the International Organization for Standardisation (ISO 7202 (Powder)).
- (13) The discharge rate of the foam solution and of complementary agents shall be no less than the values shown in Table 10.
- (14) Dry chemical powders shall only be substituted with an agent that has equivalent or better firefighting capabilities for all types of fires where complementary agent is expected to be used.
- (15) A reserve supply of foam concentrate, equivalent to 200 per cent of the quantities identified in Table 10, shall be maintained on the aerodrome for vehicle replenishment purposes and foam concentrate carried on fire vehicles in excess of the quantities specified in Table 10, shall be considered to contribute to the reserve.
- (16) A reserve supply of complementary agent, equivalent to 100 per cent of the quantity identified in Table 10, shall be maintained on the aerodrome for vehicle replenishment purposes and sufficient propellant gas shall be included to utilize this reserve complementary agent.

- (17) Category 1 and 2 aerodromes that have replaced up to 100 per cent of the water with complementary agent shall hold a reserve supply of complementary agent of 200 per cent.
- (18) Where a major delay in the replenishment of the supplies is anticipated, the amount of reserve supply required by sub-regulations (1), (2) and (3) shall be increased as determined by a risk assessment.

#### **195. Rescue Equipment**

An operator shall ensure that rescue equipment commensurate with the level of aircraft operations are provided on the rescue and fire fighting vehicles.

#### **196. Response Time for Rescue and Firefighting Services**

- (1) The operational objective of the rescue and firefighting service shall be to achieve a response time not exceeding three minutes to any point of each operational runway in optimum visibility and surface conditions.
- (2) The operational objective of the rescue and firefighting service shall be to achieve a response time not exceeding three minutes to any other part of the movement area in optimum visibility and surface conditions.
- (3) For the purpose of these regulations, response time means the time between the initial call to the rescue and firefighting service, and the time when the first responding vehicle is in position to apply foam at a rate of at least 50 per cent of the discharge rate specified in Table 10 and optimum visibility while optimum visibility and surface conditions means daytime, good visibility, no precipitation with normal response route free of surface contamination such as water.
- (4) To meet the operational objectives as nearly as possible in less than optimum conditions of visibility, especially during low visibility operations, suitable guidance, equipment and/or procedures for rescue and firefighting services shall be provided.
- (5) Any vehicles, other than the first responding vehicle(s), required to deliver the amounts of extinguishing agents specified in Table 10 shall ensure continuous agent application and shall arrive no more than four minutes from the initial call.
- (6) A system of preventive maintenance of rescue and fire fighting vehicles shall be employed to ensure effectiveness of the equipment and compliance with the specified response time throughout the life of the vehicle.

#### **197. Establishment of Emergency Access Roads**

- (1) Emergency access roads shall be provided on an aerodrome where terrain conditions permit the construction, so as to facilitate achieving minimum response times.
- (2) Particular attention shall be given to the provision of ready access to approach areas up to 1 000 m from the threshold, or at least within the aerodrome boundary and where a fence is provided, the need for convenient access to outside areas shall be taken into account.
- (3) Aerodrome service roads may serve as emergency access roads when they are suitably located and constructed.

- (4) Emergency access roads shall be capable of supporting the heaviest vehicles which shall use them, and be usable in all weather conditions.
- (5) Roads within 90 m of a runway shall be surfaced to prevent surface erosion and the transfer of debris to the runway. Sufficient vertical clearance shall be provided from overhead obstructions for the largest vehicles.
- (6) When the surface of the road is indistinguishable from the surrounding area, edge markers shall be placed at intervals of about 10 m.

**198. Fire Stations**

- (1) Rescue and fighting vehicles shall be housed in a fire station.
- (2) Fire stations shall be provided where the response time cannot be achieved from a single fire station.
- (3) The fire station shall be located so that the access for rescue and fire fighting vehicles into the runway area is direct and clear, requiring a minimum number of turns.

**199. Communication and Alerting Systems for Rescue and Firefighting Services**

- (1) An aerodrome operator shall provide a discrete communication system linking a fire station with the control tower, any other fire station on the aerodrome and the rescue and fire fighting vehicles.
- (2) An alerting system for rescue and firefighting personnel, capable of being operated from that station, shall be provided at a fire station, any other fire station on the aerodrome and at the aerodrome control tower.

**200. Number of Rescue and Fire Fighting Vehicles**

The minimum number of rescue and fire fighting vehicle provided at an aerodrome shall be in accordance with the following tabulation:

**Table 11 - Minimum Number of Rescue and Fire Fighting Vehicle**

<b>Aerodrome fire category</b>	<b>Number of rescue and fire fighting vehicles</b>
1	1
2	1
3	1
4	1
5	1
6	2

7	2
8	3
9	3
10	3

**201. Requirements for Rescue and Firefighting Personnel**

- (1) An aerodrome operator shall ensure that all rescue and firefighting personnel are properly trained to perform their duties in an efficient manner, and shall participate in live fire drills commensurate with the types of aircraft and type of rescue and firefighting equipment in use at the aerodrome, including pressure-fed fuel fires.
- (2) For the purpose of these regulations, pressure-fed fires are fires associated with fuel discharge under very high pressure from a ruptured fuel tank.
- (3) The rescue and firefighting personnel training programme shall include training in human performance, including team coordination.
- (4) During flight operations, sufficient trained and competent personnel shall be designated to be readily available to ride the rescue and fire fighting vehicles and to operate the equipment at maximum capacity.
- (5) The rescue and firefighting personnel shall be deployed in a way that ensures that minimum response times can be achieved and that continuous agent application at the appropriate rate can be fully maintained, taking into account, the need for the personnel to use hand lines, ladders and other rescue and firefighting equipment normally associated with aircraft rescue and firefighting operations.
- (6) In determining the minimum number of rescue and firefighting personnel required, a task resource analysis shall be completed and the level of staffing documented in the Aerodrome Manual.
- (7) All responding rescue and firefighting personnel shall be provided with protective clothing and respiratory equipment to enable them to perform their duties in an effective manner.

**202. Maintenance of Fire Prevention Programme**

- (1) An aerodrome operator shall establish a fire prevention programme with preventive measures against possible fires on the aerodrome and identify a person to maintain the fire prevention programme for the aerodrome and the aerodrome buildings.
- (2) Where an aerodrome does not have designated fire service, the aerodrome operator shall arrange with the relevant local government authority or any other concerned authority to maintain a fire prevention programme for the aerodrome and to advise the operator of any dangerous conditions for rectification.

- (3) An aerodrome operator shall ensure that unsafe practices that may result in fire are not performed on the aerodrome or within its vicinity.
- (4) Notwithstanding sub-regulation (3) where unsafe practices are performed during maintenance on the aerodrome, an operator shall alert the rescue and firefighting services concerned, to be on standby for the duration of the practices.

### **Disabled Aircraft Removal**

#### **203. Removal Of Disabled Aircraft**

- (1) An aerodrome operator shall have in place a plan for the removal of an aircraft disabled on, or adjacent to, the movement area and shall designate a coordinator to implement the plan when necessary.
- (2) The disabled aircraft removal plan shall be based on the characteristics of the aircraft that may normally be expected to operate at the aerodrome, and include among other things:
  - (a) a list of equipment and personnel on, or in the vicinity of, the aerodrome which would be available for such purpose; and
  - (b) arrangement for the rapid receipt of aircraft recovery equipment kits from other aerodromes, where applicable; and
  - (c) the name and contacts of the coordinator designated to implement the plan.
- (3) The plan under this regulation shall include particulars of the procedures for removing a disabled aircraft on the movement area or adjacent to it.

### **Wildlife Strike Hazard Reduction**

#### **204. Wildlife Hazard Management**

- (1) An operator shall, in consultation with the authority responsible for wildlife, take necessary action to control wildlife hazards at the aerodrome.
- (2) An operator shall ensure that procedures to deal with the danger posed to aircraft operations by the presence of wildlife in the aerodrome flight pattern or movement area are in place.
- (3) The wildlife management plan of an aerodrome shall be approved by the Authority and shall form part of the aerodrome manual.
- (4) The wildlife strike hazard on, or in the vicinity of, an aerodrome shall be assessed through.

#### **205. Wildlife Strike Hazard Reduction at Aerodrome**

- (1) An operator shall, in consultation with the authority responsible for wildlife, take all Reasonable steps to minimize the risks associated with wildlife strike hazards. The wildlife strikes hazard on or in the vicinity of, an aerodrome shall be assessed through.
- (2) An operator shall take practical measures to control the wildlife habitat at or around the aerodrome and to disperse birds, which are a potential hazard to aircraft operations.

- (3) A wildlife strike hazard on, or in the vicinity of, an aerodrome shall be assessed through:
  - (a) the establishment of a national procedure for recording and reporting wildlife strikes to aircraft;
  - (b) the collection of information from aircraft operators, aerodrome personnel, and other sources on the presence of wildlife on, or around the aerodrome constituting a potential hazard to aircraft operations.; and
  - (c) an on-going evaluation of the wildlife hazard by competent personnel.
- (4) The aerodrome operator shall collect and forward wildlife strike reports to the Authority for submission to ICAO for inclusion in the ICAO Bird Strike Information System (IBIS) database.
- (5) An aerodrome operator shall take action to decrease the risk to aircraft operations by adopting measures to minimize the likelihood of collisions between wildlife and aircraft.
- (6) An aerodrome operator in collaboration with the appropriate authorities shall take action to eliminate or to prevent the establishment of refuse collection sites, garbage disposal dumps, including landfills, or any other source which may attract wildlife to the aerodrome, or its vicinity, unless an appropriate wildlife assessment indicates that they are unlikely to create conditions conducive to a wildlife hazard problem.
- (7) Subject to sub-regulation (6), refuse collection sites, garbage disposal dumps and landfills shall be located no closer than a 13km radius circle centred on the aerodrome reference point and shall be located further, where located in the vicinity of an approach and take-off path of an aerodrome, except where studies of flight lines of birds attracted to these sites show that the birds shall not be problematic for the aerodrome.
- (8) Where the elimination of existing sites is not possible, the operator and the appropriate authorities shall ensure that any risk to aircraft posed by these sites is assessed and reduced to as low as reasonably practicable.
- (9) An aerodrome operator shall establish a local wildlife hazard management committee to manage wildlife hazard at the aerodrome.
- (10) An aerodrome operator shall establish aerodrome wildlife control unit, adequately equipped to control and manage wildlife hazard at the aerodrome.
- (11) The operator shall cause records of all aspects of wildlife hazard control to be kept and shall report all wildlife strikes to the Authority.
- (12) An operator shall monitor the local environment including any activities that may attract wildlife and in designing the wildlife hazard management programme, shall consider that environment and the activities that may attract wildlife.
- (13) The authority shall give due consideration to aviation safety concerns related to land developments in the vicinity of the aerodrome that may attract wildlife.

**206. National Committee on Wildlife Hazard Management**

There shall be a national committee on wildlife hazard management established by the national authority responsible for airports.

**207. Responsibilities of the National Committee on Wildlife Hazard Management**

The national committee on wildlife hazard management shall be responsible for:

- (a) analysing wildlife hazard problems at aerodromes;
- (b) carrying out research and development on wildlife hazard management;
- (c) acting as an interface between the aerodrome operators and air operators;
- (d) advising aerodrome operators on wildlife hazard management; and
- (e) reviewing the effectiveness of the wildlife hazard management programmes at aerodromes.

**208. Composition of the National Committee on Wildlife Hazard Management**

The national committee on wildlife hazard management shall consist of:

- (a) the Directorate of Aerodrome State Airports who shall be the chair;
- (b) representatives from the ministries responsible for civil aviation, local government, and defence;
- (c) aerodrome operator representatives;
- (d) aircraft operator representatives;
- (e) chairpersons of the airports' local wildlife hazard management committees;
- (f) air navigation service provider representatives;
- (g) agencies responsible for wildlife services; and
- (h) such other persons or agencies as may be deemed necessary.

**Apron Management Service**

**209. Provision of Apron Management Service**

- (1) When warranted by the volume of traffic and operating conditions, an appropriate apron management service shall be provided on an apron by an aerodrome air traffic services unit, by the aerodrome operating authority, or by a cooperative combination of these, in order to:
  - (a) regulate movement with the objective of preventing collisions between aircraft, and between aircraft and obstacles;
  - (b) regulate entry of aircraft into, and coordinate exit of aircraft from, the apron with the aerodrome control tower; and
  - (e) ensure safe and expeditious movement of vehicles and appropriate regulation of other activities.
- (2) Where the aerodrome control tower does not participate in the apron management service, procedures shall be established to facilitate the orderly transition of aircraft between the apron management unit and the aerodrome control tower.
- (3) An aerodrome operator shall ensure that, where an apron management service is established, radio telephony communication facilities are provided.
- (4) Where low visibility procedures are in effect, persons and vehicles operating in the apron shall be restricted to the essential minimum.

- (5) An emergency vehicle responding to an emergency shall have priority over all other surface movement traffic.
- (6) A vehicle operating on an apron shall:
  - (a) give way to an emergency vehicle; an aircraft taxiing, about to taxi, or being pushed or towed; and
  - (b) give way to other vehicles in accordance with local regulations.
- (7) An aircraft stand shall be visually monitored to ensure that the recommended clearance distances are provided to an aircraft using the stand.

#### **210. Ground Servicing of Aircraft**

- (1) An aerodrome operator shall ensure that fire extinguishing equipment, suitable for at least the initial intervention in the event of a fuel fire, is readily available during the ground servicing of an aircraft, and that there are means of quickly summoning the rescue and firefighting service in the event of a fire or major fuel spill.
- (2) An aerodrome operator shall ensure that, when aircraft refuelling operations take place while passengers are on board, embarking or disembarking, ground equipment are positioned in a manner that allows:
  - (a) the use of a sufficient number of exits for expeditious evacuation; and
  - (b) a ready escape route from each of the exits to be used in an emergency.

#### **211. Aerodrome Vehicle Operation**

- (1) A person shall not operate a vehicle on the manoeuvring area at an aerodrome where air traffic service is provided, except where authorized by the aerodrome control tower.
- (2) A person shall not operate a vehicle on an apron of an aerodrome except where authorized by the aerodrome operator.
- (3) A vehicle operating on the movement area shall have a rotating beacon.
- (4) A driver of the vehicle on the movement area shall comply with all mandatory instructions conveyed by markings and signs, where the vehicle is on the manoeuvring area, except where the driver is authorized by:
  - (a) the aerodrome control tower when on the manoeuvring area; and
  - (b) on an apron only as authorized by the appropriate designated authority
- (5) A driver of the vehicle on the movement area shall comply with all mandatory instructions conveyed by lights.
- (6) A driver of a vehicle on the movement area shall comply with all mandatory instructions conveyed by lights and instructions issued by the aerodrome control tower where the vehicle is on the manoeuvring area or by the appropriate designated authority, where the vehicle is on an apron.
- (7) A driver of a vehicle on the movement area shall be appropriately trained for the tasks to be performed and shall comply with the instructions issued by:
  - (a) the aerodrome control tower, when on the manoeuvring area; and
  - (b) the appropriate designated authority, when on the apron.

- (8) A driver of a radio-equipped vehicle shall establish satisfactory two-way radio communication with the aerodrome control tower before entering the manoeuvring area and with the appropriate designated authority before entering the apron, and shall maintain a continuous listening watch on the assigned frequency while on the movement area.

## **212. Surface Movement Guidance and Control Systems**

- (1) A surface movement guidance and control system (SMGCS) shall be provided at an aerodrome.
- (2) The design of an SMGCS provided at an aerodrome shall take into account:
  - (a) the density of air traffic;
  - (b) the visibility conditions under which operations are intended;
  - (c) the need for pilot orientation;
  - (d) the complexity of the aerodrome layout; and
  - (e) movements of vehicles.
- (3) The visual aid components of an SMGCS, that is, markings, lights and signs, shall be designed to conform with the relevant specifications in these regulations.
- (4) An SMGCS shall be designed to assist in the prevention of inadvertent incursions of aircraft and vehicles onto an active runway.
- (5) The system shall be designed to assist in the prevention of collisions between aircraft, and between aircraft and vehicles or objects, on any part of the movement area.
- (6) Where an SMGCS is provided by selective switching of stop bars and taxiway centre line lights, the following requirements shall be met:
  - (a) taxiway routes which are indicated by illuminated taxiway center line lights shall be capable of being terminated by an illuminated stop bar;
  - (b) the control circuits shall be so arranged that when a stop bar located ahead of an aircraft is illuminated, the appropriate section of taxiway center line lights beyond it is suppressed; and
  - (c) the taxiway center line lights are activated ahead of an aircraft when the stop bar is suppressed.
- (7) Surface movement radar for the manoeuvring area shall be provided at an aerodrome intended for use in runway visual range conditions less than a value of 350 m.
- (8) Minimum for the manoeuvring area shall be provided at an aerodrome other than that in sub-regulation (7) when traffic density and operating conditions are such that regularity of traffic flow cannot be maintained by alternative procedures and facilities.
- (9) This regulation shall apply to aerodromes in category A.

## **213. Siting of Equipment and Installations on Operational Areas**

- (1) Unless its function requires it to be there for air navigation or for aircraft safety purposes, no equipment or installation shall be:

- (a) on a runway strip, a runway end safety area, a taxiway strip or within the distances specified in Table 2, column 11, where it would endanger an aircraft; or
  - (b) on a clearway where it would endanger an aircraft in the air.
- (2) Any equipment or installation required for air navigation or for aircraft safety purposes which must be located:
- (a) on that portion of a runway strip within:
    - (i) 75 m of the runway center line where the code number is 3 or 4; or
    - (ii) 45 m of the runway center line where the code number is 1 or 2.
  - (b) on a runway end safety area, a taxiway strip or within the distances specified in Table 2; or
  - (c) on a clearway and which would endanger an aircraft in the air and shall be frangible and mounted as low as possible.
- (3) Any equipment or installation required for air navigation or for aircraft safety purposes which must be located on the non-graded portion of a runway strip shall be regarded as an obstacle and shall be frangible and mounted as low as possible.
- (4) Unless its function requires it to be there for air navigation or for aircraft safety purposes, no equipment or installation shall be located within 240 m from the end of the strip and within-
- (a) 60 m of the extended center line where the code number is 3 or 4;
  - (b) 45 m of the extended center line where the code number is 1 or 2 of a precision approach runway categories I, II or III.
- (5) Any equipment or installation required for air navigation or for aircraft safety purposes which must be located on or near a strip of a precision approach runway category I, II or III and which:
- (a) is situated within 240 m from the end of the strip and within-
    - (i) 60 m of the extended runway center line where the code number is 3 or 4; or
    - (ii) 45 m of the extended runway center line where the code number is 1 or 2; or
  - (b) penetrates the inner approach surface, the inner transitional surface or the balked landing surface shall be frangible and mounted as low as possible
- (6) Any equipment or installation required for air navigation or for aircraft safety purposes which are an obstacle of operational significance shall be frangible and mounted as low as possible.

#### **214. Fencing of Aerodromes and Installations**

- (1) An aerodrome operator of an aerodrome shall provide a fence or a suitable barrier on the Aerodrome.
  - (a) to prevent the entrance into the movement area, of any animals likely to be a hazard to aircraft; and

- (b) to deter the inadvertent or premeditated access of an unauthorised person onto a non- public area of the aerodrome.
- (2) An aerodrome operator shall provide suitable means of protection for an aerodrome to deter the inadvertent or premeditated access of unauthorised persons into ground installations and facilities essential for the safety of civil aviation located off the aerodrome.
- (3) The fence or barrier required under sub-regulation (1) shall be located so as to separate the movement area and other facilities or zones on the aerodrome which are vital to the safe operation of aircraft from areas open to public access.
- (4) Where greater security is needed, a cleared area shall be provided on both sides of the fence or barrier to facilitate the work of patrols and to make trespassing more difficult and provision for a perimeter road along the aerodrome fencing for the use of both maintenance personnel and security patrols shall be made.

**215. Security Lighting of Aerodrome Fence**

Where it is deemed desirable for security reasons, a fence or other barrier provided for the protection of international civil aviation and its facilities shall be illuminated at a minimum essential level and the security lighting shall be located so that the ground area on both sides of the fence or barrier, particularly at access points, is illuminated.

**216. Autonomous Runway Incursion Warning System (ARIWS)**

- (1) Where an ARIWS is installed at an aerodrome:
  - (a) it shall provide autonomous detection of a potential incursion or of the occupancy of an active runway and a direct warning to a flight crew or vehicle operator;
  - (b) it shall function and be controlled independently of any other visual system on the aerodrome;
  - (c) its visual aid components, including lights, shall be designed to conform with the relevant specifications in these Regulations; and
  - (d) failure of part or all of it shall not interfere with normal aerodrome operations. To this end, provision shall be made to allow the ATC unit to partially or entirely shut down the system.
- (2) It is intended that the system be operational under all weather conditions, including low visibility.
- (3) Where an ARIWS is installed at an aerodrome, information on its characteristics and status shall be provided to the Aeronautical Information Services for promulgation in the AIP with the description of the aerodrome surface movement guidance and control system and markings as specified in the applicable Civil Aviation (Aeronautical Information Services) Regulations.

**217. Maintenance of Safety Inspection Programme**

- (1) An aerodrome operator shall establish and maintain a safety inspection programme for the aerodrome.

- (2) The safety inspection programme shall:
  - (a) provide procedures to ensure that competent aerodrome personnel execute the program effectively; and
  - (b) provide a reporting system to ensure prompt correction of unsafe aerodrome conditions noted during any inspection.

**218. Access of Ground Vehicles to Aerodrome Movement Area**

- (1) An aerodrome operator shall:
  - (a) limit the access of any ground vehicles used for aerodrome and aircraft operations, to the aerodrome manoeuvring area;
  - (b) provide adequate procedures for the safe and orderly access to the aerodrome and operation in the manoeuvring area of ground vehicles, where an air traffic service unit is in operation at the aerodrome, in order to ensure that each ground vehicle operating in the aerodrome manoeuvring area is controlled by:
    - (i) two-way radio communication between the vehicle and the air traffic service unit; and
    - (ii) an accompanying radio communication or an escort vehicle with adequate measures including signals or guards to control the vehicle, where the vehicle does not have a radio.
  - (c) provide adequate measures to ensure that ground vehicles operating in the aerodrome movement area is controlled by signs, pre-arranged signals or guidelines prescribed by the Authority in the applicable technical guidance materials, where an air traffic service unit is not in operation at the aerodrome;
  - (d) ensure that any person who operates a ground vehicle on the aerodrome movement area is familiar with and complies with the aerodrome rules and procedures for the operation of ground vehicles as prescribed by the Authority in the technical guidance material.
- (2) An aerodrome operator shall ensure that a person who has access to the aerodrome movement area wears a coloured reflective gear which shall be conspicuously displayed while on the movement area.

**219. Supply of Aviation Fuel to Aircraft**

- (1) An operator of an aviation fuel installation at an aerodrome shall not cause or permit any aviation fuel to be delivered to that installation or from it, to an aircraft unless:
  - (a) when the aviation fuel is delivered to the installation, the operator of the aviation fuel installation is satisfied that:
    - (j) the installation is capable of storing and dispensing the fuel so as not to render it unfit for use in an aircraft;
    - (ii) the installation is marked in an appropriate manner to the grade of the fuel stored or where different grades are stored in different parts, that each part is so marked;
    - (iii) in the case of delivery into the installation or part of the installation from a vehicle or vessel, the fuel has been sampled and is of the grade

appropriate to that installation or part of the installation as the case may be and is fit for use in an aircraft;

- (b) when aviation fuel is dispensed from the installation, the operator of the aviation fuel installation is satisfied after sampling, that the fuel is fit for use in an aircraft.
- (2) A person shall not cause or permit aviation fuel to be dispensed for use in an aircraft where that person knows or has reason to believe that the aviation fuel is not fit for use in an aircraft.
  - (3) An aerodrome operator of an aviation fuel installation shall not on an aerodrome, supply fuel to an aircraft except at a place and in a manner approved by the operator.
  - (4) An aerodrome operator may subject to the approval granted under sub-regulation (3), ensure compliance with any conditions as the operator may impose, in order to safeguard persons or property on the ground.
  - (5) An aerodrome operator of an aviation fuel installation shall keep a written record in respect of each installation managed by that operator.
  - (6) The record in sub-regulation (5) shall include:
    - (a) particulars of the grade and quantity of aviation fuel delivered and the date of delivery;
    - (b) particulars of all samples taken of the aviation fuel and of the results of the tests of those samples; and
    - (c) particulars of the maintenance and cleaning of the installation.
  - (7) An operator of an aviation fuel installation shall preserve the written record for a period of twelve months or such longer period as the Authority may in a particular case direct and shall, within a reasonable time after being requested to do so by an authorised person, produce the record to that authorised person.
  - (8) The Authority or an authorised person may direct the operator of an aviation fuel installation not to permit aviation fuel to be dispensed from that installation until the direction is revoked by the Authority or that authorised person, where it appears to the Authority or to that authorised person that aviation fuel is intended or likely to be delivered in contravention of this regulation.
  - (9) For the purpose of this regulation:
    - (a) aviation fuel, means fuel intended for use in an aircraft; and
    - (b) aviation fuel installation, means any apparatus or container, including a vehicle designed manufactured or adapted for the storage of aviation fuel or for the delivery of fuel to an aircraft.

## CHAPTER XII AERODROME MAINTENANCE

### 220. Maintenance Programme

- (1) An aerodrome operator shall establish at the aerodrome, a maintenance programme, including preventive maintenance to maintain a facility in a condition that does not impair the safety, regularity and efficiency of air navigation.
- (2) In this regulation:  

**“Facility”** includes a pavement, visual aid, fencing, drainage system, electrical system and building; and

**“Preventive Maintenance”** means programmed maintenance work done to prevent failure or degradation of a facility.
- (3) The design and application of the maintenance programme shall observe Human Factors principles.

### 221. Maintenance of Pavements and Adjacent Areas

An aerodrome operator shall at all times ensure that:

- (1) the surfaces of all movement areas including pavements (runways, taxiways, and aprons) and adjacent areas are inspected and their conditions monitored regularly as part of an aerodrome preventive and corrective maintenance programme with the objective of avoiding and eliminating any foreign object debris (FOD) that might cause damage to aircraft or impair the operation of aircraft systems.
- (2) the surface of the runway is maintained in a condition that precludes formation of harmful irregularities such as water pools and rough surfaces.
- (3) a paved runway is to be maintained in a condition so as to provide surface friction characteristics at or above the minimum friction level specified by the Authority in table 1 below.
- (4) runway surface friction characteristics for maintenance purposes is periodically measured with a continuous friction measuring device using self-wetting features and documented and that the frequency of these measurements is sufficient to determine the trend of the surface friction characteristics of the runway.
- (5) when runway surface friction measurements are made for maintenance purposes using a self-wetting continuous friction measuring device, the performance of the device shall meet the standard set or agreed by the Authority, and the personnel measuring runway surface friction required shall be trained to fulfil their duties.
- (6) corrective maintenance action is taken to prevent the runway surface friction characteristics for either the entire runway or a portion thereof from falling below a minimum friction level specified by the Authority.
- (7) subject to paragraph (f) above, a portion of runway in the order of 100 m long may be considered significant for maintenance or reporting action.
- (8) when there is reason to believe that the drainage characteristics of a runway or portions of the runway, are poor due to slopes or depressions, then the runway friction

characteristics are assessed under natural or simulated conditions that are representative of local rain and corrective maintenance action is taken where necessary.

- (9) the runway surface shall be visually assessed, as necessary, under natural or simulated rain conditions for ponding or poor drainage and where required, corrective maintenance action taken.
- (10) where a taxiway is used by turbine-engine aeroplanes, the surface of the taxiway shoulders shall be maintained so as to be free of any loose stones or other objects that may be ingested by the aeroplane engines.

Test equipment	Test tire type	Test tire pressure (KPa)	Test speed (Km/h)	Test water depth (mm)	Design objective surface	Maintenance planning level	Minimum friction level
Mu-meter trailer	A	70	65	1.0	0,72	0,52	0,42
	A	70	95	1.0	0,66	0,38	0,26
Skiddometer Trailer	B	210	65	1.0	0,82	0,60	0,50
	B	210	95	1.0	0,74	0,47	0,34
Surface Friction Tester Vehicle	B	210	65	1.0	0,82	0,60	0,50
	B	210	95	1.0	0,74	0,47	0,34
Runway Friction Tester Vehicle	B	210	65	1.0	0,82	0,60	0,50
	B	210	95	1.0	0,74	0,54	0,41
TATRA Friction Tester Vehicle	B	210	65	1.0	0,76	0,57	0,48
	B	210	95	1.0	0,67	0,52	0,42
Grip Tester Trailer	C	140	65	1.0	0,74	0,53	0,43
	C	140	95	1.0	0,64	0,36	0,24

## **222. Removal of Contaminants**

- (1) Standing water, mud, dust, sand, oil, rubber deposits and other contaminants are removed from the surface of runways in use as rapidly and completely as possible to minimize accumulation.
- (2) Chemicals which may have harmful effects on aircraft or pavements, or chemicals which may have toxic effects on the aerodrome environment, shall not be used.

## **223. Maintenance of Runway Pavement Overlays**

- (1) The following specifications apply where a runway is to be returned temporarily to an operational status before resurfacing is complete during a runway pavement overlay project:
  - (a) The longitudinal slope of the temporary ramp when established between the new and old runway surfaces, measured with reference to the existing runway surface or previous overlay course, shall be:
    - (i) 0.5 to 1.0 per cent for overlays up to and including 5 cm in thickness; and
    - (ii) not more than 0.5 per cent for overlays more than 5 cm in thickness;
  - (b) Overlaying shall proceed from one end of the runway toward the other end so that based on runway utilization most aircraft operations shall experience a down ramp;
  - (c) The entire width of the runway shall be overlaid during each work session; and
  - (d) Before a runway being overlaid is returned to a temporary operational status, a runway centre line marking shall be provided and in addition, the location of any temporary threshold shall be identified by a 3.6 m wide transverse stripe;
- (2) An aerodrome operator shall ensure that, the overlay is constructed and maintained above the minimum friction level specified by the Authority.

## **224. Preventive Maintenance of Visual Aids**

- (1) An aerodrome operator shall not operate an aerodrome unless a system of preventive maintenance of visual aids is employed at the aerodrome.
- (2) The system of preventive maintenance of visual aids to be employed shall ensure lighting and marking system reliability.
- (3)
  - (a) A light shall be deemed to be unserviceable when the main beam average intensity is less than 50 per cent of the value specified in the appropriate figure in the Fourth Schedule to these regulations.
  - (b) For light units where the designed main beam average intensity is above the value shown in the Fourth Schedule to these regulations, the 50 per cent value shall be related to that design value.
- (4) The system of preventive maintenance employed for a precision approach runway category II or III shall include at least the following checks:

- (a) visual inspection and in-field measurement of the intensity, beam spread and orientation of lights included in the approach and runway lighting systems;
  - (b) control and measurement of the electrical characteristics of each circuitry included in the approach and runway lighting systems; and
  - (c) control of the correct functioning of light intensity settings used by air traffic control.
- (5) The in-field measurements of intensity, beam spread and orientation of lights included in approach and runway lighting systems for a precision approach runway category II or III shall be undertaken by measuring all lights, as far as practicable, to ensure conformance with the applicable specification of in the Fourth Schedule to these regulations.
- (6) Measurement of intensity, beam spread and orientation of lights included in approach and runway lighting systems for a precision approach runway category II or III shall be undertaken using a mobile measuring unit of sufficient accuracy to analyse the characteristics of the individual lights.
- (7) The frequency of measurement of lights for a precision approach runways categories II or III shall be based on traffic density, the local pollution level, the reliability of installed lighting equipment and the continuous assessment of the result of the in-field measurements but, in any event, shall not be less than twice a year for in-pavement lights and not less than once a year for other lights.
- (8) The system of preventive maintenance employed for a precision approach runway category II or III shall have as its objective that, during any period of category II or III operations, all approach and runway lights are serviceable and that, in any event, at least:
- (a) 95 per cent of the lights are serviceable in each of the following particular significant elements:
    - (i) precision approach category II and III lighting system, the inner 450 m;
    - (ii) runway center line lights;
    - (iii) runway threshold lights; and
    - (iv) runway edge lights;
  - (b) 90 per cent of the lights are serviceable in the touchdown zone lights;
  - (c) 85 per cent of the lights are serviceable in the approach lighting system beyond 450 m; and
  - (d) 75 per cent of the lights are serviceable in the runway end lights. In order to provide continuity of guidance, the allowable percentage of unserviceable lights shall not be permitted in such a way as to alter the basic pattern of the lighting system. Additionally, an unserviceable light shall not be permitted adjacent to another unserviceable light, except in a barrette or a crossbar where two adjacent unserviceable lights may be permitted.
- (9) With respect to barrettes, crossbars and runway edge lights, lights are considered to be adjacent where located consecutively and:
- (a) laterally: in the same barrette or crossbar; or

- (b) longitudinally: in the same row of edge lights or barrettes.
- (10) The system of preventive maintenance employed for a stop bar provided at a runway-holding position used in conjunction with a runway intended for operations in runway visual range conditions less than a value of 350 m shall have the following objectives:
  - (a) no more than two lights shall remain unserviceable; and
  - (b) two adjacent lights shall not remain unserviceable unless the light spacing is significantly less than that specified.
- (11) The system of preventive maintenance employed for a taxiway intended for use in runway visual range conditions less than a value of 350 m shall have as its objective that no two adjacent taxiway centre line lights be unserviceable.
- (12) The system of preventive maintenance employed for a precision approach runway category I shall have as its objective that, during any period of category I operations, all approach and runway lights are serviceable and that, in any event, at least 85 per cent of the lights are serviceable in each of the following:
  - (a) precision approach category I lighting system;
  - (b) runway threshold lights;
  - (c) runway edge lights; and
  - (d) runway end lights. In order to provide continuity of guidance an unserviceable light shall not be permitted adjacent to another unserviceable light unless the light spacing is significantly less than that specified.
- (13) The system of preventive maintenance employed for a runway meant for take-off in runway visual range conditions less than a value of 550 m shall have as its objective that, during any period of operations, all runway lights are serviceable and that in any event:
  - (a) at least 95 per cent of the lights are serviceable in the runway center line lights (where provided) and in the runway edge lights; and
  - (b) at least 75 per cent of the lights are serviceable in the runway end lights. In order to provide continuity of guidance, an unserviceable light shall not be permitted adjacent to another unserviceable light.
- (14) The system of preventive maintenance employed for a runway meant for take-off in runway visual range conditions of a value of 550 m or greater shall have as its objective that, during any period of operations, all runway lights are serviceable and that, in any event, at least 85 per cent of the lights are serviceable in the runway edge lights and runway end lights. In order to provide continuity of guidance, an unserviceable light shall not be permitted adjacent to another unserviceable light.
- (15) During low visibility procedures the appropriate authority shall restrict construction or maintenance activities in the proximity of aerodrome electrical systems.

## **225. Construction or Maintenance Activity During Low Visibility Operations**

An aerodrome operator shall ensure that any construction or maintenance activity is not undertaken in the proximity of aerodrome electrical systems at any time during periods of low visibility operations.

## **226. Works at Aerodromes**

- (1) An operator shall establish procedures and precautions to ensure that any works carried out at an aerodrome do not endanger the safety of any aircraft operations.
- (2) The procedures and precautions in sub-regulation (1) shall comply with guidelines prescribed by the Authority in the applicable technical guidance materials.

## **CHAPTER XIII GENERAL PROVISIONS**

### **227. Application for Exemption Aeronautical Study**

- (1) A person may apply in writing to the Authority for an exemption from specific provision of these regulations in accordance with part ...7 the South Sudan Civil Aviation Certification, Licensing and Registration of Aerodrome Regulations.
- (2) Where an aerodrome does not meet the requirements of these regulations, the Authority may determine, after an aeronautical study, the conditions and procedures that are necessary to ensure a level of safety equivalent to that established by the relevant regulations. Subject to sub regulation (1), the aerodrome operator shall conduct an aeronautical study, and submit the report to the authority for review.

### **228. Deviations from These Regulations**

Any deviation from these Regulations shall be set out in an endorsement on the aerodrome certificate, license and in the aerodrome manual.

### **229. Safety Inspections and Audits**

The Authority shall:

- (a) carry out such safety inspections and audits as may be necessary for the purpose of verifying the validity of an application for construction and operation of an aerodrome;
- (b) carry out safety inspections and audits of any document and records of an operator, which may be necessary to determine compliance with the appropriate requirements as prescribed in these Regulations

### **230. Enforcement**

- (1) The Authority shall take enforcement action on any regulated entity that fails to comply with the provisions of these regulations.
- (2) Inspectors of the Authority holding valid delegations shall take necessary action to preserve safety where an undesirable condition has been detected.
- (3) The action(s) referred to in sub-regulation (2) may include:
  - (a) In the case of a regulated entity, imposition of operating restrictions until such a time that the existing undesirable condition has been resolved;

- (b) In carrying out the enforcement actions pursuant to the provisions of sub-regulation (2), the inspectors of the Authority shall invoke the powers with due care and act in good faith in the interest of preserving safety.
- (4) Inspectors of the Authority holding valid delegations shall take necessary action to preserve safety where an undesirable condition has been detected

**231. Contravention of Regulations**

A person who contravenes any provision of these Regulations may have his certificate, licence, approval, authorisation or such other document suspended or revoked.

**CHAPTER XIV  
MISCELLANEOUS PROVISIONS**

**232. Savings and Transition**

A licence, certificate, approval or any other document issued to an operator prior to the commencement of these Regulations shall continue in force as where it was issued under these Regulations until it expires or is cancelled by the Authority or a court of competent jurisdiction.

**233. Revocation**

The South Sudan Civil Aviation “Aerodromes Design and Regulation Regulations, 2025” is repealed.

**234. Offences and Penalties**

- (1) A person who contravenes any provision of these Regulations, orders or notices commits an Offence and upon conviction, shall be sentence to imprisonment for a term not exceeding six (6) month or a fine or both.
- (2) In the case of a continuing contravention, each day of the contravention shall constitute a separate offence and shall be liable to an additional fine for each day the offence continues.
- (3) Where it is proved that an act or omission of any person, which have been a contravention by that person of a provision of these Regulations, orders or notices made there under was due to any cause not avoidable by the exercise of reasonable care by that person, the act or omission shall be deemed not to be a contravention by that person of that provision.

## **FIRST SCHEDULE**

### **(Regulation 5)**

#### **CHAPTER A**

#### **SYSTEMATIC MANAGEMENT OF SAFETY AT AERODROMES**

##### **1. Safety Management**

All aerodromes shall establish and implement a system for managing safety at the aerodrome commensurate with the size and complexity of the aerodrome.

##### **2. Interpretation**

In this Schedule, unless the context otherwise requires:

“**Risk**” is the combination of the probability, or frequency of occurrence of a defined hazard and the magnitude of the consequences of the occurrence.

##### **3. Safety Objective**

An aerodrome and the facilities, equipment and systems of the aerodrome shall be designed and operated such that for any hazard, the combination of the probability of occurrence and the seriousness of the consequences of the hazard occurring must not result in a level of risk that is unacceptable.

##### **4. Safety Management Policy Statements**

Safety Management Systems (SMS) established at aerodromes shall include the following:

- (a) a statement that the highest priority shall be attached to safety in relations to all business activities;
- (b) a business objective for safety that shall minimize the aerodrome’s contribution to aviation accidents risk to as low as reasonably practicable;
- (c) a commitment by the aerodrome operator to adopt an explicit and pro-active approach to safety management.
- (d) statements of safety-related responsibilities and accountabilities at all levels of the organization;
- (e) a commitment to comply with all appropriate safety standards;
- (f) a commitment that the safety assurance processes used by external suppliers comply with safety standards and requirements;
- (g) an emergency response plan that provides for the orderly and efficiency transition and coordination of operations from normal to emergency and back to normal.

##### **5. Safety Management Principles**

###### **(1)**

- (a) Whenever practicable, quantitative safety levels shall be derived, maintained and improved for all aviation products and services delivered by the

aerodrome; and when quantitative safety levels cannot be derived, a qualitative reasoning shall be performed in order to meet the safety objective.

- (b) An operator shall assess all existing operations, proposed changes, additions or replacements for their safety significance.
- (c) An operator shall identify and record the safety requirements for a service or product, the results of the safety assessment process and the evidence that the safety requirements have been met, and the records shall be maintained throughout the life of the service or product.
- (d) An operator shall ensure that personnel whose functions impact on safety at the aerodrome are adequate, trained and qualified for the job they are required to do and for which they have accountability.

(2)

- (a) An operator shall ensure that there is accountability, at a suitable senior level for the management, development and monitoring of the safety management system.
- (b) An operator shall routinely carry out internal safety audits to provide assurance of the safety activities and to confirm compliance with the safety requirements and the safety management system.
- (c) An operator shall have in place suitable monitoring arrangements so that undesirable trends in service or product performance can be recognized and be subject to remedial action; and in order to achieve this, the operator shall in accordance with the provisions of the Part B of this Schedule:
  - (i) establish a reporting system for accident and incident reporting that ensures the Authority is informed of the aviation safety aspects in connection with the aerodrome; and
  - (ii) investigate safety significant occurrences, identify any failures of its management of safety and take corrective action where required;
- (d) The operator shall establish and maintain procedures, which enable tracing of documents and data related to the safety management system, and the procedures shall ensure that all safety related documents and data are available, and that invalid documents and data shall be destroyed and secured against unintended use.

**6. Safety Management Strategy**

- (1) An operator shall establish processes to identify safety shortcomings, so that remedial action can be taken to ensure safety levels are maintained.
- (2) The basic principles to be applied in the safety management strategy shall include:
  - (a) safety achievement; specifying the means by which the safety performance of the organization meets its safety objectives and derived requirements;
  - (b) safety assurance; specifying the means for providing assurance that risks are

- being managed properly and effectively;
    - (c) safety performance monitoring and measurement; specifying the means to verify safety performance of the organisation and to validate the effectiveness of safety risk controls;
    - (d) safety promotion; specifying the means by which safety issues are communicated within the aerodrome to eliminate unnecessary risks and avoid repeat errors or risks and safety training programme that ensures personnel are trained and competent to perform SMS duties.
  - (3) An operator shall develop and maintain a formal process to:
    - (a) ensure that hazards in operations are identified;
    - (b) identify changes within the organisation which may affect processes and services and shall describe arrangements to ensure safety performance before implementing changes; and
    - (c) identify the causes of substandard performance of safety management systems, determine the implications of substandard performance of the SMS in operation and eliminate or mitigate such processes.

## **7. Operational Safety Assurances Documentation**

An operator shall produce and maintain safety assurance documentation, and this documentation shall cover:

- (a) all safety related roles and functions;
- (b) a safety-based risk assessment of the roles and functions where practicable;
- (c) a process of risk management for safety related tasks and functions to ensure that identified risks remain tolerable;
- (d) safety performance measurements of the current operations as part of the ongoing risk management; and
- (e) corrective procedures and measures that modify the original tasks or functions to address inadequate performance.

## **8. Safety Assurance Documentation on Systems Requiring Approval**

- (1) An operator shall, when intending to introduce new systems into operation, or introduce changes to, or replace existing systems, submit an application for approval by the Authority.
- (2) The aerodrome operator shall also submit an application for approval where the intended changes affect the approvals in the aerodrome license.
- (3) An aerodrome operator shall, where satisfied that their own safety requirements as well as those issued by the Authority have met the compliance criteria, notify the Authority in writing indicating compliance with the specified safety requirements for any operational system.

## **9. Safety Assessment Methodology**

The safety assessment of the aerodrome shall involve:

- (a) systematic identification of possible hazards to aircraft;
- (b) evaluation of the seriousness of the consequences of the hazard occurring;
- (c) considering the chances of a hazard happening;
- (d) determining whether the consequent risk is tolerable and within the operator's acceptable safety performance criteria; and
- (e) taking action to reduce the severity of the hazard or the probability of it arising in order to reduce the risk to a tolerable level.

**10. Safety Auditing of Aerodromes**

An operator shall carry out internal safety auditing of the aerodrome in order to determine -

- (a) the level of compliance with requirements;
- (b) the areas and degree of risk and their effective management; and
- (c) the competence and performance of those responsible for safety.

**CHAPTER B**

**AIRCRAFT ACCIDENT AND INCIDENT REPORTING AND INVESTIGATION AT AERODROMES**

**1. Aerodrome Occurrence Reporting**

- (1) This schedule prescribes the requirements for reporting the occurrence or detection of defects, failures or malfunctions at an aerodrome, its components or equipment, which may jeopardize the safe operation of the aerodrome or cause it to become a danger to persons or property.
- (2) The objectives of the aerodrome occurrence reports are as follows:
  - (a) to ensure that knowledge of these occurrences is disseminated so that other persons and organizations may learn from them; and
  - (b) to enable an assessment to be made by those concerned (whether internal or external to the aerodrome operator) of the safety implications of each occurrence, both in itself and in relation to previous similar occurrences, so that they may take or initiate any necessary action.

**2. Reportable Occurrences and Reporting Procedures**

- (1) An operator shall notify the Authority of any accident, serious incident, fatal or serious injury occurring at the aerodrome as soon as practicable after the occurrence and provide a detailed occurrence report thereafter.
- (2) For the purpose of this Schedule:
  - (a) **“Accident”** means an occurrence associated with the operation of an aircraft, which takes place between the time any person boards the aircraft with the

intention of flight until such time as all such persons have disembarked, in which:

- (i) a person is fatally or seriously injured as a result of:
    - (aa) being in the aircraft, or
    - (bb) direct contact with any part of the aircraft, including parts which have become detached from the aircraft, or
    - (cc) direct exposure to jet blast, except when the injury is from natural causes, self-inflicted, or inflicted by other persons, or when the injuries are to stowaways hiding outside the areas normally available to the passengers and crew or;
  - (ii) the aircraft sustains damage or structural failure which:
    - (aa) adversely affects the structural strength, performance or flight characteristics of the aircraft; and
    - (bb) shall normally require major repair or replacement of the affected component except for engine failure or damage, when the damage is limited to the engine, its cowlings or accessories; or for damage limited to propellers, wing tips, antennas, tires, brakes, fairings, small dents or puncture holes in the aircraft skin; or
  - (iii) the aircraft is missing or is completely inaccessible.
- (b) **“Serious Incident”** includes:
- (i) a near collision requiring avoidance manoeuvre to avoid a collision or an unsafe situation or where an avoidance action shall have been appropriate;
  - (ii) a controlled flight into terrain only marginally avoided;
  - (iii) an aborted take-off on a closed or engaged runway;
  - (iv) a take-off from a closed or engaged runway with marginal separation from an obstacle;
  - (v) a landing or attempted landing on a closed or engaged runway;
  - (vi) a take-off or landing incident such as undershooting; or overrunning or running off the side of runways; or
  - (vii) a major failure of any navigation aid when a runway is in use;
- (c) **“Serious injury”** means any injury that is sustained by a person in an accident and that:
- (i) requires hospitalization for more than forty-eight hours, commencing within seven days from the date the injury was received;
  - (ii) results in a fracture of any bone, except simple fractures of fingers, toes or nose;
  - (iii) involves lacerations which cause severe hemorrhage, nerve, muscle, or tendon damage;

- (iv) involves any injury to any internal organ;
  - (v) involves second- or third-degree burns, or any burns affecting more than 5% of the body surface; or
  - (vi) involves verified exposure to infectious substances or injurious radiation.
- (3) The operator shall notify the Aircraft Accident and Incident Investigation Branch whenever an accident or serious incident occurs on or adjacent to his aerodrome in accordance with the provisions of the South Sudan Civil Aviation (Aircraft Accident and Incident Investigation) Regulations.
- (4) Information to be provided in the reporting and notification of an accident, serious incident or serious injury shall as far as possibly include the following -
- (a) the date and local time of occurrence;
  - (b) the exact location of the occurrence with reference to some easily defined geographical point;
  - (c) detailed particulars of the parties involved, including the owner, operator, manufacturer, nationality, registration marks, serial numbers, assigned identities of aircraft and equipment;
  - (d) a detailed description of the sequence of events leading up to the incident;
  - (e) the physical characteristics, environment or circumstances of the area in which the incident occurred and an indication of the access difficulties or special requirements to reach the site;
  - (f) the identification of the person sending the notice and where the incident occurred;
  - (g) in the case of an aircraft accident, the number of crew members, passengers or other persons respectively killed or seriously injured as a result of the accident; and
  - (h) a description of the follow-up action being taken after the incident has occurred.

### **3. Aerodrome Occurrence Records**

- (1) An operator shall establish and maintain aerodrome occurrence reports for any accident, serious incident, serious injury or any occurrence or event that has a bearing on the safety of aerodrome operations.
- (2) An operator shall use aerodrome occurrence reports to monitor and improve the level of operational safety, including reviews of safety standards required.
- (3) The Authority may require the operator to produce and provide information contained in the aerodrome occurrence report relating to any safety occurrence or event.

#### **4. Aircraft Accident and Incident Investigation**

- (1) In the event of an accident or serious incident, an operator shall carry out its own investigations.
- (2) The investigations carried out by the aerodrome operator shall be additional to that carried out by the Aircraft Accident and Incident Investigation Branch to enable the operator to assess safety of aircraft operations at his aerodrome.
- (3) The investigator, or team of investigators, shall be technically competent and shall either possess or have access to the background information, so that the facts and events are interpreted accurately. The investigations shall be a search to establish how the mishap happened, why it occurred, including organizational contributing factors, and to recommend action to prevent a recurrence, and shall not be intended to apportion blame.
- (4) The lesson learnt derived from an aerodrome incident or accident investigation shall be disseminated to personnel to provide feedback for safety improvement.
- (5) The Authority may require the operator to produce and provide information contained in the aerodrome accident or incident investigation report relating to any such event.
- (6) An operator shall inspect his aerodrome, as circumstances require, to ensure safety as soon as practicable after any aircraft accident or incident.

## **SECOND SCHEDULE**

### **Regulation 72**

#### **SHIELDING OF OBSTACLES**

##### **1. General**

- 1.1 The principle of shielding as applied to obstacles to air navigation may reduce the necessity for removing obstacles or prohibiting the construction of new constructions.
- 1.2 Shielding principles are employed when some object, an existing building or natural terrain already penetrates above one of the obstacle limitations surfaces.

##### **2. The Principles of Shielding**

- 2.1 Where it is considered that the nature of an object is such that its presence may be described as permanent, the additional objects within a specified area around it may be permitted to penetrate the surface without being considered as obstacles. The original obstacle is considered as dominating or shielding the surrounding area.

- 2.2 The formula for shielding shall be based on a horizontal plane projected from the top of each obstacle away from the runway and a plane with a negative slope of 10% towards the runway. Any object which is below either of the two planes shall be considered shielded. The permission to allow objects to penetrate an obstacle limitation surface under the shielding principle shall however be qualified by reference to the need for an aeronautical study in all cases.
- 2.3 The shielding effect of immovable obstacles laterally in approach and take-off climb shall be more critically considered. It is important to preserve existing unobstructed cross section areas particularly when the obstacle is close to the runway. This shall guard against future changes in either approach or take-off climb area specifications or the adoption of a turned take-off procedure.
- 2.4 An object shall be considered as permanent and immovable obstacle only if, when taking the longest view possible, there is no prospect of removal being practicable, possible or justifiable, regardless of how the pattern, type or density of air operations might change. Generally, an aeronautical study shall need to be carried out to determine the exact effect the construction of a new object shall have on air operations.

### **3. Alternative Methods for Assessing Obstacles in Critical Areas**

The Authority may assess and determine whether an obstacle is shielded. In assessing whether an existing obstacle shields other obstacles, the Authority may be guided by the following shielding practices:

#### **3.1 Obstacles in the Take-off climb and Approach Surfaces**

An obstacle may be assessed as not imposing additional restrictions if:

- (a) when located between the inner edge end and the critical obstacle, the obstacle being assessed is below a plane sloping downwards at 10% from the top of the critical obstacle toward the inner edge.
- (b) when located beyond the critical obstacle from the inner edge end, the obstacle being assessed is not higher than the height of the permanent obstacle; and
- (c) where there is more than one critical obstacle within the approach and take-off climb area, and the obstacle being assessed is located between two critical obstacles, the height of the obstacle being assessed is not above a plane sloping downwards at 10% from the top of the next critical obstacle.

#### **3.2 Obstacle in the Transitional Surfaces**

An obstacle may be assessed as not imposing additional restrictions where it does not exceed the height of an existing obstacle which is closer to the runway strip and the obstacle being assessed is located perpendicularly behind the existing obstacle relative to the runway center line.

**Figure 4-3 – Shielding of Obstacles Penetrating the Approach and Take-Off Climb Surfaces**

### 3.3 Obstacle in the Horizontal and Conical Surfaces

An obstacle may be assessed as not imposing additional restrictions where it is in the vicinity of an existing obstacle, and does not penetrate a 10% downward sloping conical shaped surface from the top of the existing obstacle, i.e. the obstacle is shielded radially by the existing obstacle

## THIRD SCHEDULE

### Regulation 79, 147,

## COLOURS FOR AERONAUTICAL GROUND LIGHTS, MARKINGS, SIGNS AND PANELS

### 1. General

Introductory Note. — The following specifications define the chromaticity limits of colours to be used for aeronautical ground lights, markings, signs and panels. The specifications are in accord with the 1983 specifications of the International Commission on Illumination (CIE), except for the colour orange in Figure A1-2.

It is not possible to establish specifications for colours such that there is no possibility of confusion. For reasonably certain recognition, it is important that the eye illumination be well above the threshold of perception, that the colour not be greatly modified by elective atmospheric attenuations and that the observer's colour vision be adequate. There is also a risk of confusion of colour at an extremely high level of eye illumination such as may be obtained from a high-intensity source at very close range. Experience indicates that satisfactory recognition can be achieved where due attention is given to these factors.

The chromaticity's are expressed in terms of the standard observer and coordinate system adopted by the International Commission on Illumination (CIE) at its Fourth Session at Cambridge, England, in 1931. \*

The chromaticity's for solid state lighting (e.g. LED) are based upon the boundaries given in the standard S 004/E-2001 of the International Commission on Illumination (CIE), except for the blue boundary of white.

### 2. Colors for Aeronautical Ground Lights

2.1 Chromaticities for lights having filament-type light sources

2.1.1 The chromaticity's of aeronautical ground lights shall be within the following boundaries:

CIE Equations (see Figure A1-1):

(a) Red

Purple boundary  $y = 0.980 - x$

Yellow boundary  $y = 0.335$ , except for visual approach slope indicator systems

Yellow boundary  $y = 0.320$ , for visual approach slope indicator systems

Note: See Regulation .....

(b) Yellow

Red boundary  $y = 0.382$

White boundary  $y = 0.790 - 0.667x$

Green boundary  $y = x - 0.120$

(c) Green

Yellow boundary  $x = 0.360 - 0.080y$

White boundary  $x = 0.650y$

Blue boundary  $y = 0.390 - 0.171x$

(d) Blue

Green boundary  $y = 0.805x + 0.065$

White boundary  $y = 0.400 - x$

Purple boundary  $x = 0.600y + 0.133$

(e) White

Yellow boundary  $x = 0.500$

Blue boundary  $x = 0.285$

Green boundary  $y = 0.440$  and  $y = 0.150 + 0.640x$

Purple boundary  $y = 0.050 + 0.750x$  and  $y = 0.382$

(f) Variable White

Yellow boundary  $x = 0.255 + 0.750y$  and  $y = 0.790 - 0.667x$

Blue boundary  $x = 0.285$

Green boundary  $y = 0.440$  and  $y = 0.150 + 0.640x$

Purple boundary  $y = 0.050 + 0.750x$  and  $y = 0.382$

2.1.2 Where dimming is not required, or where observers with defective colour vision must be able to determine the colour of the light, green signals shall be within the following boundaries:

Yellow boundary  $y = 0.726 - 0.726x$

White boundary  $x = 0.650y$

Blue boundary  $y = 0.390 - 0.171x$

2.1.3 Where increased certainty of recognition is more important than maximum visual range, green signals shall be within the following boundaries:

Yellow boundary  $y = 0.726 - 0.726x$

White boundary  $x = 0.625y - 0.041$

Blue boundary  $y = 0.390 - 0.171x$

2.2 Discrimination between lights having filament-type sources

- 2.2.1 Where there is a requirement to discriminate yellow and white from each other, they shall be displayed in close proximity of time or space as, for example, by being flashed successively from the same beacon.
- 2.2.2 Where there is a requirement to discriminate yellow from green and/or white, as for example on exit taxiway centre line lights, the y coordinates of the yellow light shall not exceed a value of 0.40.
- Note: The limits of white have been based on the assumption that they shall be used in situations in which the characteristics (colour temperature) of the light source shall be substantially constant.
- Note: The limits of white have been based on the assumption that they will be used in situations in which the characteristics (colour temperature) of the light source will be substantially constant.
- 2.2.3 The colour variable white is intended to be used only for lights that are to be varied in intensity, e.g., to avoid dazzling. Where this colour is to be discriminated from yellow, the lights shall be so designed and operated that:
- the x coordinate of the yellow is at least 0.050 greater than the x coordinate of the white; and
  - the disposition of the lights shall be such that the yellow lights are displayed simultaneously and in close proximity to the white lights.
- 2.3 Chromaticity's for lights having a solid-state light source
- 2.3.1 The chromaticity's of aeronautical ground lights with solid state light sources, e.g. LEDs, shall be within the following boundaries:
- CIE Equations (see Figure A1-1b):
- Red
    - Purple boundary  $y = 0.980 - x$
    - Yellow boundary  $y = 0.335$ , except for visual approach slope indicator systems
    - Yellow boundary  $y = 0.320$ , for visual approach slope indicator systems
    - Note: See regulation () and (12).
  - Yellow
    - Red boundary  $y = 0.387$
    - White boundary  $y = 0.980 - x$
    - Green boundary  $y = 0.727x + 0.054$
  - Green (also refer to 2.3.2 and 2.3.3)
    - Yellow boundary  $x = 0.310$
    - White boundary  $x = 0.625y - 0.041$
    - Blue boundary  $y = 0.400$
  - Blue
    - Green boundary  $y = 1.141x - 0.037$

White boundary  $y = 0.400 - y$   
Purple boundary  $x = 0.134 + 0.590y$

(e) White

Yellow boundary  $x = 0.440$   
Blue boundary  $x = 0.320$  Green boundary  $y = 0.150 + 0.643x$   
Purple boundary  $y = 0.050 + 0.757x$

(f) Variable white

The boundaries of variable white for solid state light sources are those of e) White above.

2.3.2 Where observers with defective colour vision must be able to determine the colour of the light, green signals should be within the following boundaries:

Yellow boundary  $y = 0.726 - 0.726x$   
White boundary  $x = 0.625y - 0.041$   
Blue boundary  $y = 0.400$

2.3.3 In order to avoid a large variation of shades of green, where colours within the boundaries below are selected, colours within the boundaries of 2.3.2 should not be used.

Yellow boundary  $x = 0.310$   
White boundary  $x = 0.625y - 0.041$   
Blue boundary  $y = 0.726 - 0.726x$

2.4 Colour measurement for filament-type and solid state-type light sources

2.4.1 The colour of aeronautical ground lights shall be verified as being within the boundaries specified in Figure A1-1 by measurement at five points within the area limited by the innermost iso candela curve (iso candela diagrams in Fourth Schedule refer), with operation at rated current or voltage. In the case of elliptical or circular iso candela curves, the colour measurements shall be taken at the centre and at the horizontal and vertical limits. In the case of rectangular iso candela curves, the colour measurements shall be taken at the centre and the limits of the diagonals (corners). In addition, the colour of the light shall be checked at the outermost iso candela curve to ensure that there is no colour shift that might cause signal confusion to the pilot.

Note 1: For the outermost iso candela curve, a measurement of colour coordinates shall be made and recorded for review and judgment of acceptability by the appropriate authority.

Note 2: Certain light units may have application so that they may be viewed and used by pilots from directions beyond that of the outermost iso candela curve (e.g. stop bar lights at significantly wide runway-holding positions). In such instances, the appropriate authority shall assess the actual application and where necessary, require a check of colour shift at angular ranges beyond the outermost curve.

2.4.2 In the case of visual approach slope indicators and other light units having a colour transition sector, the colour shall be measured at points in accordance with 2.4.1 above, except that the colour areas shall be treated separately and no point shall be within 0.5 degrees of the transition sector.

### 3. Colors for Markings, Signs and Panels

Note 1: The specifications of surface colours given below apply only to freshly coloured surfaces. Colours used for markings, signs and panels usually change with time and therefore require renewal.

Note 2: Guidance on surface colours is contained in the CIE document entitled Recommendations for Surface Colours for Visual Signalling — Publication No. 39-2 (TC-106) 1983.

Note 3: The specifications recommended in 3.4 below for trans illuminated panels are interim in nature and are based on the CIE specifications for trans illuminated signs. It is intended that these specifications shall be reviewed and updated as and when CIE develops specifications for trans illuminated panels.

3.1 The chromaticity's and luminance factors of ordinary colours, colours of retro-reflective materials and colours of trans illuminated (internally illuminated) signs and panels shall be determined under the following standard conditions:

- (a) angle of illumination: 45°;
- (b) direction of view: perpendicular to surface; and
- (c) illuminant : CIE standard illuminant D<sub>65</sub>.

3.2 The chromaticity and luminance factors of ordinary colours for markings and externally illuminated signs and panels shall be within the following boundaries when determined under standard conditions.

CIE Equations (see Figure A1-2):

(a) Red

Purple boundary	$y = 0.345 - 0.051x$
White boundary	$y = 0.910 - x$
Orange boundary	$y = 0.314 + 0.047x$
Luminance factor	$\beta = 0.07$ (mm)

(b) Orange

Red boundary	$y = 0.285 + 0.100x$
White boundary	$y = 0.940 - x$
Yellow boundary	$y = 0.250 + 0.220x$
Luminance factor	$\beta = 0.20$ (mm)

(c) Yellow

Orange boundary	$y = 0.108 + 0.707x$
White boundary	$y = 0.910 - x$
Green boundary	$y = 1.35x - 0.093$
Luminance factor	$\beta = 0.45$ (mm)

(d)	White	
	Purple boundary	$y = 0.010 + x$
	Blue boundary	$y = 0.610 - x$
	Green boundary	$y = 0.030 + x$
	Yellow boundary	$y = 0.710 - x$
	Luminance factor	$\beta = 0.75$ (mm)

(e)	Black	
	Purple boundary	$y = x - 0.030$
	Blue boundary	$y = 0.570 - x$
	Green boundary	$y = 0.050 + x$
	Yellow boundary	$y = 0.740 - x$
	Luminance factor	$\beta = 0.03$ (max)

(f)	Yellowish green	
	Green boundary	$y = 1.317x + 0.4$
	White boundary	$y = 0.910 - x$
	Yellow boundary	$y = 0.867x + 0.4$

(g)	Green	
	Yellow boundary	$x = 0.313$
	White boundary	$y = 0.243 + 0.067x$
	Blue boundary	$y = 0.493 - 0.524x$
	Luminance factor	$\beta = 0.10$ (mm)

Note: The small separation between surface red and surface orange is not sufficient to ensure the distinction of these colours when seen separately.

3.3 The chromaticity and luminance factors of colours of retro-reflective materials for markings, signs and panels shall be within the following boundaries when determined under standard conditions.

CIE Equations (see Figure A1-3):

(a)	Red	
	Purple boundary	$y = 0.345 - 0.051x$
	White boundary	$y = 0.910 - x$
	Orange boundary	$y = 0.314 + 0.047x$
	Luminance factor	$\beta = 0.03$ (mm)

(b)	Orange	
	Red boundary	$y = 0.265 + 0.205x$
	White boundary	$y = 0.910 - x$
	Yellow boundary	$y = 0.207 + 0.390x$
	Luminance factor	$\beta = 0.14$ (mm)

(c)	Yellow	
	Orange boundary	$y = 0.160 + 0.540x$
	White boundary	$y = 0.910 - x$

	Green boundary	$y = 1.35x - 0.093$
	Luminance factor	$\beta = 0.16$ (mm)
(d)	White	
	Purple boundary	$y = x$
	Blue boundary	$y = 0.610 - x$
	Green boundary	$y = 0.040 + x$
	Yellow boundary	$y = 0.710 - x$
	Luminance factor	$\beta = 0.27$ (mm)
(e)	Blue	
	Green boundary	$y = 0.118 + 0.675x$
	White boundary	$y = 0.370 - x$
	Purple boundary	$y = 1.65x - 0.187$
	Luminance factor	$\beta = 0.01$ (mm)
(f)	Green	
	Yellow boundary	$y = 0.711 - 1.22x$
	White boundary	$y = 0.243 + 0.670x$
	Blue boundary	$y = 0.405 - 0.243x$
	Luminance factor	$\beta = 0.03$ (mm)

3.4 The chromaticity and luminance factors of colours for trans-illuminated (internally illuminated) signs and panels shall be within the following boundaries when determined under standard conditions.

CIE Equations (see Figure A1-4):

(a)	Red	
	Purple boundary	$y = 0.345 - 0.051x$
	White boundary	$y = 0.910 - x$
	Orange boundary	$y = 0.314 + 0.047x$
	Luminance factor	$\beta = 0.07$ (mm)
	(Day condition)	
	Relative luminance to white (night condition)	5% (mm) 20% (max)
(b)	Yellow	
	Orange boundary	$y = 0.108 + 0.707x$
	White boundary	$y = 0.910 - x$
	Green boundary	$y = 1.35x - 0.093$
	Luminance factor	$\beta = 0.45$ (mm)
	(Day condition)	
	Relative luminance to white (night condition)	30% (mm) 80% (max)
(c)	White	

Purple boundary  $y = 0.010 + x$   
 Blue boundary  $y = 0.610 - x$   
 Green boundary  $y = 0.030 + x$   
 Yellow boundary  $y = 0.710 - x$   
 Luminance factor  $\beta = 0.75$  (mm)  
 (Day condition)  
 Relative luminance to white (night condition) 100%

(d)

Black  
 Purple boundary  $y = x - 0.030$   
 Blue boundary  $y = 0.570 - x$   
 Green boundary  $y = 0.050 + x$   
 Yellow boundary  $y = 0.740 - x$   
 Luminance factor  $\beta = 0.03$  (max)  
 (Day condition)  
 Relative luminance to white (night condition) 0% (min)  
 2% (max)

(e)

Green  
 Yellow boundary  $x = 0.313$   
 White boundary  $y = 0.243 + 0.670x$   
 Blue boundary  $y = 0.493 - 0.524x$   
 Luminance factor  $\beta = 0.10$  minimum (day conditions)  
 Relative luminance to white (night conditions) 5% (minimum)  
 30% (maximum)

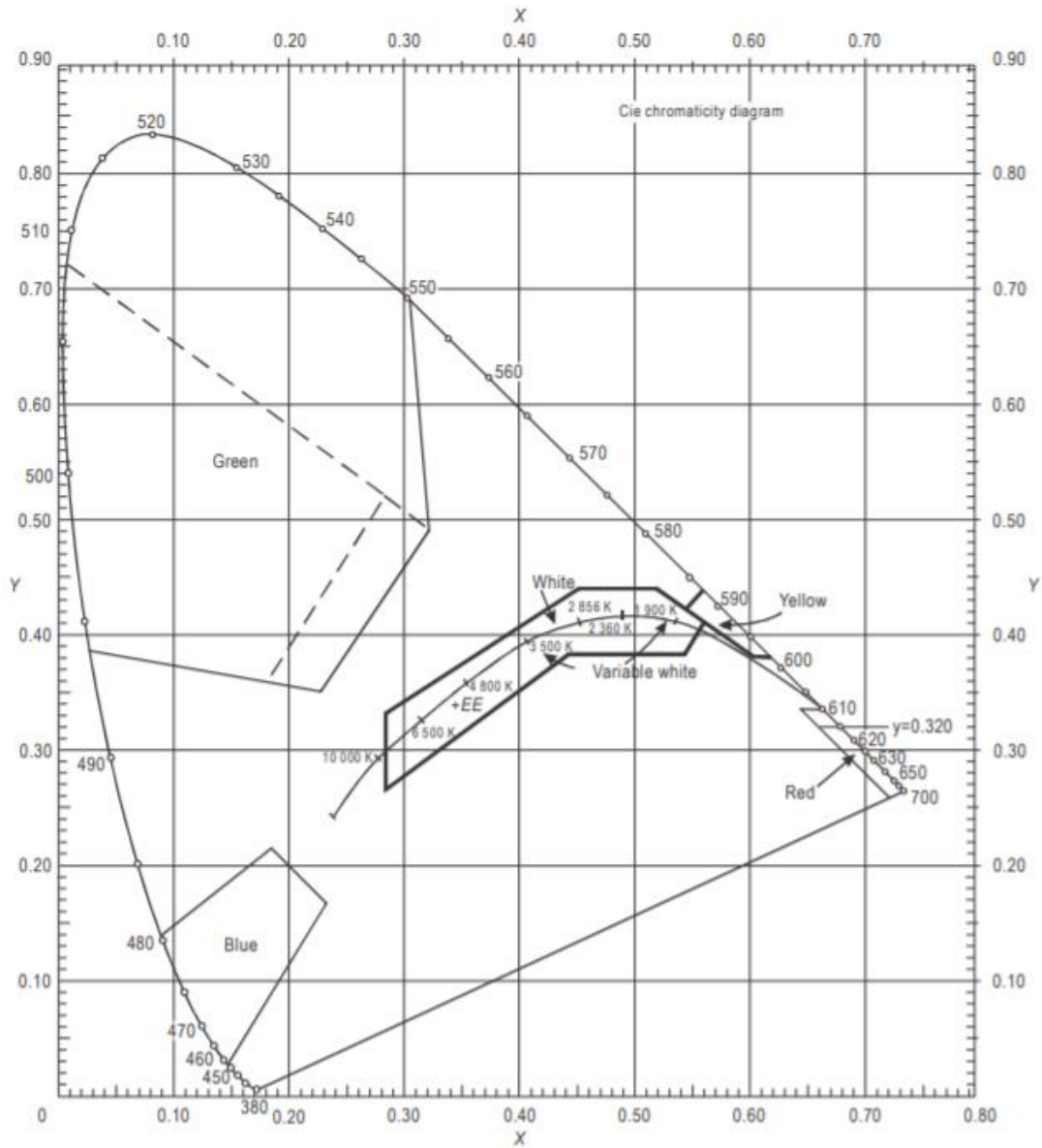

**Figure A1-1a. Colours for Aeronautical Ground Lights (Filament-Type Lamps)**

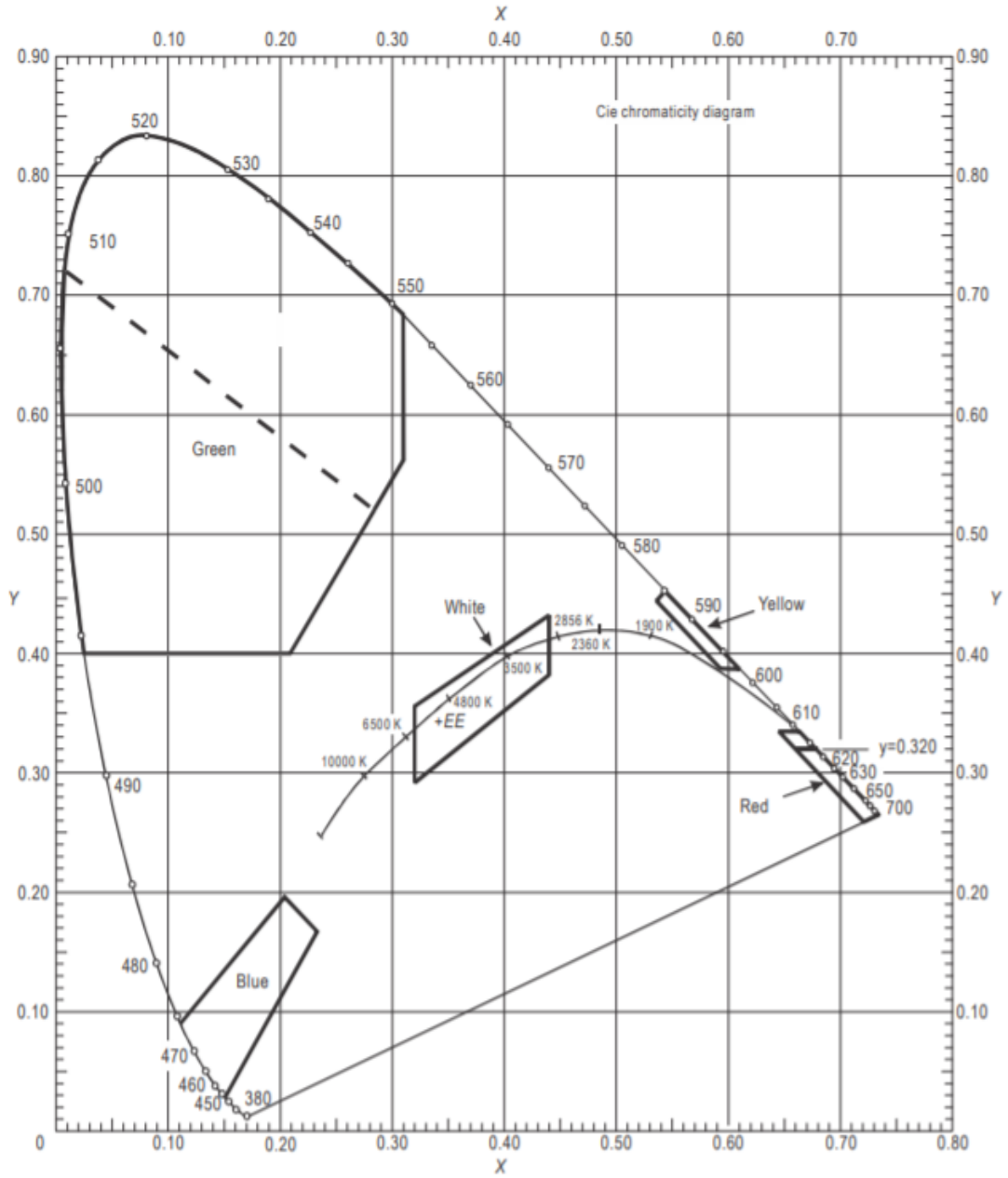

**Figure A1-1b. Colours for Aeronautical Ground Lights (Solid State Lighting)**

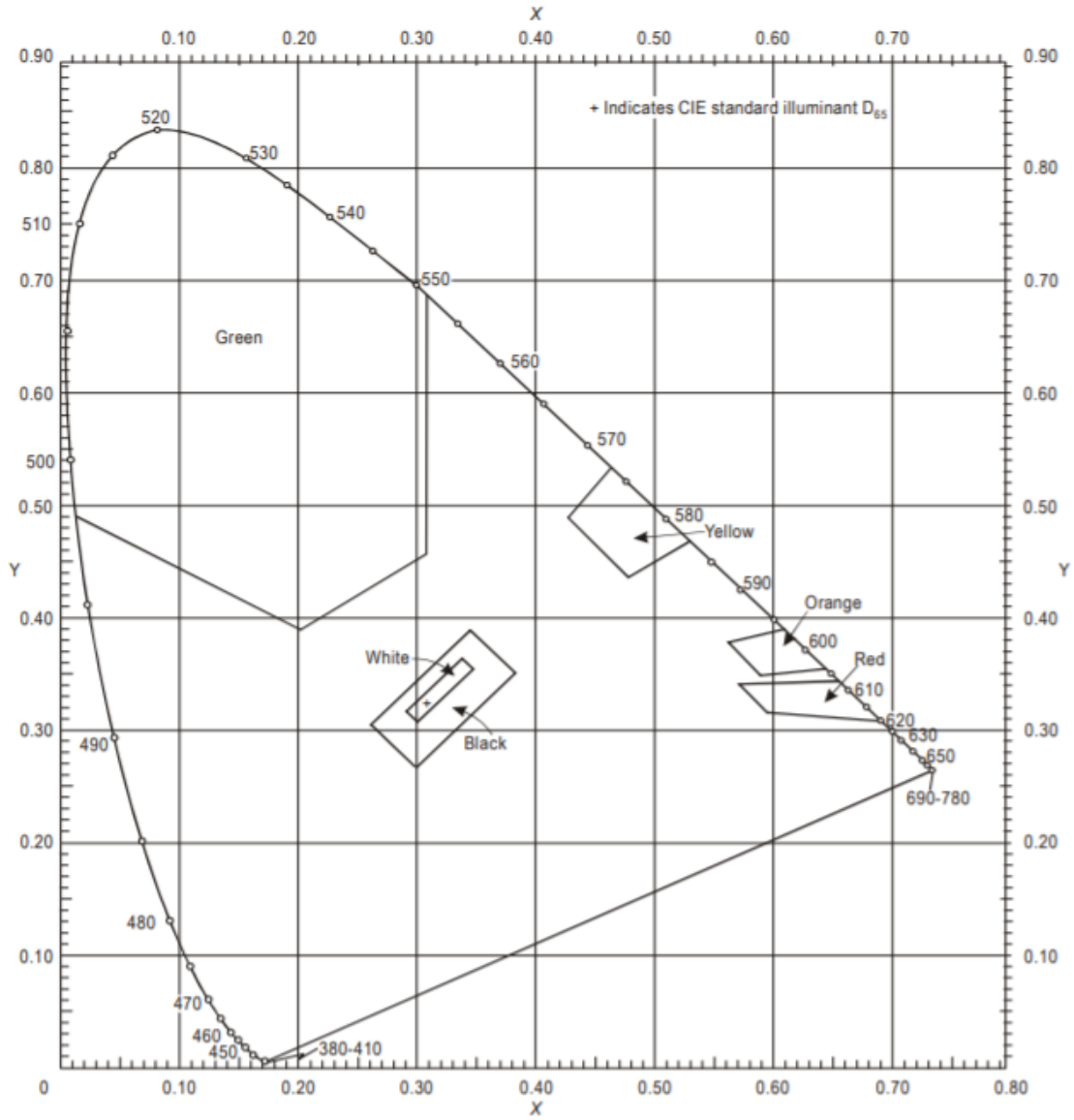

**Figure A1-2. Ordinary Colours for Markings and Externally Illuminated Signs and Panels**

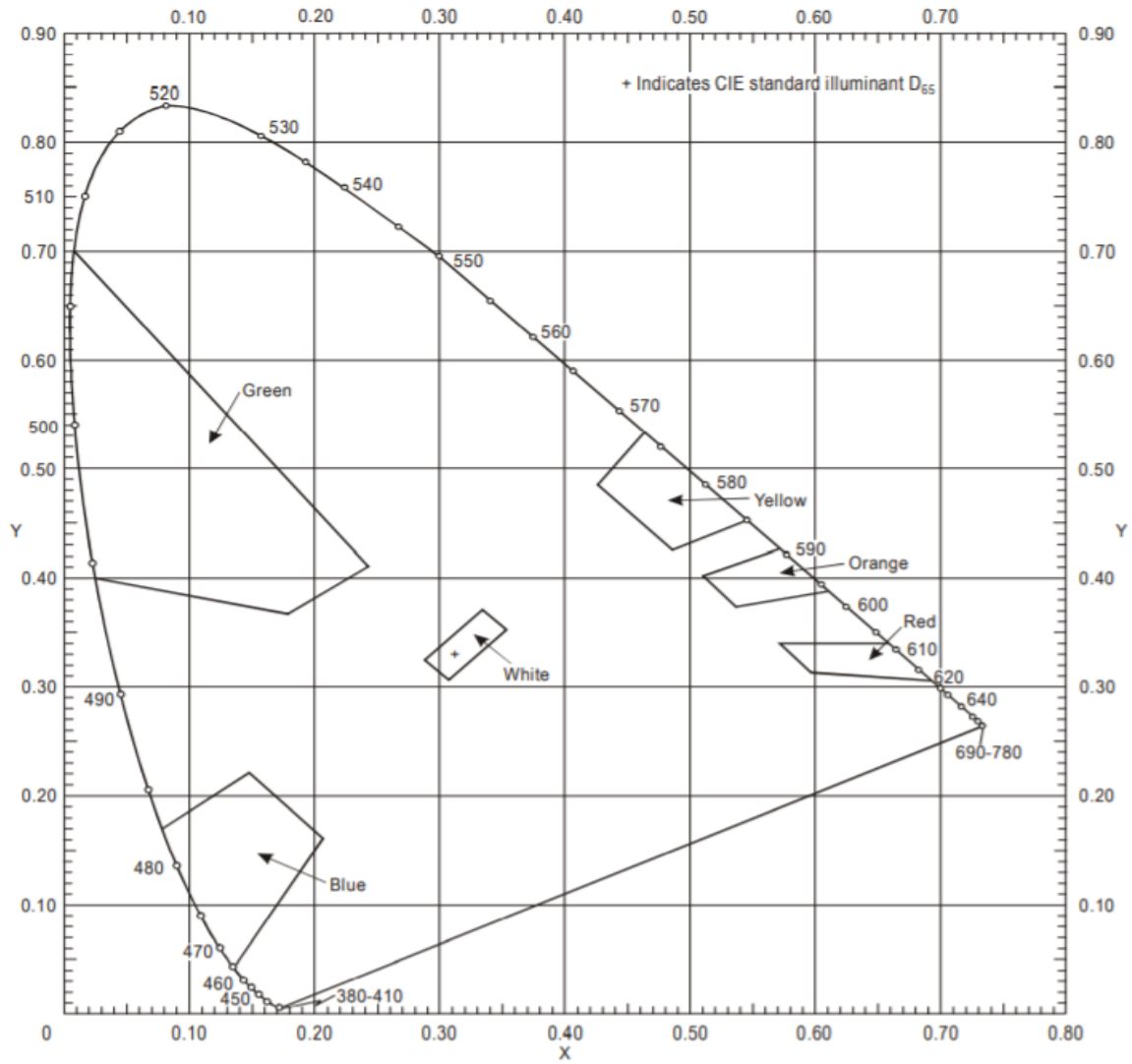

**Figure A1-3. Colours Of Retroreflective Materials for Markings, Signs and Panels**

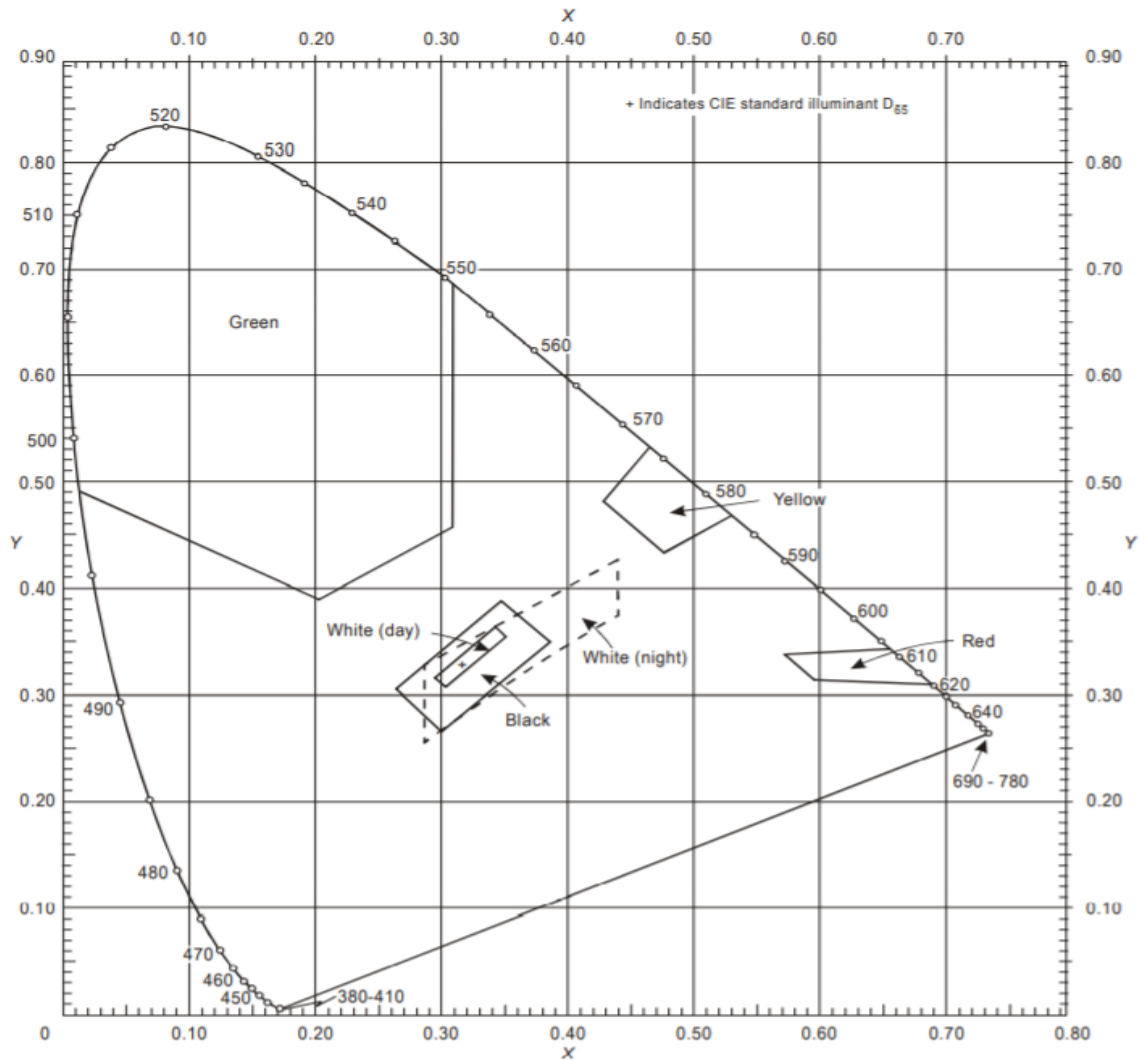
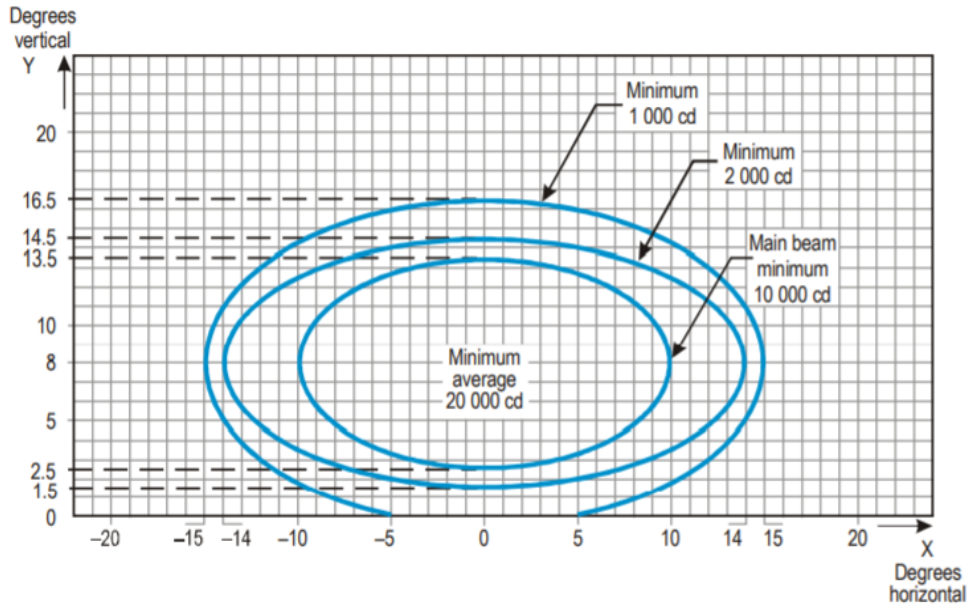

**Figure A1-4. Colours of Luminescent or Trans Illuminated (Internally Illuminated) Signs and Panels**

## FOURTH SCHEDULE

**Regulation 103, 110, 111, 114, 120, 121, 122, 123,  
124, 126, 128, 134, 135, 136, 137, 145, 146, 223**

### AERONAUTICAL GROUND LIGHT CHARACTERISTICS



Notes:

1. Curves calculated on formula  $\frac{x^2}{a^2} + \frac{y^2}{b^2} = 1$

a	10	14	15
b	5.5	6.5	8.5

2. Vertical setting angles of the lights shall be such that the following vertical coverage of the main beam shall be met:

distance from threshold	vertical main beam coverage
threshold to 315 m	0.0° — 11°
316 m to 475 m	0.5° — 11.5°
476 m to 640 m	1.5° — 12.5°
641 m and beyond	2.5° — 13.5° (as illustrated above)

3. Lights in crossbars beyond 22.5 m from the center line shall be toed-in 2 degrees. All other lights shall be aligned parallel to the center line of the runway
4. See collective notes for Figures A2-1 to A2-11 and A2-26.

**Figure A2-1. Isocandela Diagram for Approach Centre Line Light and Crossbars (White Light)**

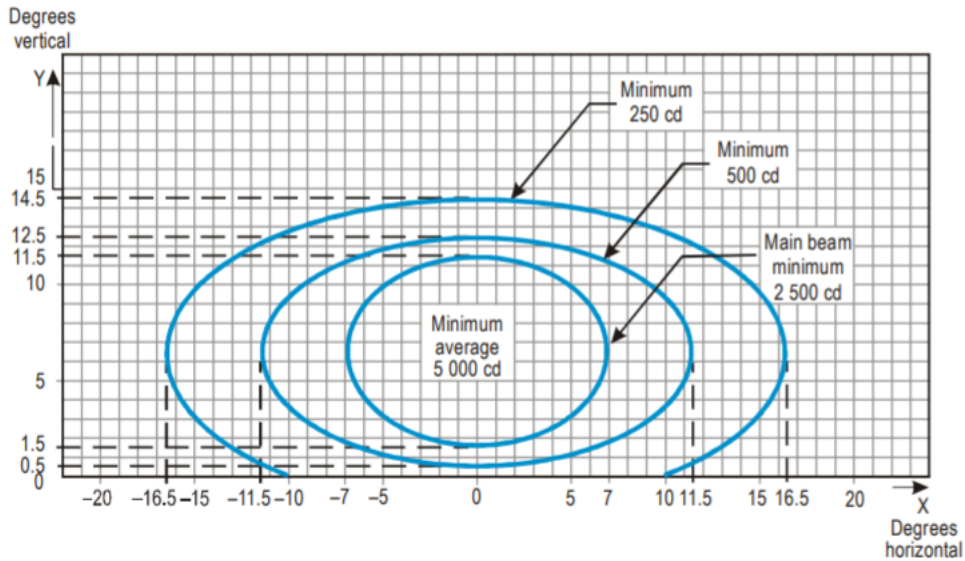

Notes:

1. Curves calculated on formula  $\frac{x^2}{a^2} + \frac{y^2}{b^2} = 1$

a	7	11.5	16.5
b	5.0	6.0	8.0

2. Toe-in 2 degrees.
3. Vertical setting angles of the lights shall be such that the following vertical coverage of the main beam will be met:

distance from threshold	vertical main beam coverage
threshold to 115 m	0.5° — 10.5°
116 m to 215 m	1° — 11°
216 m and beyond	1.5° — 11.5°

4. See collective notes for Figures A2-1 to A2-11 and A2-26.

**Figure A2-2. Isocandela Diagram for Approach Side Row Light (Red Light)**

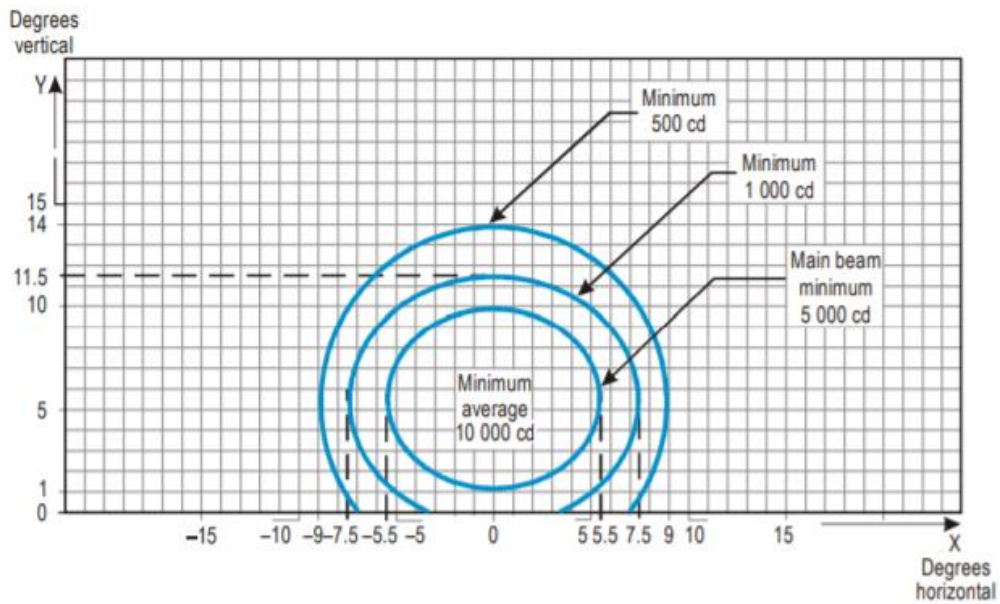

Notes:

1. Curves calculated on formula  $\frac{x^2}{a^2} + \frac{y^2}{b^2} = 1$

a	5.5	7.5	9.0
b	4.5	6.0	8.5

2. Toe-in 3.5 degrees.
3. See collective notes for Figures A2-1 to A2-11 and A2-26.

**Figure A2-3. Isocandela Diagram for Threshold Light (Green Light)**

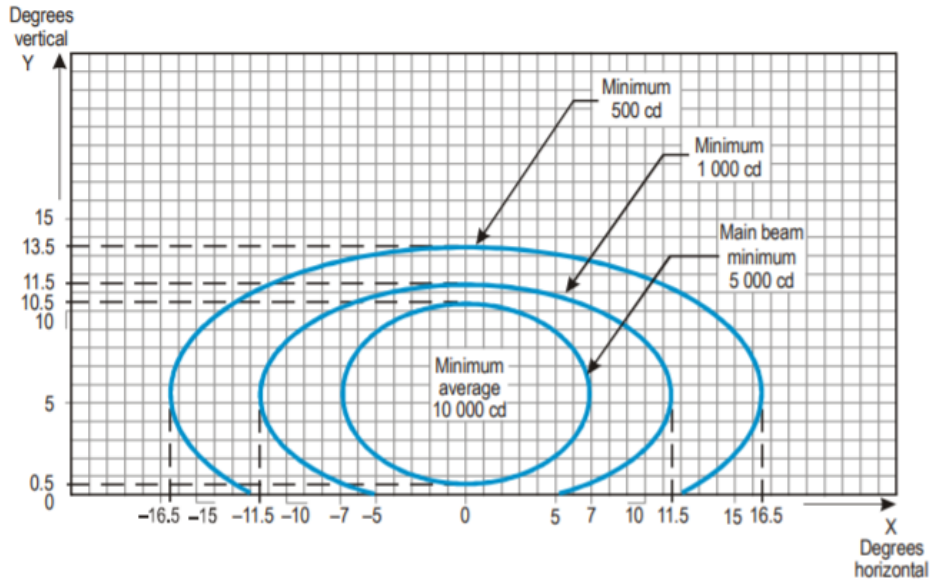

Notes:

1. Curves calculated on formula  $\frac{x^2}{a^2} + \frac{y^2}{b^2} = 1$

a	7.0	11.5	16.5
b	5.0	6.0	8.0

2. Toe-in 2 degrees.
3. See collective notes for Figures A2-1 to A2-11 and A2-26.

**Figure A2-4. Isocandela Diagram for Threshold Wing Bar Light (Green Light)**

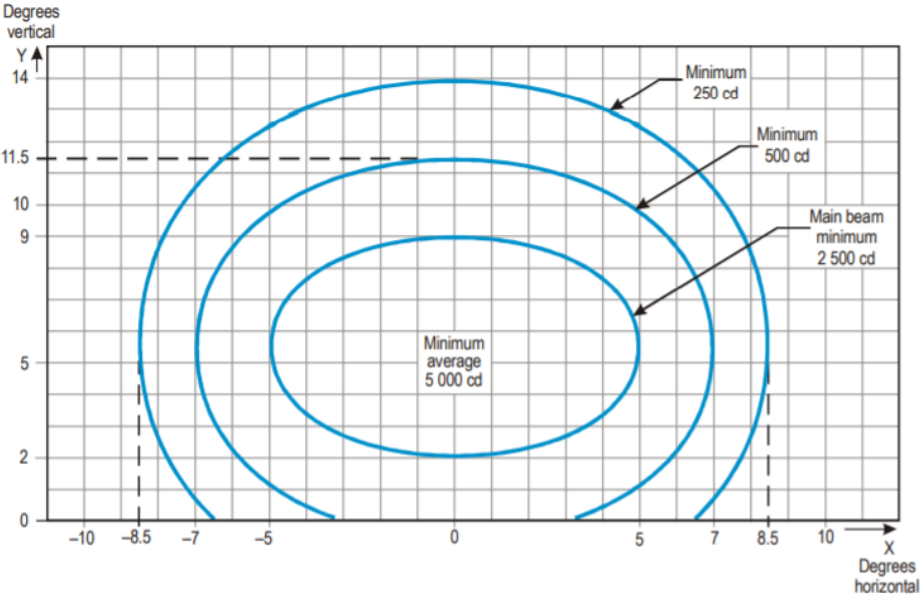

Notes:

1. Curves calculated on formula  $\frac{x^2}{a^2} + \frac{y^2}{b^2} = 1$

a	5.0	7.0	8.5
b	3.5	6.0	8.5

2. Toe-in 4 degrees.  
 3. See collective notes for Figures A2-1 to A2-11 and A2-26.

**Figure A2-5. Isocandela Diagram for Touchdown Zone Light (White Light)**

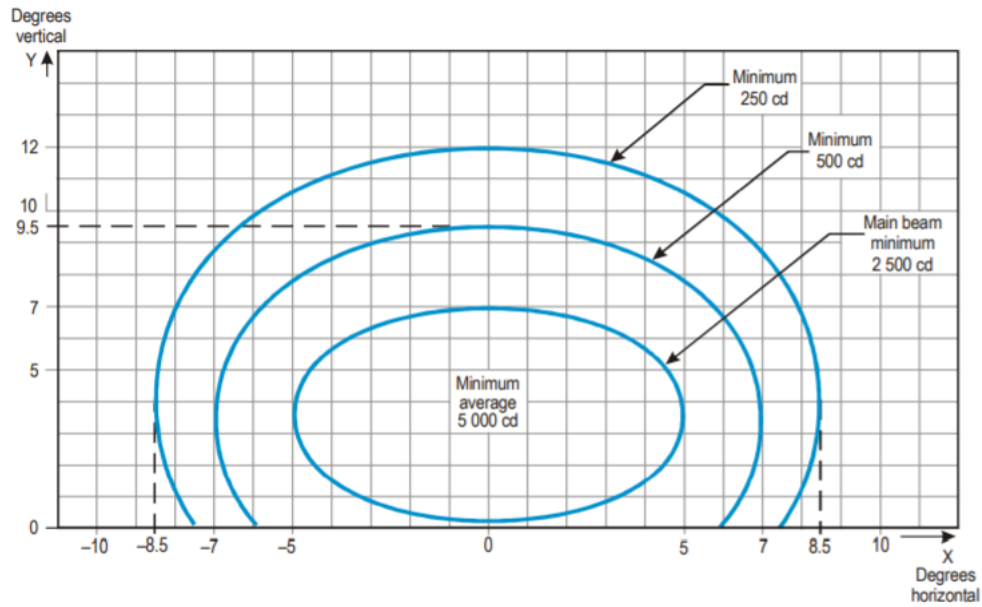

Notes:

1. Curves calculated on formula  $\frac{x^2}{a^2} + \frac{y^2}{b^2} = 1$

a	5.0	7.0	8.5
b	3.5	6.0	8.5

2. For red light, multiply values by 0.15.  
 3. For yellow light, multiply values by 0.40.  
 4. See collective notes for Figures A2-1 to A2-11 and A2-26.

**Figure A2-6. Isocandela Diagram for Runway Centre Line Light With 30 M Longitudinal Spacing (White Light) And Rapid Exit Taxiway Indicator Light (Yellow Light)**

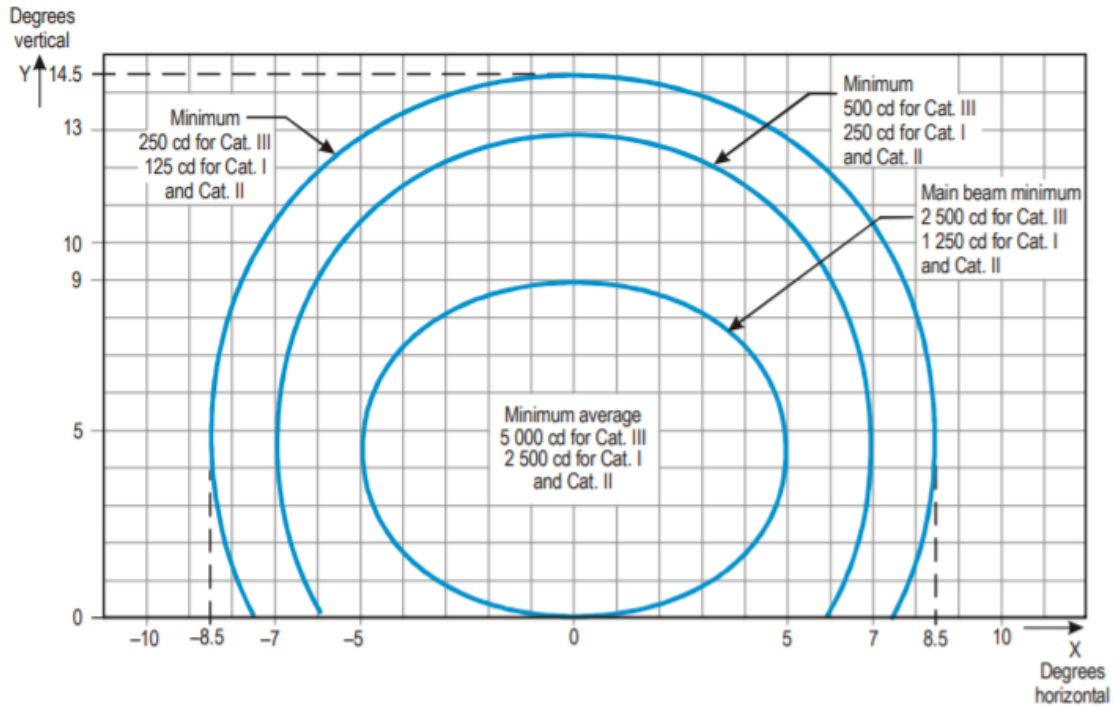

Notes:

1. Curves calculated on formula  $\frac{x^2}{a^2} + \frac{y^2}{b^2} = 1$

a	5.0	7.0	8.5
b	4.5	8.5	10

2. For red light, multiply values by 0.15.
3. For yellow light, multiply values by 0.40.
4. See collective notes for Figures A2-1 to A2-11 and A2-26.

**Figure A2-7. Isocandela Diagram for Runway Centre Line Light With 15 M Longitudinal Spacing (White Light) And Rapid Exit Taxiway Indicator Light (Yellow Light)**

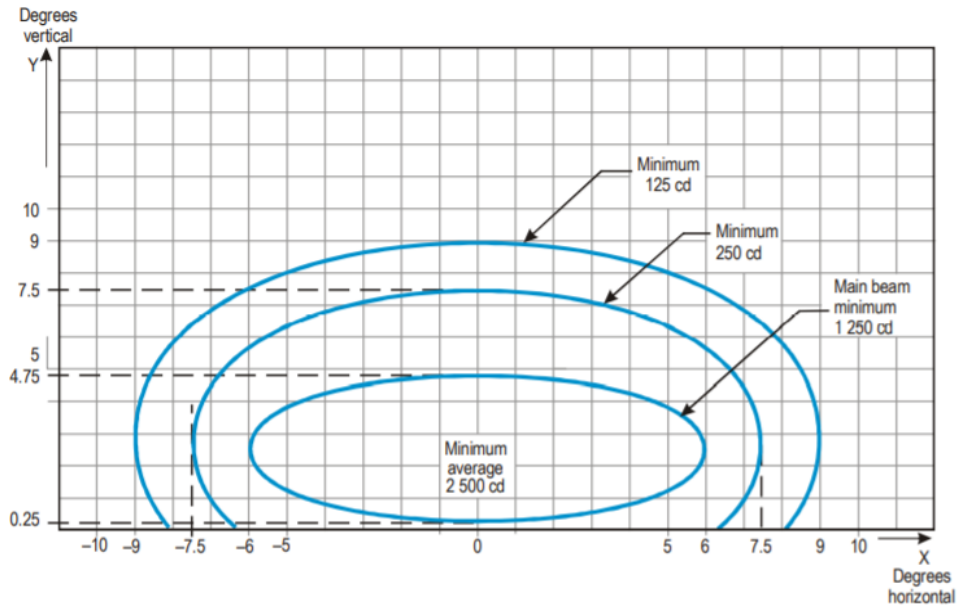

Notes:

- Curves calculated on formula  $\frac{x^2}{a^2} + \frac{y^2}{b^2} = 1$

a	6.0	7.5	9.0
b	2.25	5.0	6.5

- See collective notes for Figures A2-1 to A2-11 and A2-26.

**Figure A2-8. Isocandela Diagram for Runway End Light (Red Light)**

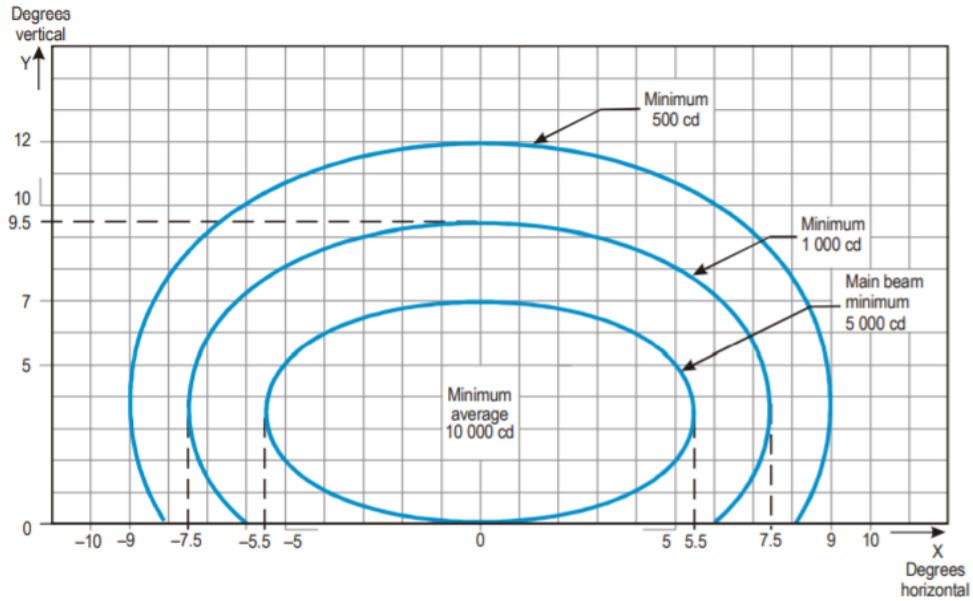

Notes:

1. Curves calculated on formula  $\frac{x^2}{a^2} + \frac{y^2}{b^2} = 1$

a	5.5	7.5	9.0
b	3.5	6.0	8.5

2. Toe-in 3.5 degrees
3. For red light, multiply values by 0.15.
4. For yellow light, multiply values by 0.40.
5. See collective notes for Figures A2-1 to A2-11 and A2-26.

**Figure A2-9. Isocandela Diagram for Runway Edge Light Where Width of Runway Is 45 M (White Light)**

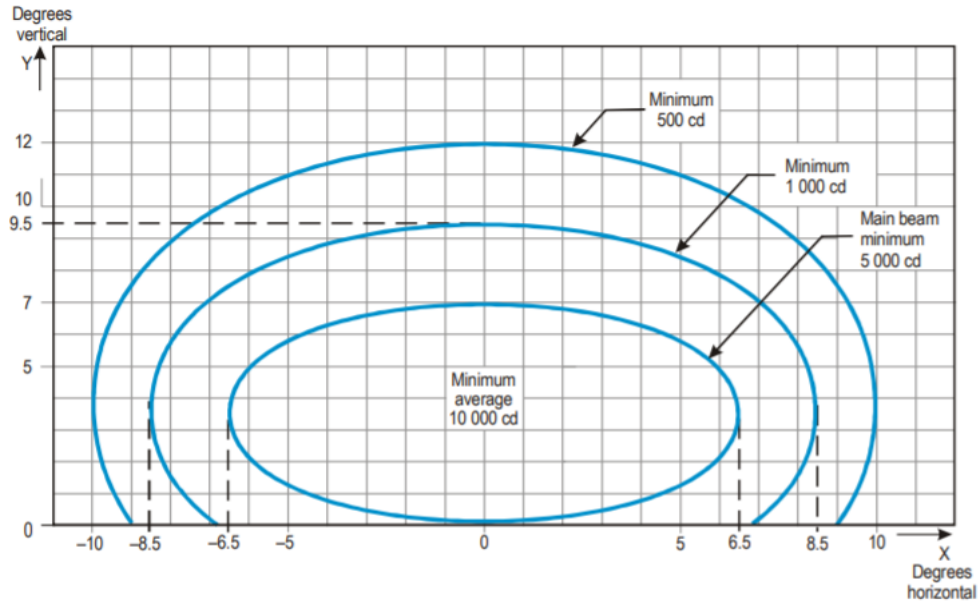

Notes:

- Curves calculated on formula  $\frac{x^2}{a^2} + \frac{y^2}{b^2} = 1$

a	6.5	8.5	10.0
b	3.5	6.0	8.5

- Toe-in 4.5 degrees
- For red light, multiply values by 0.15.
- For yellow light, multiply values by 0.40.
- See collective notes for Figures A2-1 to A2-11 and A2-26.

**Figure A2-10. Isocandela Diagram for Runway Edge Light Where Width of Runway Is 60 M (White Light)**

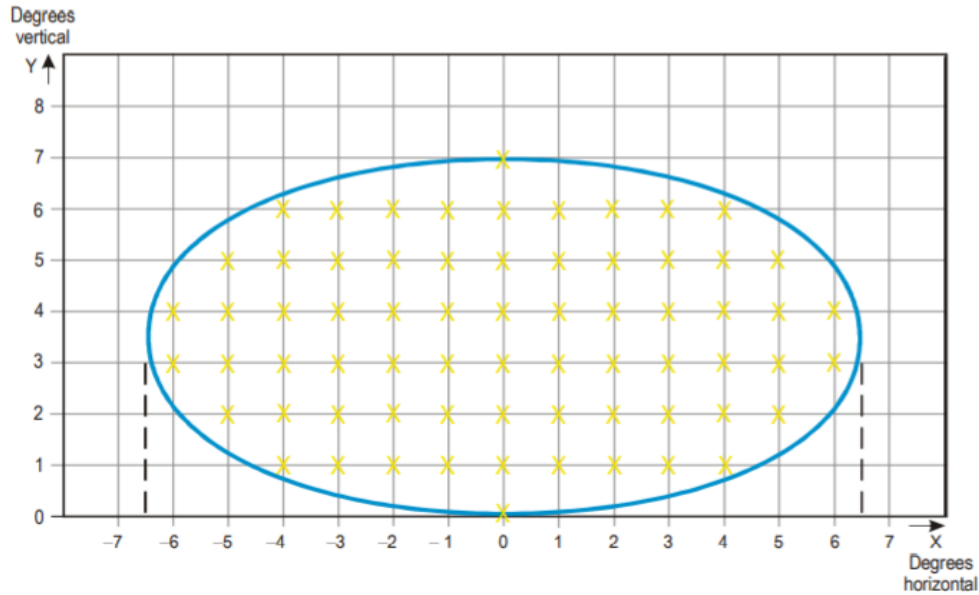

**Figure A2-11. Grid Points to Be Used for The Calculation of Average Intensity of Approach and Runway Lights**

Collective notes to Figures A2-1 to A2-11

1. The ellipses in each figure are symmetrical about the common vertical and horizontal axes.
2. Figures A2-1 to A2-10 show the minimum allowable light intensities. The average intensity of the main beam is calculated by establishing grid points as shown in Figure A2-11 and using the intensity value measures at all grid points located within and on the perimeter of the ellipse representing the main beam. The average value is the arithmetic average of light intensities measured at all considered grid points.
3. No deviations are acceptable in the main beam pattern when the lighting fixture is properly aimed.
4. Average intensity ratio. The ratio between the average intensity within the ellipse defining the main beam of a typical new light and the average light intensity of the main beam of a new runway edge light shall be as follows:

Figure A2-1	Approach centre line and crossbars	1.5 to 2.0 (white light)
Figure A2-2	Approach side row	0.5 to 1.0 (red light)
Figure A2-3	Threshold	1.0 to 1.5 (green light)
Figure A2-4	Threshold wing bar	1.0 to 1.5 (green light)

Figure A2-5	Touchdown zone	0.5 to 1.0 (white light)
Figure A2-6	Runway centre line (longitudinal spacing 30 m)	0.5 to 1.0 (white light)
Figure A2-7	Runway centre line (longitudinal spacing 15 m)	0.5 to 1.0 for CAT III (white light) 0.25 to 0.5 for CAT I, II (white light)
Figure A2-8	Runway end	0.25 to 0.5 (red light)
Figure A2-9	Runway edge (45 m runway width)	1.0 (white light)
Figure A2-10	Runway edge (60 m runway width)	1.0 (white light)

5. The beam coverages in the figures provide the necessary guidance for approaches down to an RVR of the order of 150 m and take-offs down to an RVR of the order of 100 m.
6. Horizontal angles are measured with respect to the vertical plane through the runway centre line. For lights other than centre line lights, the direction towards the runway centre line is considered positive. Vertical angles are measured with respect to the horizontal plane.
7. Where, for approach centre line lights and crossbars and for approach side row lights, inset lights are used in lieu of elevated lights, e.g. on a runway with a displaced threshold, the intensity requirements can be met by installing two or three fittings (lower intensity) at each position.
8. The importance of adequate maintenance cannot be overemphasized. The average intensity shall never fall to a value less than 50 per cent of the value shown in the figures, and it shall be the aim of airport authorities to maintain a level of light output close to the specified minimum average intensity.
9. The light unit shall be installed so that the main beam is aligned within one-half degree of the specified requirement.

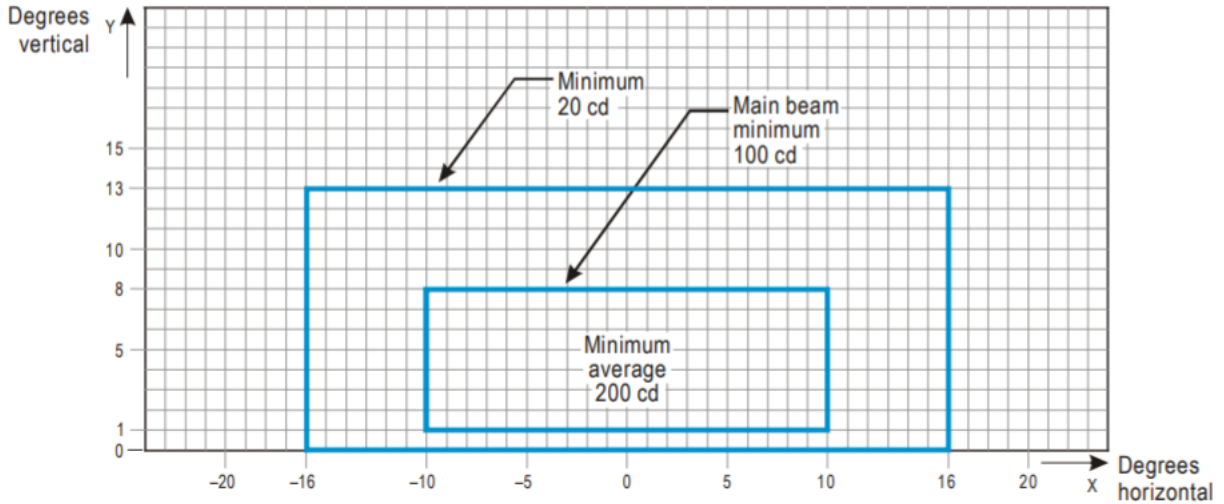

Notes:

1. These beam coverages allow for displacement of the cockpit from the centre line up to distances of the order of 12 m and are intended for use before and after curves.
2. See collective notes for Figures A2-12 to A2-21.
3. Increased intensities for enhanced rapid exit taxiway centre line lights as recommended in 5.3.16.9 are four times the respective intensities in the figure (i.e. 800 cd for minimum average main beam).

**Figure A2-12. Isocandela Diagram for Taxiway Center Line (15 M Spacing), No-Entry Bar and Stop Bar Lights in Straight Sections Intended for Use in Runway Visual Range Conditions of Less Than a Value Of 350 M Where Large Offsets Can Occur and For Low-Intensity Runway Guard Lights, Configuration B**

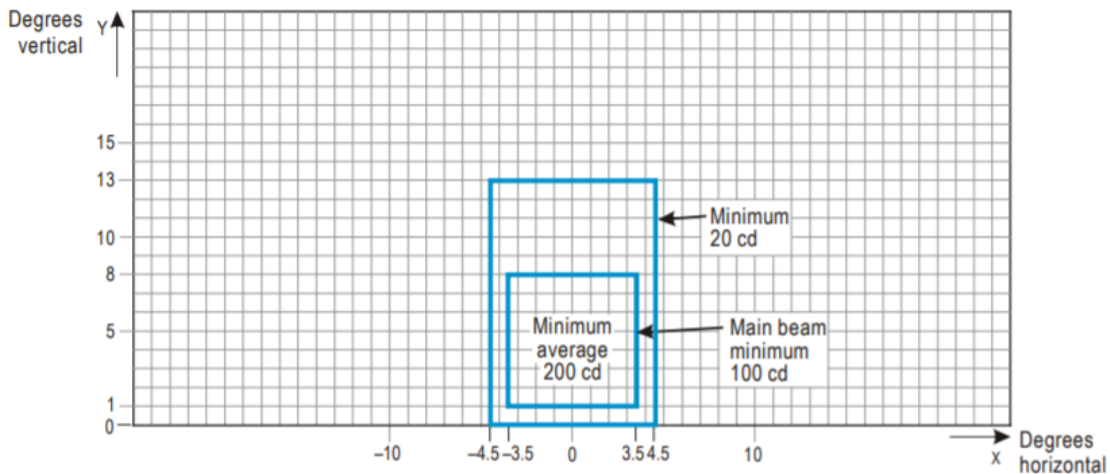

Notes:

1. These beam coverages are generally satisfactory and cater for a normal displacement of the cockpit from the center line of approximately 3 m.
2. See collective notes for Figures A2-12 to A2-21.

**Figure A2-13. Isocandela Diagram for Taxiway Center Line (15 M Spacing), No-Entry Bar and Stop Bar Lights in Straight Sections Intended for Use in Runway Visual Range Conditions of Less Than a Value Of 350 M**

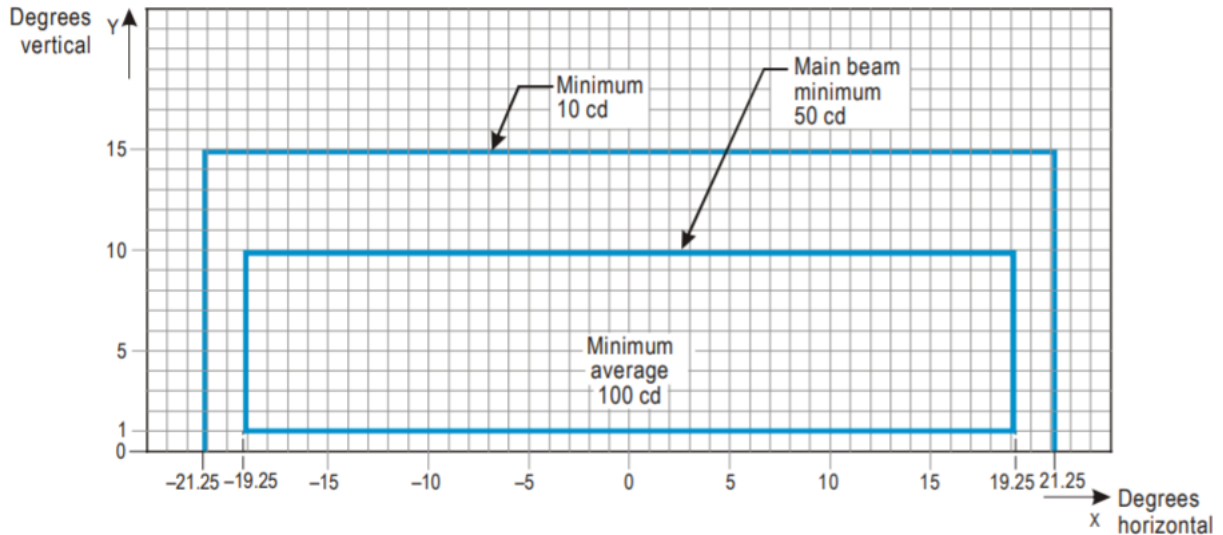

Notes:

1. Lights on curves to be toed-in 15.75 degrees with respect to the tangent of the curve. This does not apply to runway entrance lights (RELs)
2. Increased intensities for RELs shall be twice the specified intensities, i.e., minimum 20 cd, main beam minimum 100 cd and minimum average 200 cd.
3. See collective notes for Figures A2-12 to A2-21.

**Figure A2-14. Isocandela Diagram for Taxiway Center Line (7.5 M Spacing), Rels, No-Entry Bar and Stop Bar Lights in Curved Sections Intended for Use in Runway Visual Range Conditions of Less Than a Value Of 350 M**

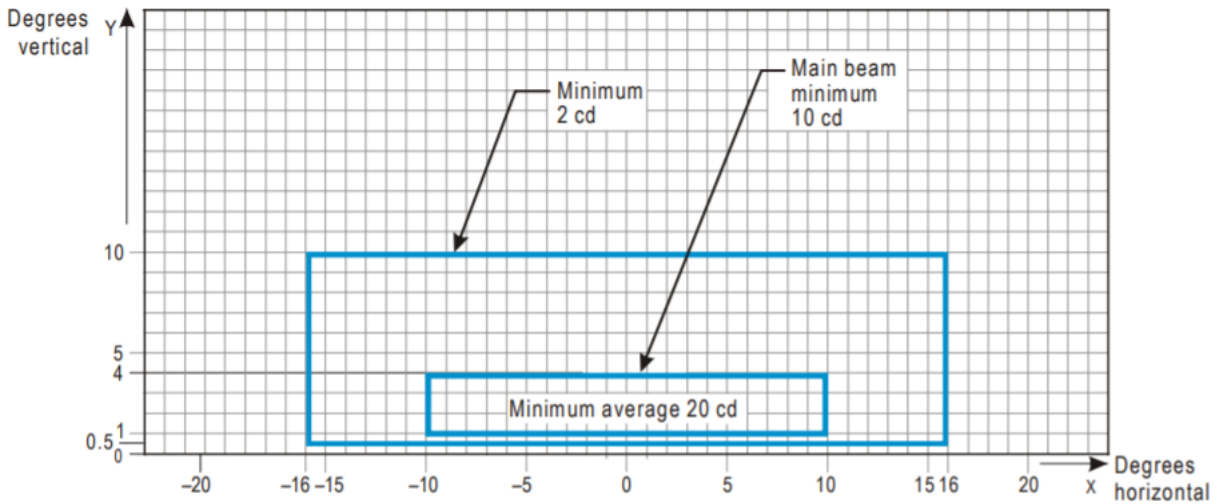

Notes:

1. At locations where high background luminance is usual and where deterioration of light output resulting from dust, snow and local contamination is a significant factor, the cd-values should be multiplied by 2.5.
2. Where omnidirectional lights are used, they shall comply with the vertical beam requirements in this figure.
3. See collective notes for Figures A2-12 to A2-21

**Figure A2-15. Isocandela Diagram for Taxiway Center Line (30 M, 60 M Spacing), No-Entry Bar and Stop Bar Lights in Straight Sections Intended for Use in Runway Visual Range Conditions Of 350 M or Greater**

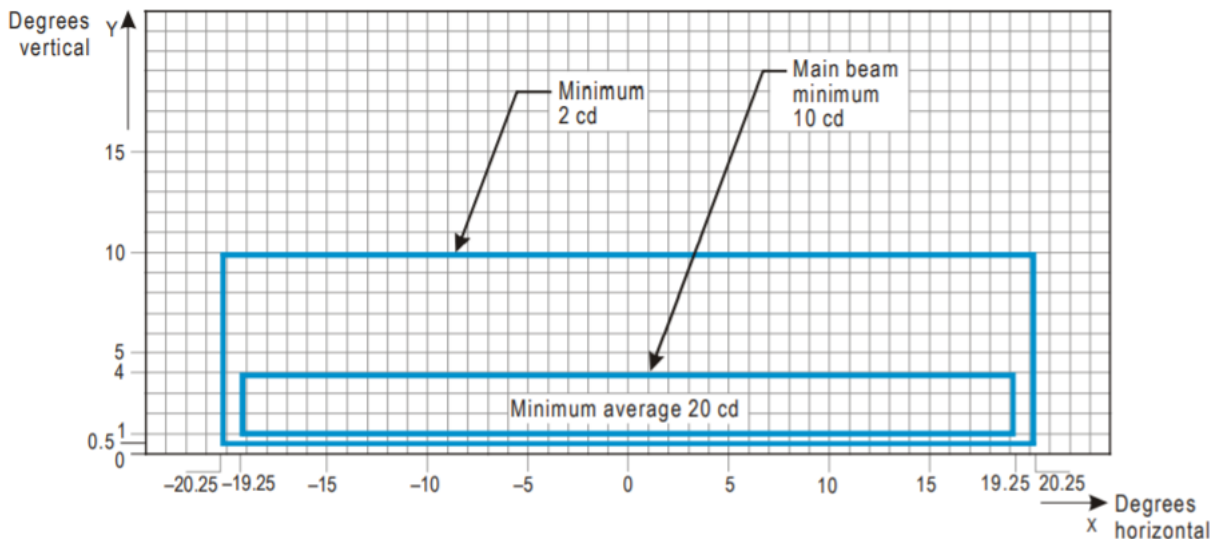

Notes:

1. Lights on curves to be toed-in 15.75 degrees with respect to the tangent of the curve.
2. At locations where high background luminance is usual and where deterioration of light output resulting from dust, snow and local contamination is a significant factor, the cd-values should be multiplied by 2.5.
3. These beam coverages allow for displacement of the cockpit from the centre line up to distances of the order of 12 m as could occur at the end of curves.
4. See collective notes for Figures A2-12 to A2-21.

**Figure A2-16. Isocandela Diagram for Taxiway Centre Line (7.5 M, 15 M, 30 M Spacing), No-Entry Bar and Stop Bar Lights in Curved Sections Intended for Use in Runway Visual Range Conditions Of 350 M or Greater**

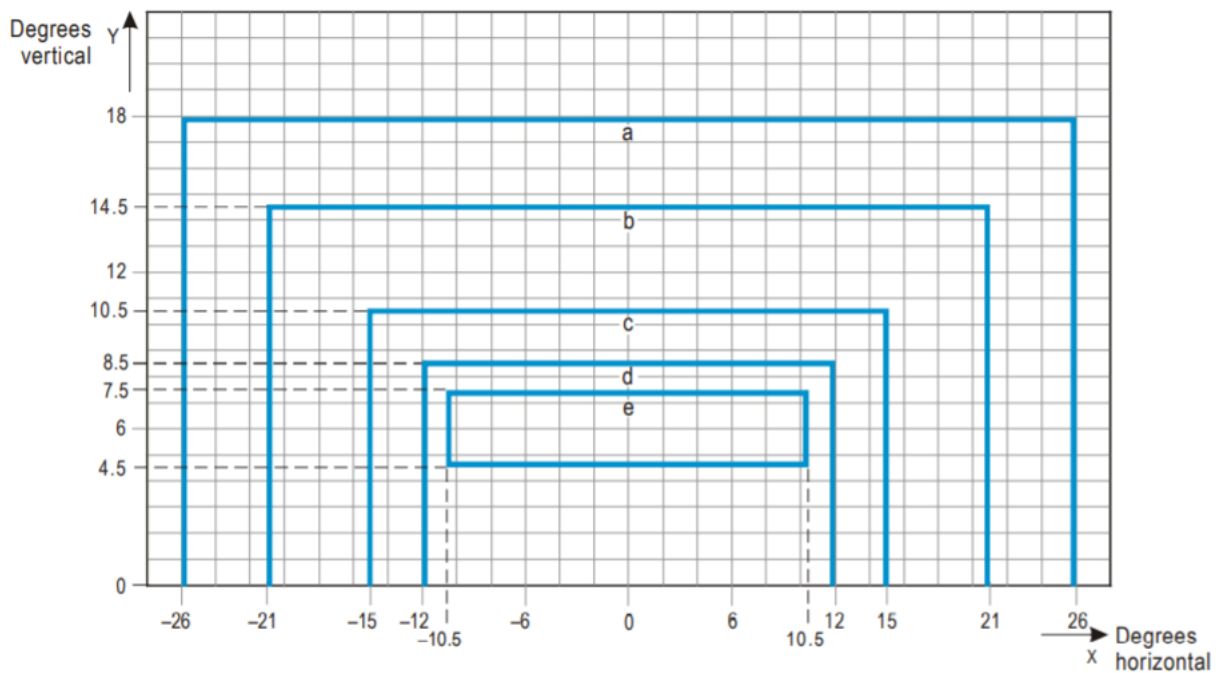

Curve	a	b	c	d	e
Intensity (cd)	8	20	100	450	1800

Notes:

1. These beam coverages allow for displacement of the cockpit from the Centre line up to distances of the order of 12 m and are intended for use before and after curves.
2. See collective notes for Figures A2-12 to A2-21.

**Figure A2-17. Isocandela Diagram for High-Intensity Taxiway Center Line (15 M Spacing), No-Entry Bar and Stop Bar Lights in Straight Sections Intended for Use in An Advanced Surface Movement Guidance and Control System Where Higher Light Intensities Are Required and Where Large Offsets Can Occur**

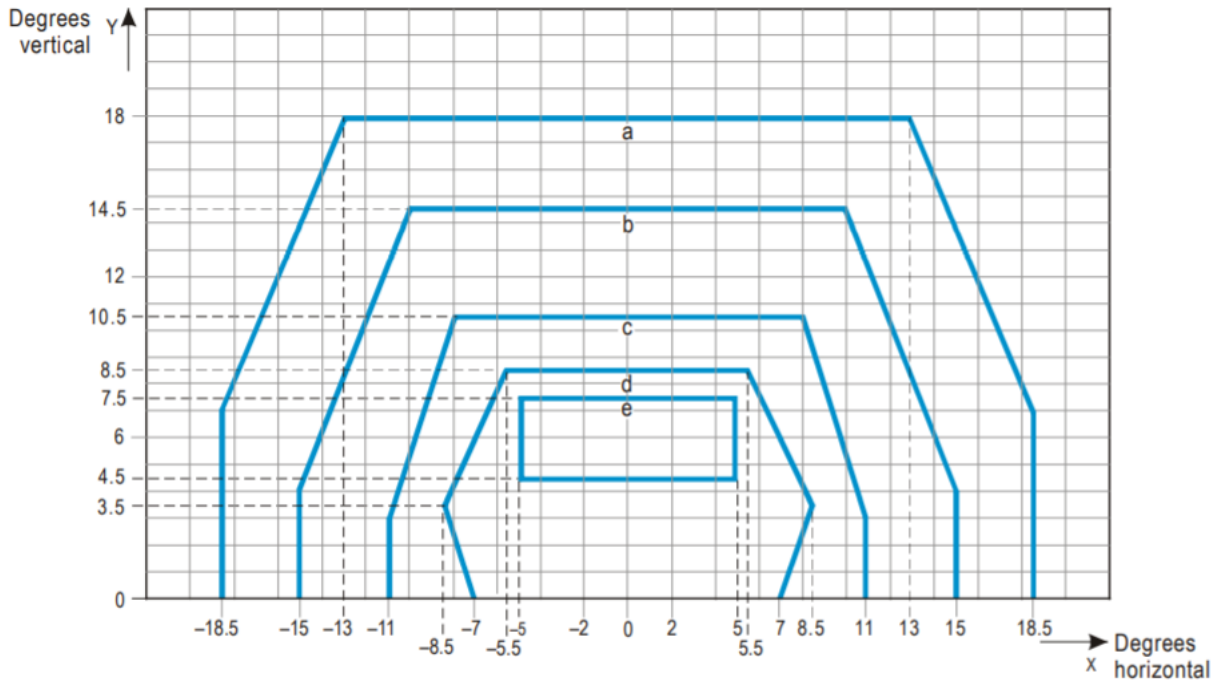

Curve	a	b	c	d	e
Intensity (cd)	8	20	100	450	1800

Notes:

1. These beam coverages are generally satisfactory and cater for a normal displacement of the cockpit corresponding to the outer main gear wheel on the taxiway edge.
2. See collective notes for Figures A2-12 to A2-21.

**Figure A2-18. Isocandela Diagram for High-Intensity Taxiway Centre Line (15 M Spacing), No-Entry Bar and Stop Bar Lights in Straight Sections Intended for Use in An Advanced Surface Movement Guidance and Control System Where Higher Light Intensities Are Required**

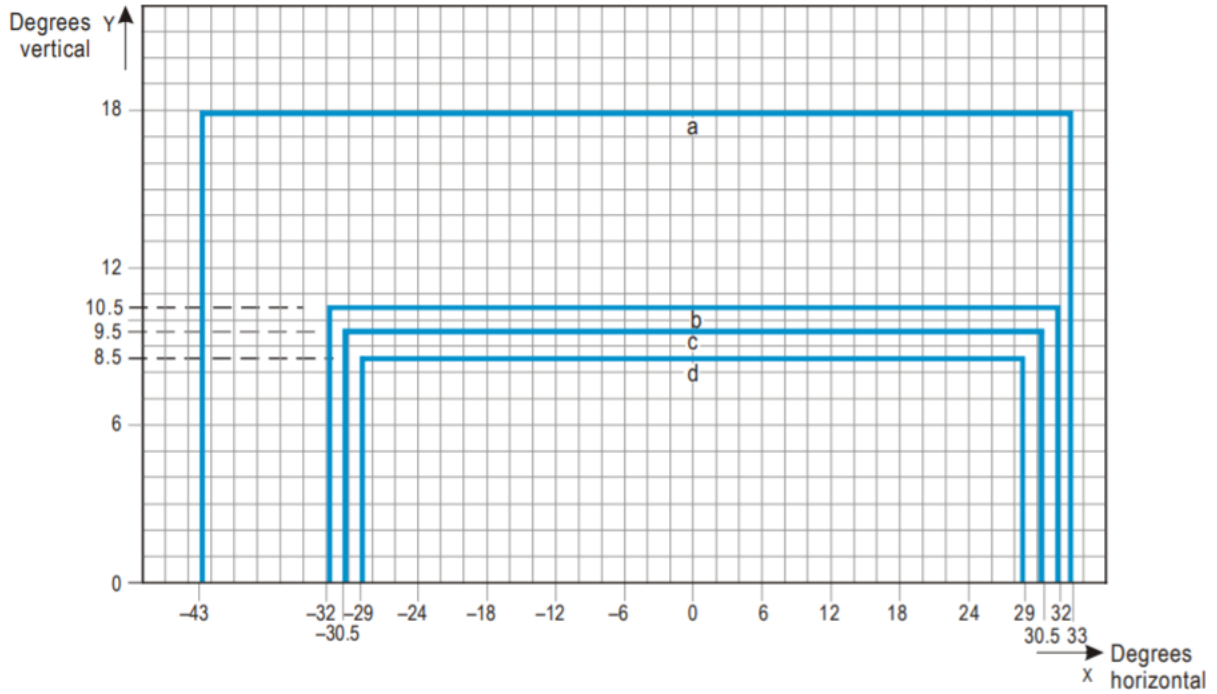

Curve	a	b	c	d
Intensity (cd)	8	100	200	400

Notes:

1. Lights on curves to be toed-in 17 degrees with respect to the tangent of the curve.
2. See collective notes for Figures A2-12 to A2-21.

**Figure A2-19. Isocandela Diagram for High-Intensity Taxiway Centre Line (7.5 M Spacing), No-Entry Bar and Stop Bar Lights in Curved Sections Intended for Use in An Advanced Surface Movement Guidance and Control System Where Higher Light Intensities Are Required.**

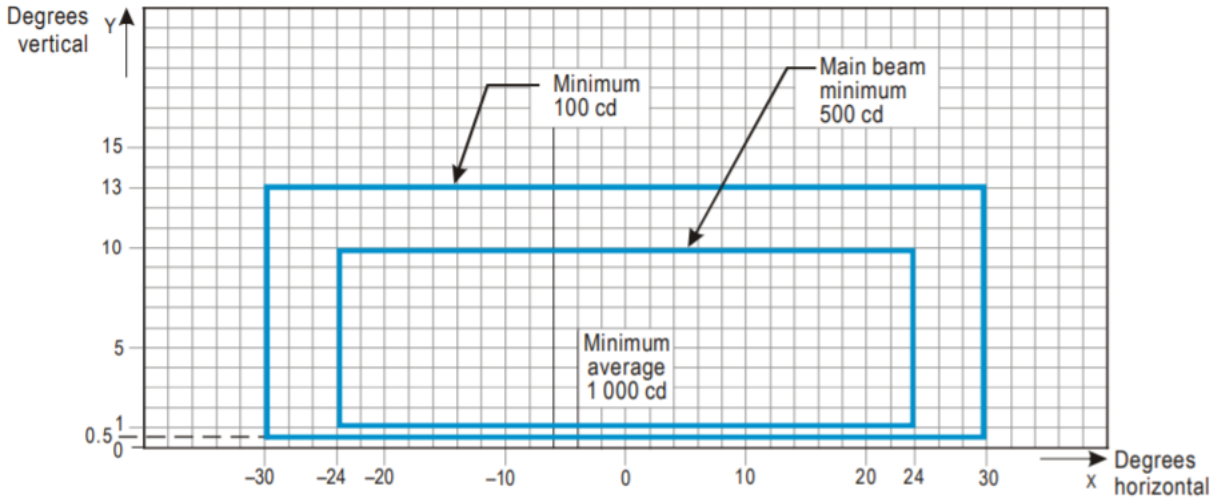

Notes:

1. Although the lights flash in normal operation, the light intensity is specified as where the lights were fixed for incandescent lamps.
2. See collective notes for Figures A2-12 to A2-21.

**Figure A2-20. Isocandela Diagram for High-Intensity Runway Guard Lights, Configuration B**

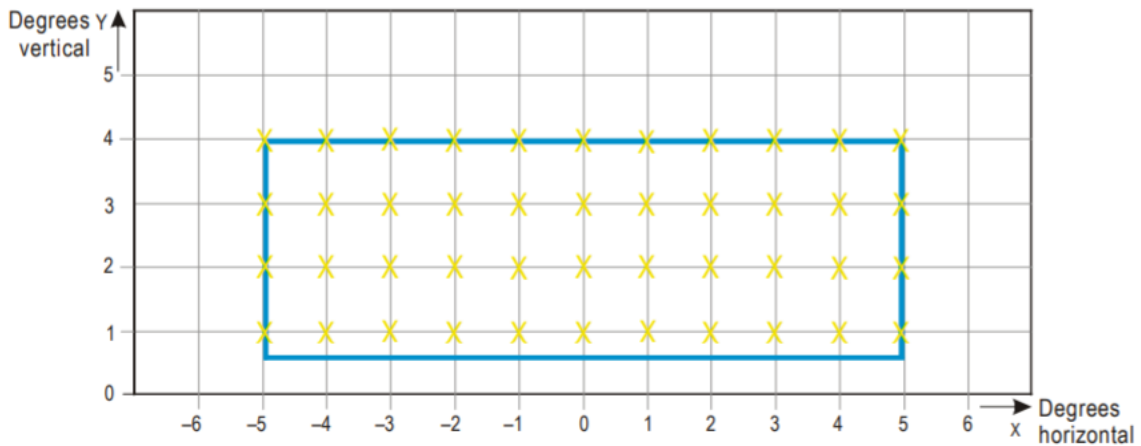

**Figure A2-21. Grid Points to Be Used for Calculation of Average Intensity of Taxiway Centre Line and Stop Bar Lights**

## Collective notes to Figures A2-12 to A2-21

1. The intensities specified in Figures A2-12 to A2-20 are in green and yellow light for taxiway center line lights, yellow light for runway guard lights and red light for stop bar lights.
2. Figures A2-12 to A2-20 show the minimum allowable light intensities. The average intensity of the main beam is calculated by establishing grid points as shown in Figure A2-21 and using the intensity values measured at all grid points located within and on the perimeter of the rectangle representing the main beam. The average value is the arithmetic average of the light intensities measured at all considered grid points.
3. No deviations are acceptable in the main beam or in the innermost beam, as applicable, when the lighting fixture is properly aimed.
4. Horizontal angles are measured with respect to the vertical plane through the taxiway centre line except on curves where they are measured with respect to the tangent to the curve.
5. Vertical angles are measured from the longitudinal slope of the taxiway surface.
6. The importance of adequate maintenance cannot be overemphasized. The intensity, either average where applicable or as specified on the corresponding iso candela curves, shall never fall to a value less than 50 per cent of the value shown in the figures, and it shall be the aim of airport authorities to maintain a level of light output close to the specified minimum average intensity.
7. The light unit shall be installed so that the main beam or the innermost beam, as applicable, is aligned within one-half degree of the specified requirement.

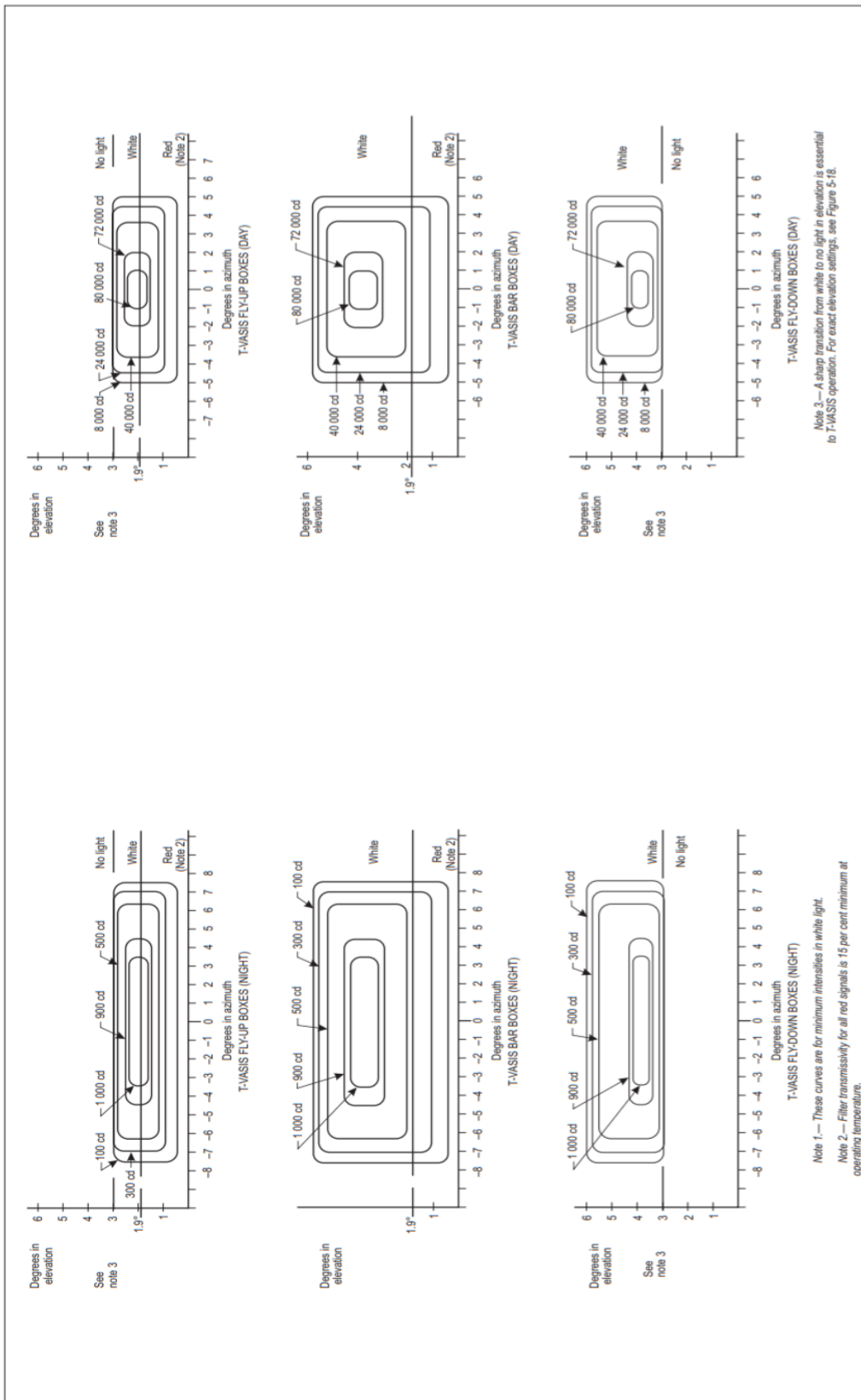

**Figure A2-22. Light intensity distribution of T-VASIS and AT-VASIS**

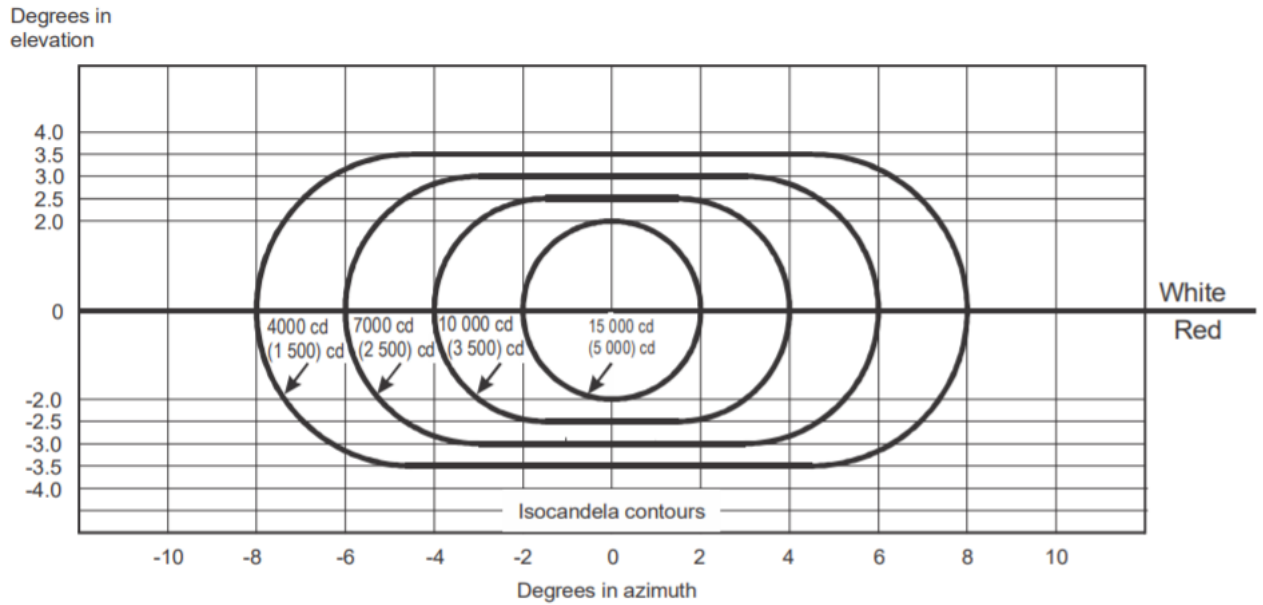

Notes:

1. These curves are for minimum intensities in red light.
2. The intensity value in the white sector of the beam is no less than 2 and may be as high as 6.5 times the corresponding intensity in the red sector.
3. The intensity values shown in brackets are for APAPI.

**Figure A2-23. Light Intensity Distribution of PAPI and APAPI**

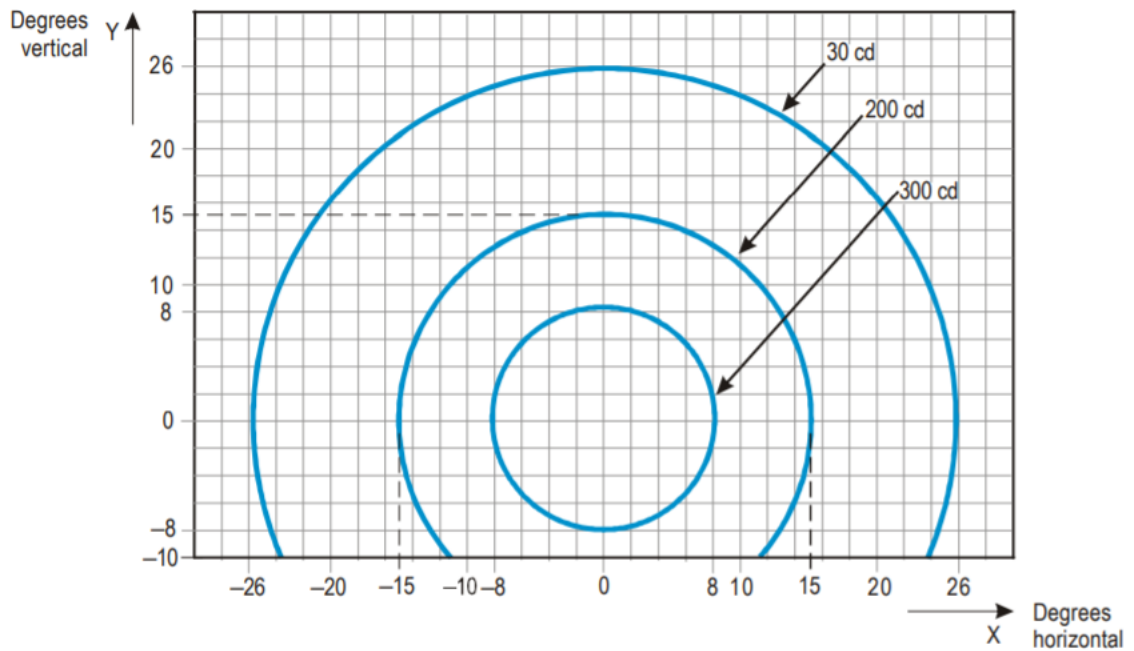

Notes:

1. Although the lights flash in normal operation, the light intensity is specified as where the lights were fixed for incandescent lamps.
2. The intensities specified are in yellow light.

**Figure A2-24. Isocandela Diagram for Each Light in Low-Intensity Runway Guard Lights, Configuration A**

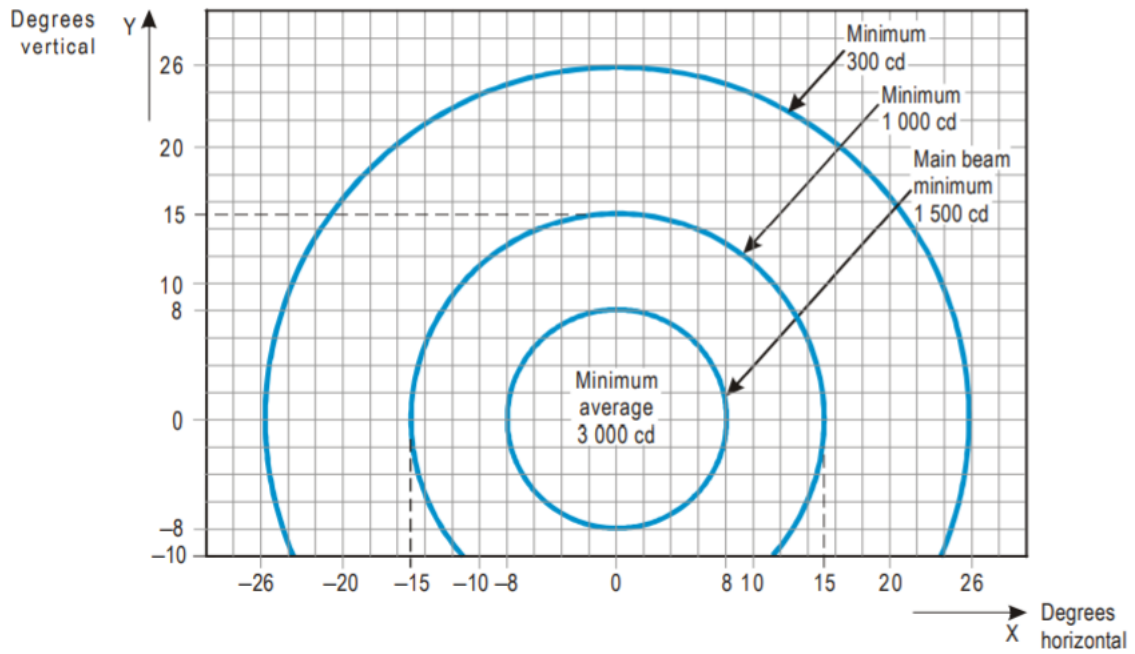

Notes:

1. Although the lights flash in normal operation, the light intensity is specified as where the lights were fixed for incandescent lamps.
2. The intensities specified are in yellow light.

**Figure A2-25. Isocandela Diagram for Each Light in High-Intensity Runway Guard Lights, Configuration A**

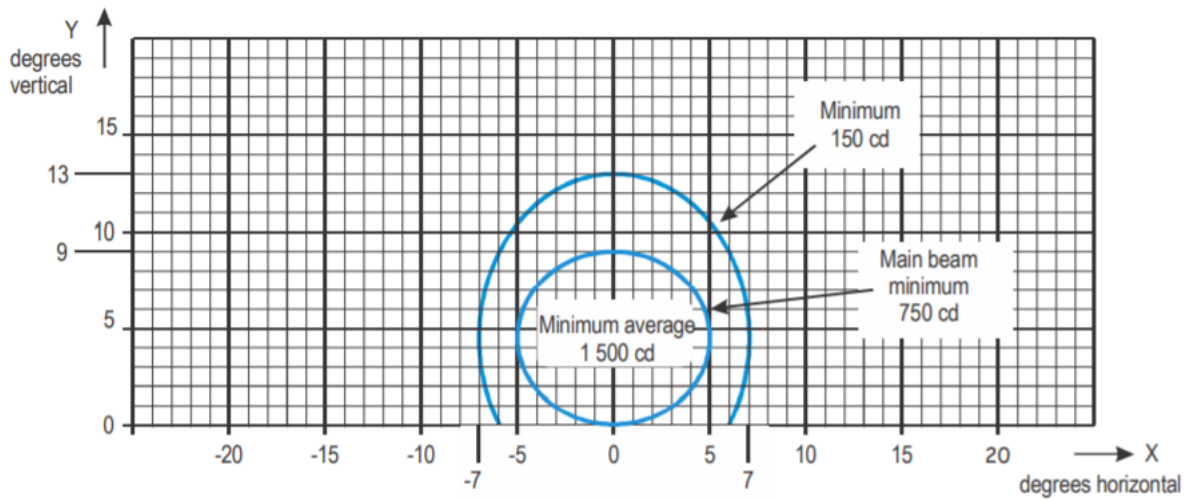

Notes:

1. Curves calculated on formula  $\frac{x^2}{a^2} + \frac{y^2}{b^2} = 1$

a	5.0	7.0
b	4.5	8.5

2. Toe-in 4.5 degrees
3. See collective notes for Figures A2-1 to A2-11 and A2-26.

**Figure A2-26. Isocandela Diagram for Take-Off and Hold Lights (THL) (Red Light)**

## FIFTH SCHEDULE

### Regulation

#### MANDATORY INSTRUCTION MARKINGS AND INFORMATION MARKINGS

- Note 1: See Part XII, Regulation and, for specifications on the application, location and characteristics of mandatory instruction markings and information markings.
- Note 2: This schedule details the form and proportions of the letters, numbers and symbols of mandatory instruction markings and information markings on a grid.
- Note 3: The mandatory instruction markings and information markings on pavements are formed as where shadowed (i.e., stretched) from the characters of an equivalent elevated sign by a factor of 2.5 as shown in Figure A3-1. The shadowing, however, only affects the vertical dimension. Therefore, the spacing of characters for pavement marking is obtained by first determining the equivalent elevated sign character height and then proportioning from the spacing values given in Table A4-1. For example, in the case of the runway designator “10” which is to have a height of 4 000 mm (Hps), the equivalent elevated sign character height is  $4\ 000/2.5=1\ 600$  mm (Hes). Table A4-1(b) indicates numeral to numeral code 1 and from Table A4-1(c) this code has a dimension of 96 mm, for a character height of 400 mm. The pavement marking spacing for “10” is then  $(1\ 600/400) *96=384$  mm.

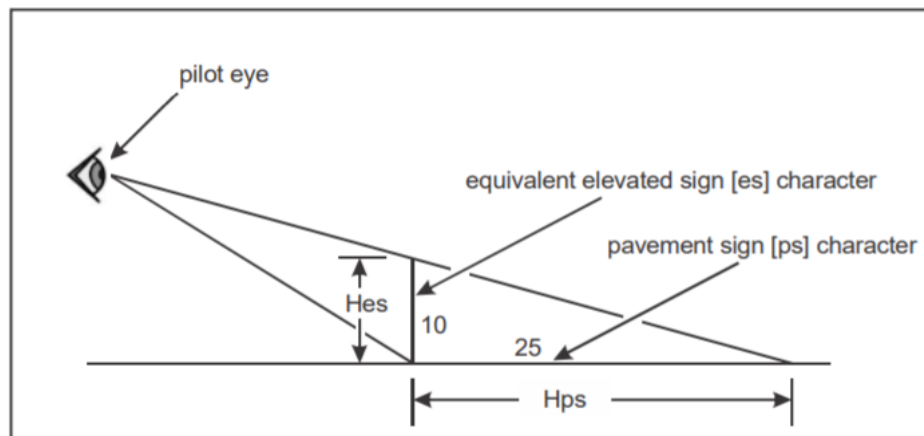
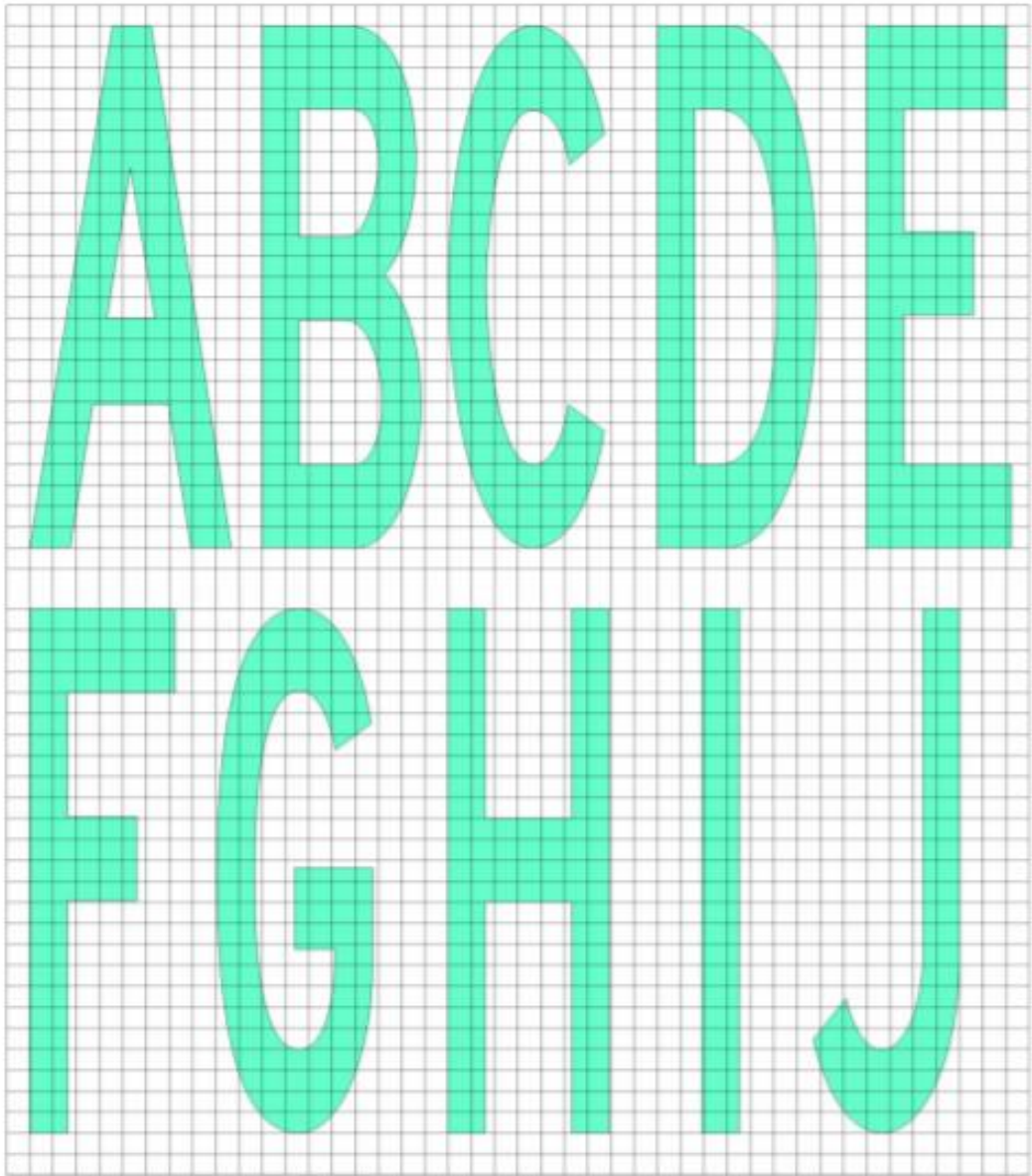
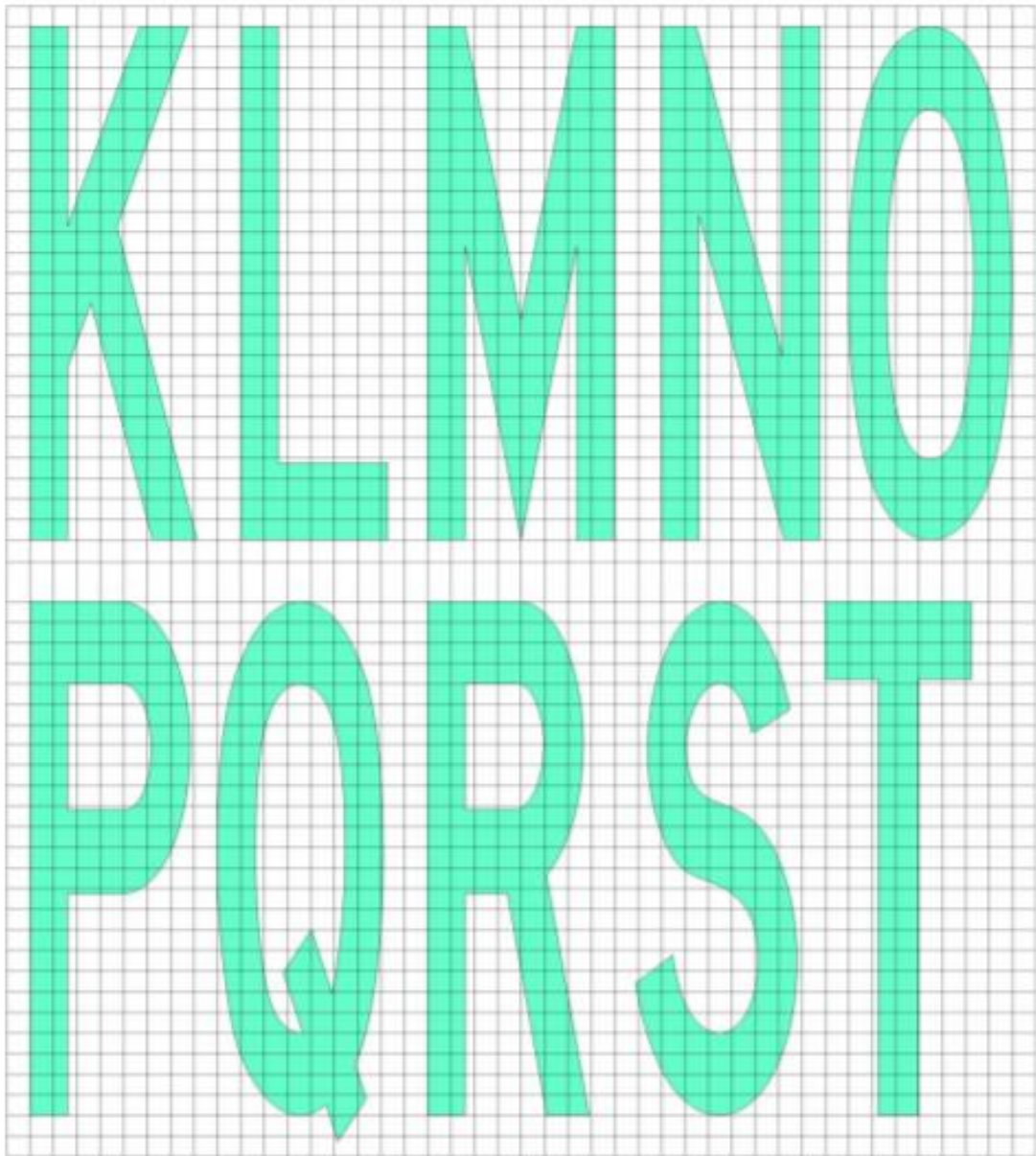
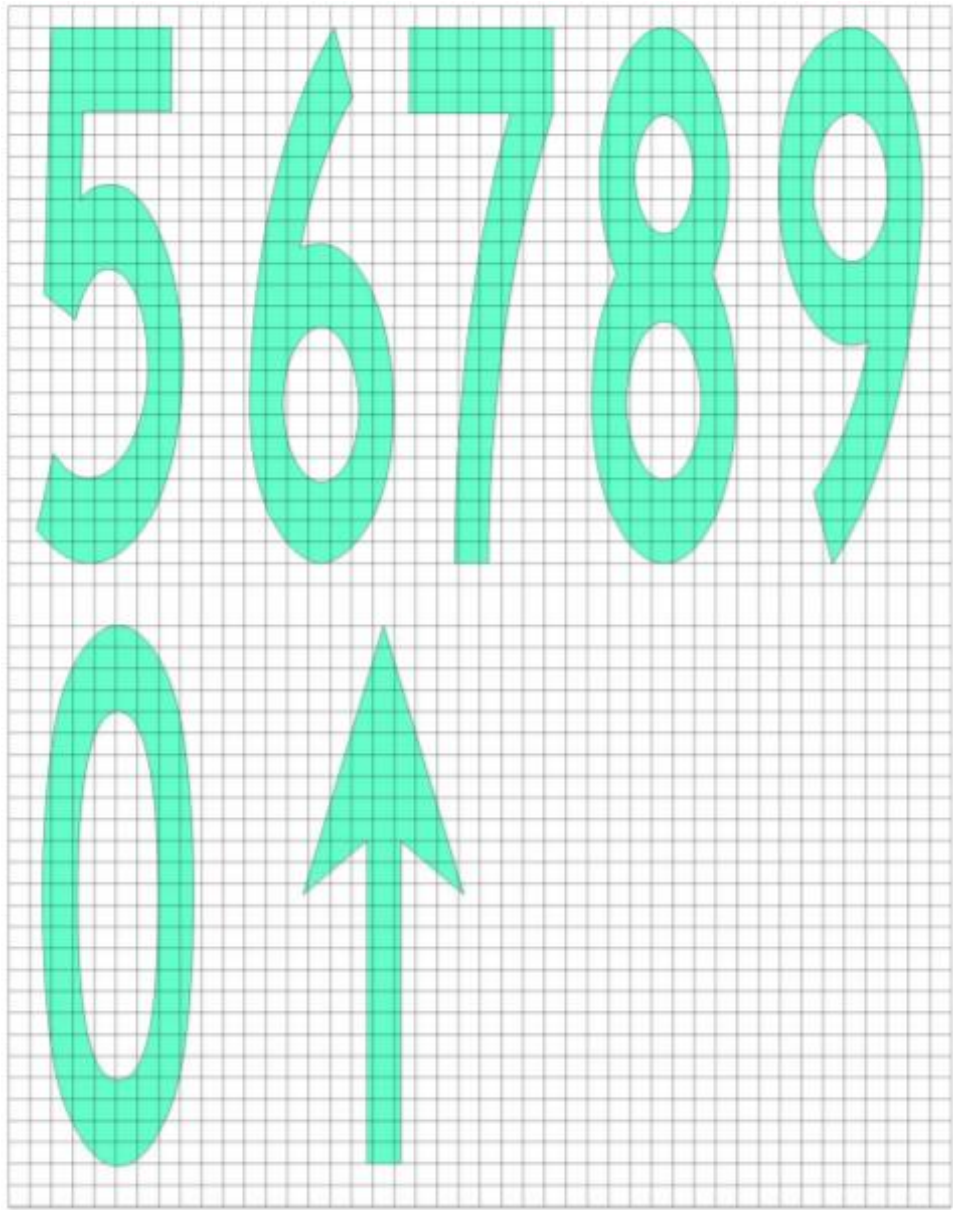

Figure A3-1









**SIXTH SCHEDULE**  
**Regulation**

**REQUIREMENTS CONCERNING DESIGN OF TAXIING GUIDANCE SIGNS**

1. Inscription heights shall conform to the following tabulation.

Runway code number	Minimum character height			
	Mandatory instruction sign	Information sign		
		Runway exit and runway vacated signs		Other signs
1 or 2	300 mm	300 mm		200 mm
3 or 4	400 mm	400 mm		300 mm

Note: Where a taxiway location sign is installed in conjunction with a runway designation sign (see regulation), the character size shall be that specified for mandatory instruction signs

2. Arrow dimensions shall be as follows:

Legend height	Stroke
200 mm	32 mm
300 mm	48 mm
400 mm	64 mm

3. Stroke width for single letter shall be as follows:

Legend height	Stroke
200 mm	32 mm
300 mm	48 mm
400 mm	64 mm

4. Sign luminance shall be as follows:

- (a) Where operations are conducted in runway visual range conditions less than a value of 800m, average sign luminance shall be at least:
  - Red 30 cd/m<sup>2</sup>
  - Yellow 150 cd/m<sup>2</sup>
  - White 300 cd/m<sup>2</sup>
- (b) Where operations are conducted in accordance with Regulation 147 (7) and 147 (8), average sign luminance shall be at least:

- Red 10 cd/m<sup>2</sup>
- Yellow 50 cd/m<sup>2</sup>
- White 100 cd/m<sup>2</sup>

Note: In runway visual range conditions less than a value of 400 m, there will be some degradation in the performance of signs.

- 5. The luminance ratio between red and white elements of a mandatory sign shall be between 1:5 and 1:10.
- 6. The average luminance of the sign is calculated by establishing grid points as shown in Figure B4-1 and using the luminance values measured at all grid points located within the rectangle representing the sign.
- 7. The average value is the arithmetic average of the luminance values measured at all considered grid points.

Note: Guidance on measuring the average luminance of a sign is contained in the Aerodrome Design Manual.

- 8. The ratio between luminance values of adjacent grid points shall not exceed 1.5:1. For areas on the sign face where the grid spacing is 7.5 cm, the ratio between luminance values of adjacent grid points shall not exceed 1.25:1. The ratio between the maximum and minimum luminance value over the whole sign face shall not exceed 5:1.
- 9. The forms of characters, i.e., letters, numbers, arrows and symbols, shall conform to those shown in Figure A4-2. The width of characters and the space between individual characters shall be determined as indicated in Table A4-1.
- 10. The face height of signs shall be as follows:

Legend height	Face height (min)
200 mm	300 mm
300 mm	450 mm
400 mm	600 mm

- 11. The face width of signs shall be determined using Figure A4-3 except that, where a mandatory instruction sign is provided on one side of a taxiway only, the face width shall not be less than:

- (a) 1.94 m where the code number is 3 or 4; and

- (b) 1.46 m where the code number is 1 or 2.

Note: Additional guidance on determining the face width of a sign is contained in the Aerodrome Design Manual,

12. Borders

- (a) The black vertical delineator between adjacent direction signs shall have a width of approximately 0.7 of the stroke widths.  
(b) The yellow border on a stand-alone location sign shall be approximately 0.5 stroke width

13. The colours of signs shall be in accordance with the appropriate specifications in Seventh Schedule.

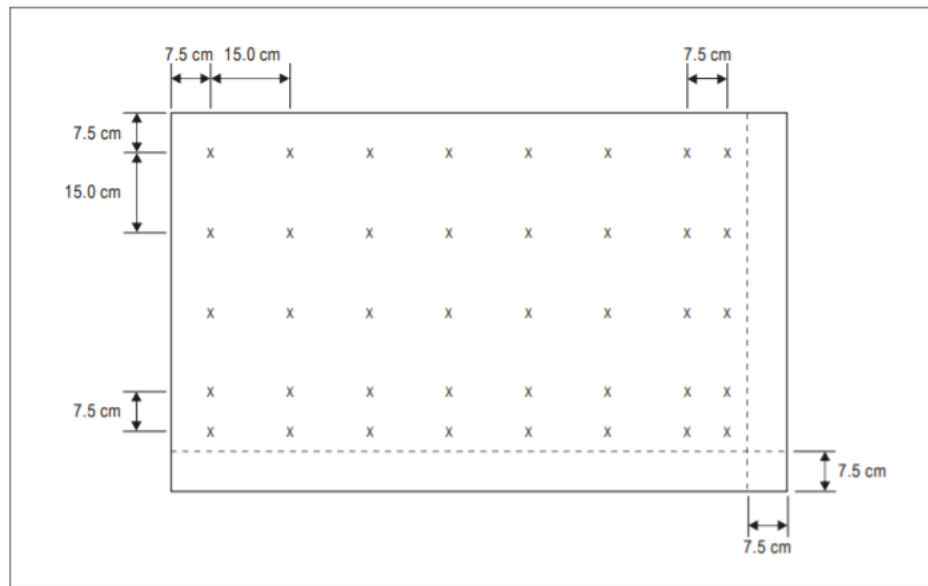

**Figure A4-1. Grid Points for Calculating Average Luminance of a Sign**

Note 1: The average luminance of a sign is calculated by establishing grid points on a sign face showing typical inscriptions and a background of the appropriate colour (red for mandatory instruction signs and yellow for direction and destination signs) as follows:

- (a) Starting at the top left corner of the sign face, establish a reference grid point at 7.5 cm from the left edge and the top of the sign face.  
(b) Create a grid of 15 cm spacing horizontally and vertically from the reference grid point. Grid points within 7.5 cm of the edge of the sign face shall be excluded.  
(c) Where the last point in a row/column of grid points is located between 22.5 cm and 15 cm from the edge of the sign face (but not inclusive), an additional point shall be added 7.5 cm from this point.  
(d) Where a grid point falls on the boundary of a character and the background, the

grid point Shall be slightly shifted to be completely outside the character.

Note 2: Additional grid points may be required to ensure that each character includes at least five evenly spaced grid points.

Note 3: Where one unit includes two types of signs, a separate grid shall be established for each type.

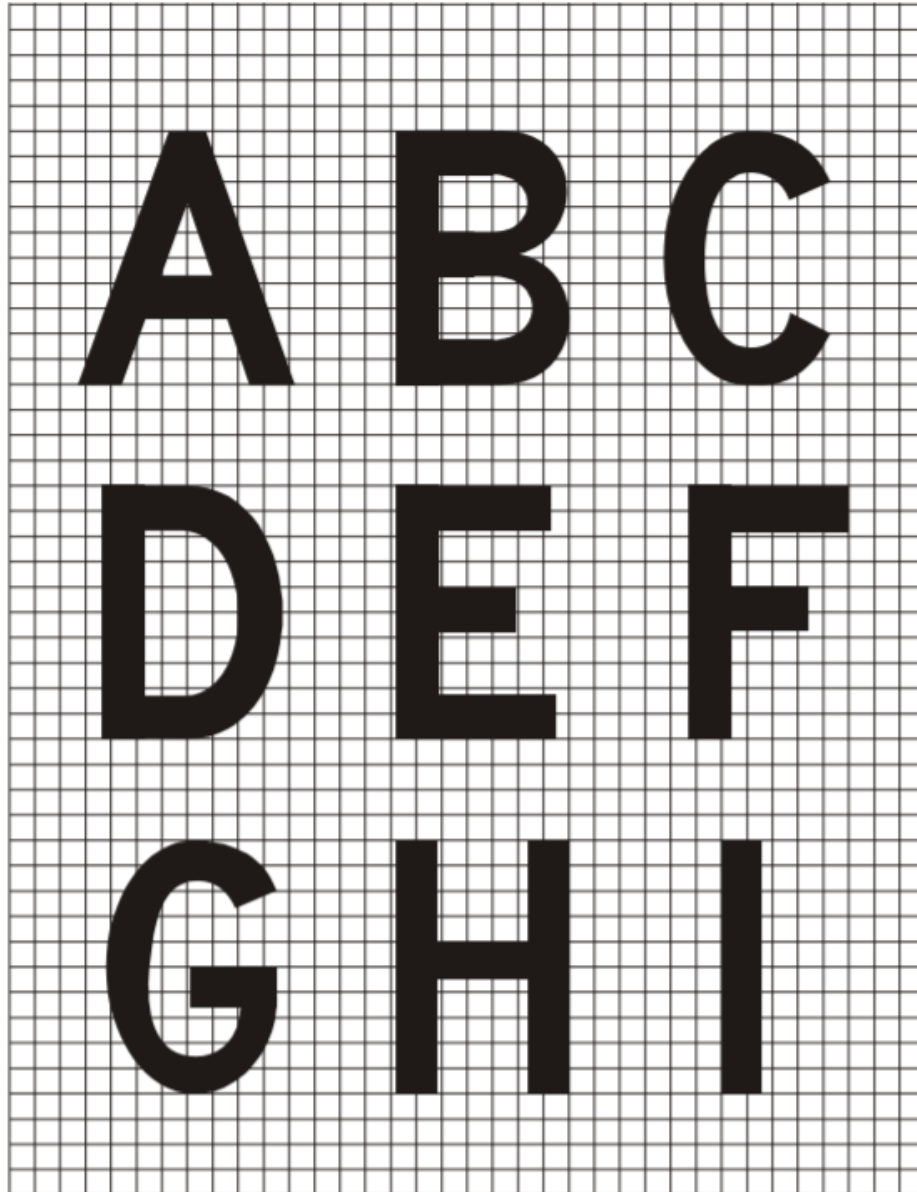

**Figure A4-2. Forms of characters**

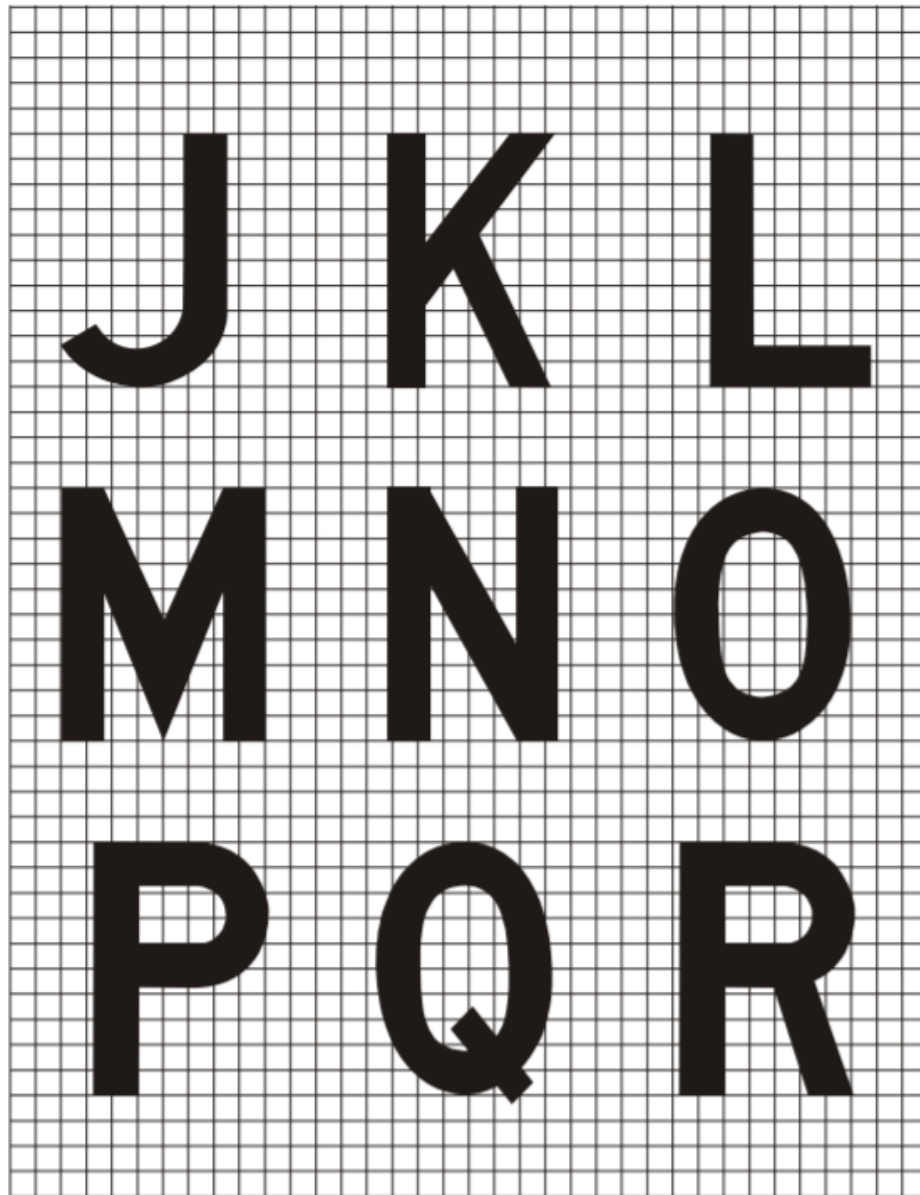

**Figure A4-2. (cont.)**

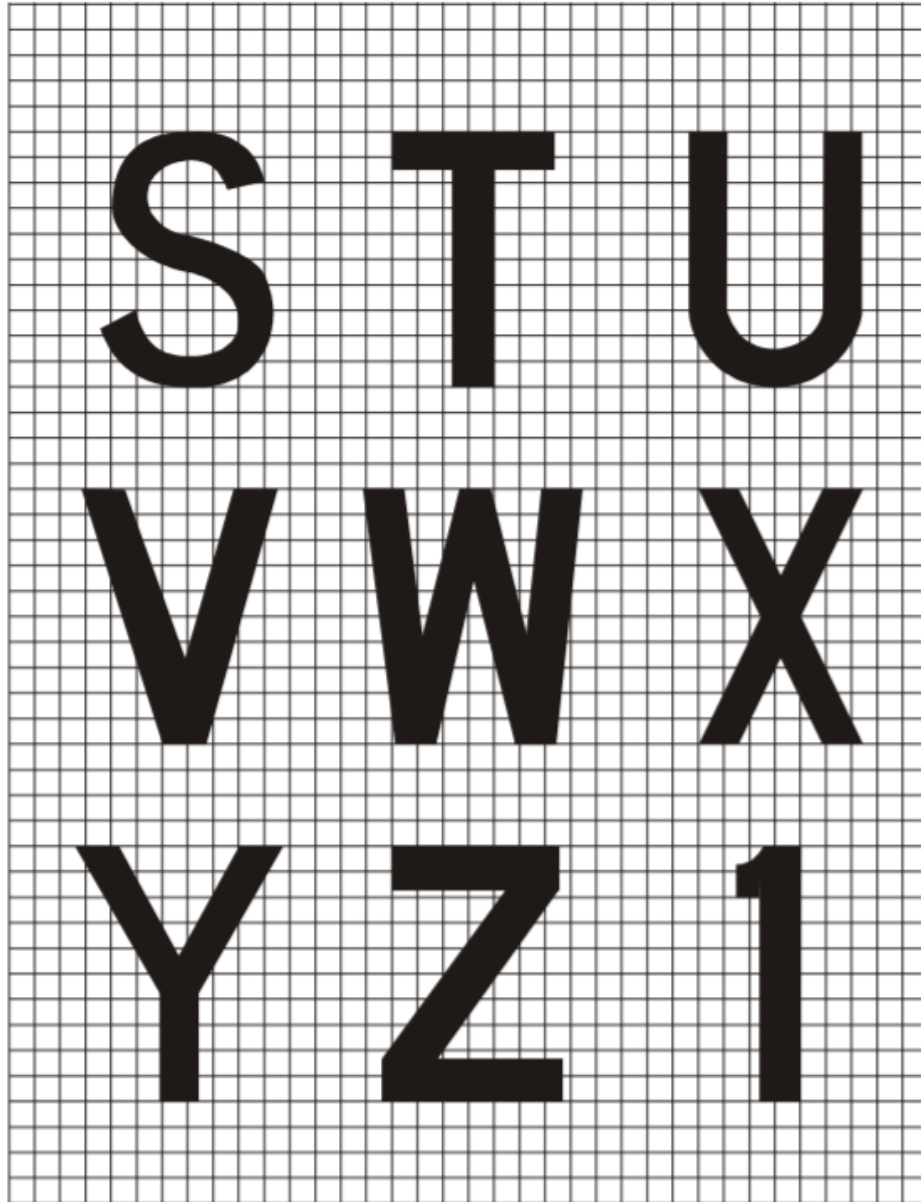

**Figure A4-2. (cont.)**

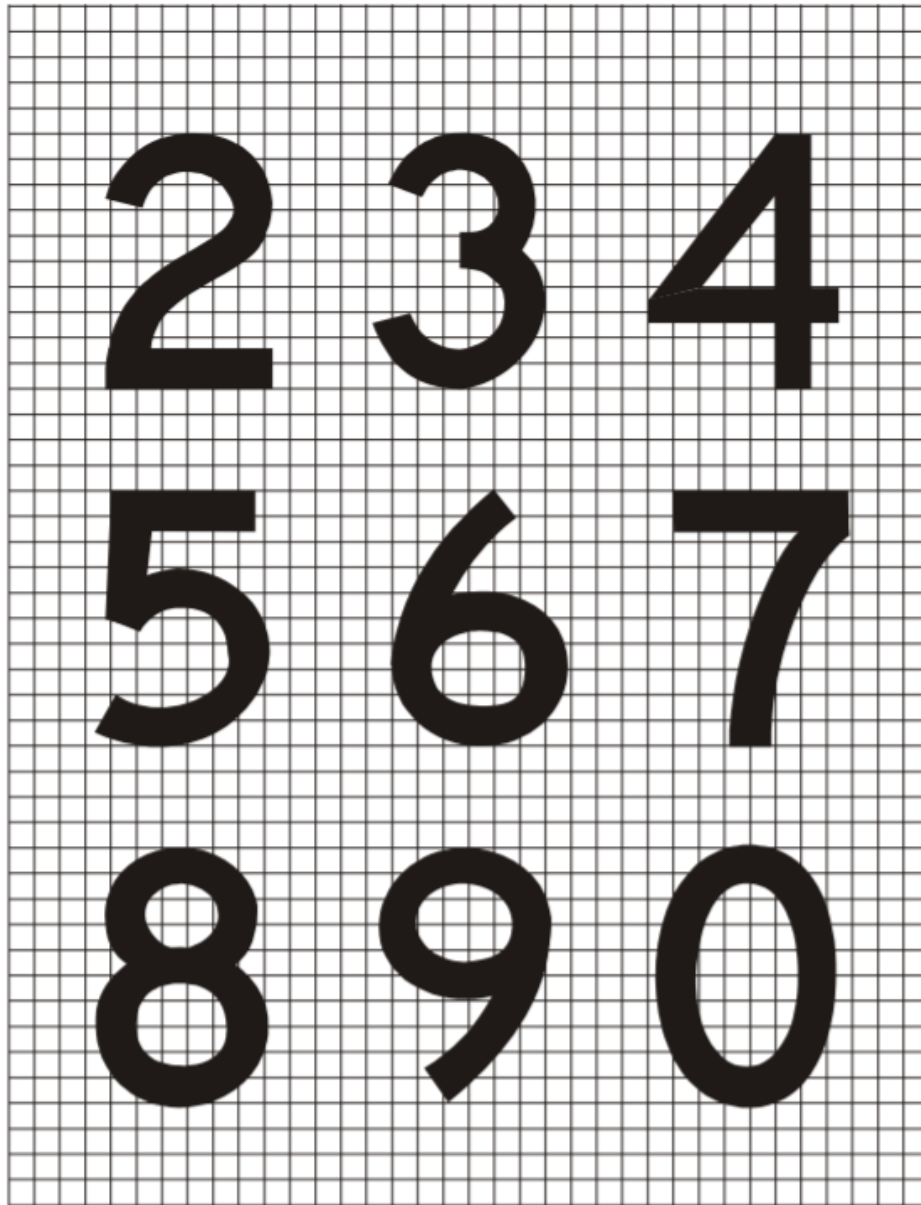

**Figure A4-2. (cont.)**

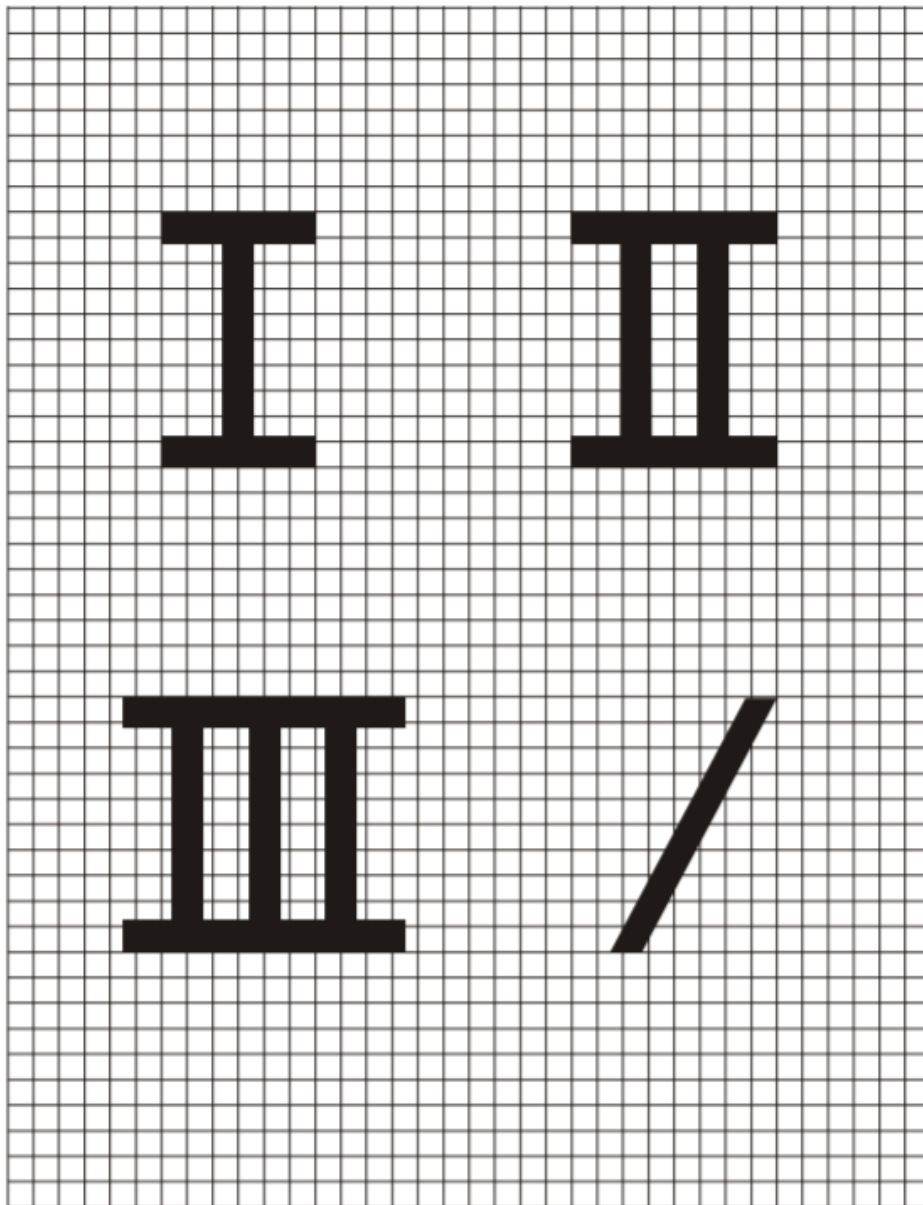
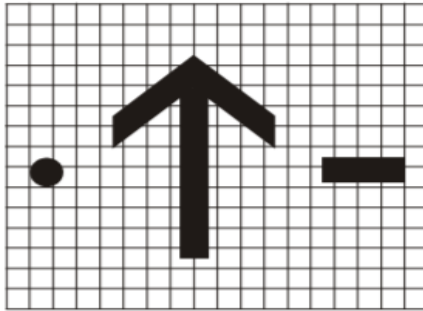
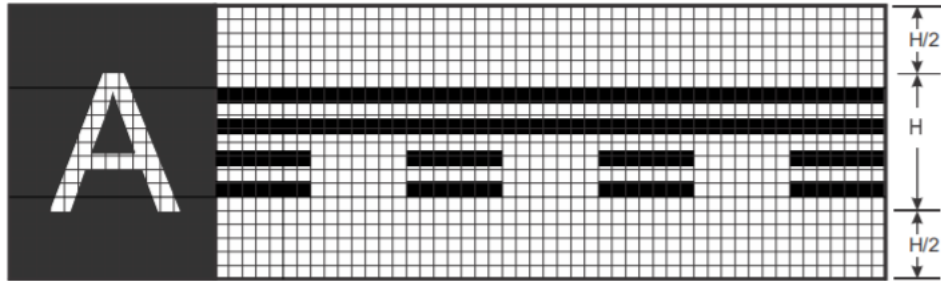

Figure A4-2. (cont.)



Note 1. —The arrow stroke width, diameter of the dot, and both width and length of the dash shall be proportioned to the character stroke widths.  
 Note 2.— The dimensions of the arrow shall remain constant for a particular sign size, regardless of orientation.

**Figure A4-2.**



**Runway vacated sign (with typical location sign)**

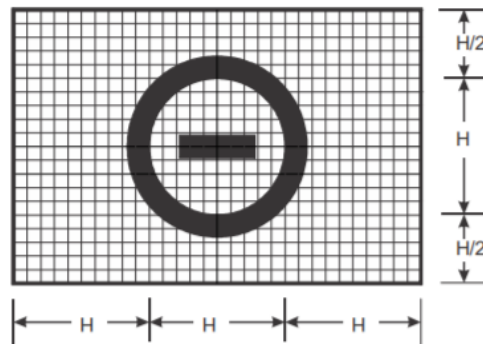

**Figure A4-3. Runway vacated and NO ENTRY signs**

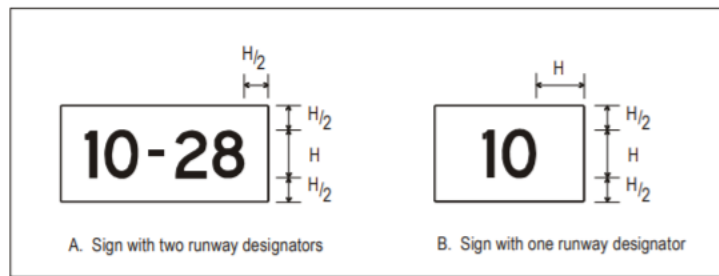

**Figure A4-3. Sign dimensions**

**Table A4-1. Letter and numeral widths and space between letters or numerals**

a) Letter to letter code number				b) Width of letter			
Preceding letter	Following Letter			Letter	Letter height (mm)		
	B, D, E, F, H, I, K, L, M, N, P, R, U	C, G, O, Q, S, X, Z	A, J, T, V, W, Y		200	300	400
	Code number			Width (mm)			
A	2	2	4	A	170	255	340
B	1	2	2	B	137	205	274
C	1	2	3	C	137	205	274
D	1	2	2	D	137	205	274
E	1	2	3	E	124	186	248
F	1	2	3	F	124	186	248
G	1	2	2	G	137	205	274
H	1	1	2	H	137	205	274
I	1	1	2	I	32	48	64
J	1	1	2	J	127	190	254
K	1	2	3	K	140	210	280
L	1	2	4	L	124	186	248
M	1	1	2	M	157	236	314
N	1	1	2	N	137	205	274
O	1	2	2	O	143	214	286
P	1	2	2	P	137	205	274
Q	1	2	2	Q	143	214	286
R	1	2	2	R	137	205	274
S	1	2	2	S	137	205	274
T	2	2	4	T	124	186	248
U	2	1	2	U	137	205	274
V	2	2	4	V	152	229	304
				W	178	267	356

W	2	2	4
X	2	2	3
Y	2	2	4
Z	2	2	3

d) Numerical to numerical code number

Preceding numeral	Following number		
	1, 5	2, 3, 6, 8, 9, 0	4, 7
	Code number		
1	1	1	2
2	1	2	2
3	1	2	2
4	2	2	4
5	1	2	2
6	1	2	2
7	2	2	4
8	1	2	2
9	1	2	2
0	1	2	2

e) Space between characters

Code No.	Character height (mm)		
	200	300	400
	Space (mm)		
	48	71	96
	38	57	76
	25	38	50
	13	19	26

X	137	205	274
Y	171	257	342
Z	137	205	274

c) Width of runways

Numeral	Numeral height (mm)		
	200	300	400
	Width (mm)		
1	60	74	98
2	137	205	274
3	137	205	274
4	149	224	298
5	137	205	274
6	137	205	274
7	137	205	274
8	137	205	274
9	137	205	274
0	143	214	286

### INSTRUCTIONS

- To determine the proper SPACE between letters or numerals, obtain the code number from table (a) or (b) and enter table c) for that code number to the desired letter or numeral height.
- The space between words or groups of characters forming an abbreviation or symbol should be equal to 0.5 to 0.75 of the height of the characters used except that where an arrow is located with a single character such as 'A □', the space may be reduced to not less than one quarter of the height of the character in order to provide a good visual balance.
- Where the numeral follows a letter or vice versa use Code 1.
- Where a hyphen, dot, or diagonal stroke follows a character or vice versa use Code 1.

5. For the intersection take-off sign, the height of the lower case “m” is 0.75 of the height of the preceding “0” (zero) and spaced from the preceding “0” at code 1 for the character height of the numerals.

**SEVENTH SCHEDULE**  
**Regulation 164**  
**LOCATION OF LIGHTS ON OBSTACLES**

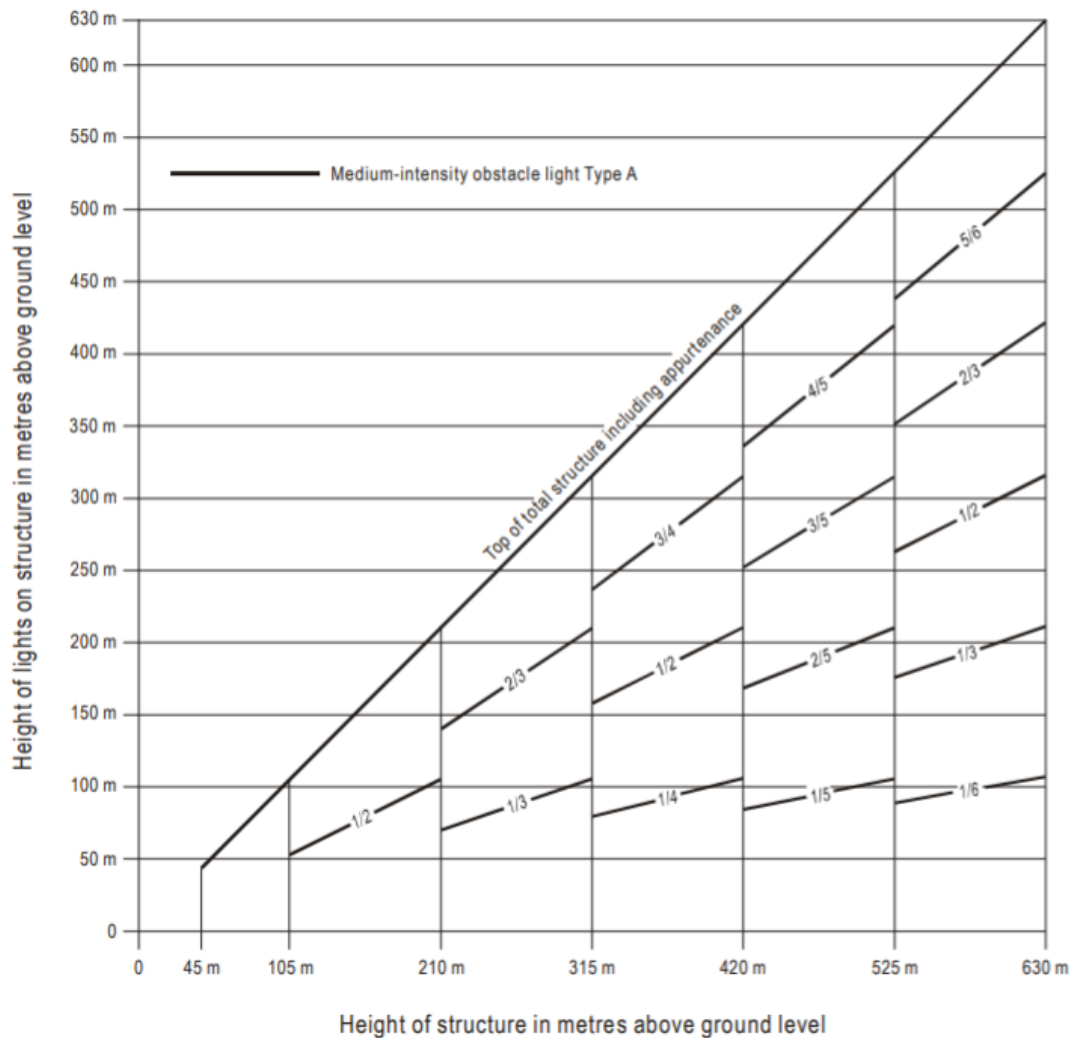

Note: High-intensity obstacle lighting is recommended on structures with a height of more than 150 m above ground level. Where medium-intensity lighting is used, marking will also be required.

**Figure A5-1. Medium-Intensity Flashing-White Obstacle Lighting System, Type A**

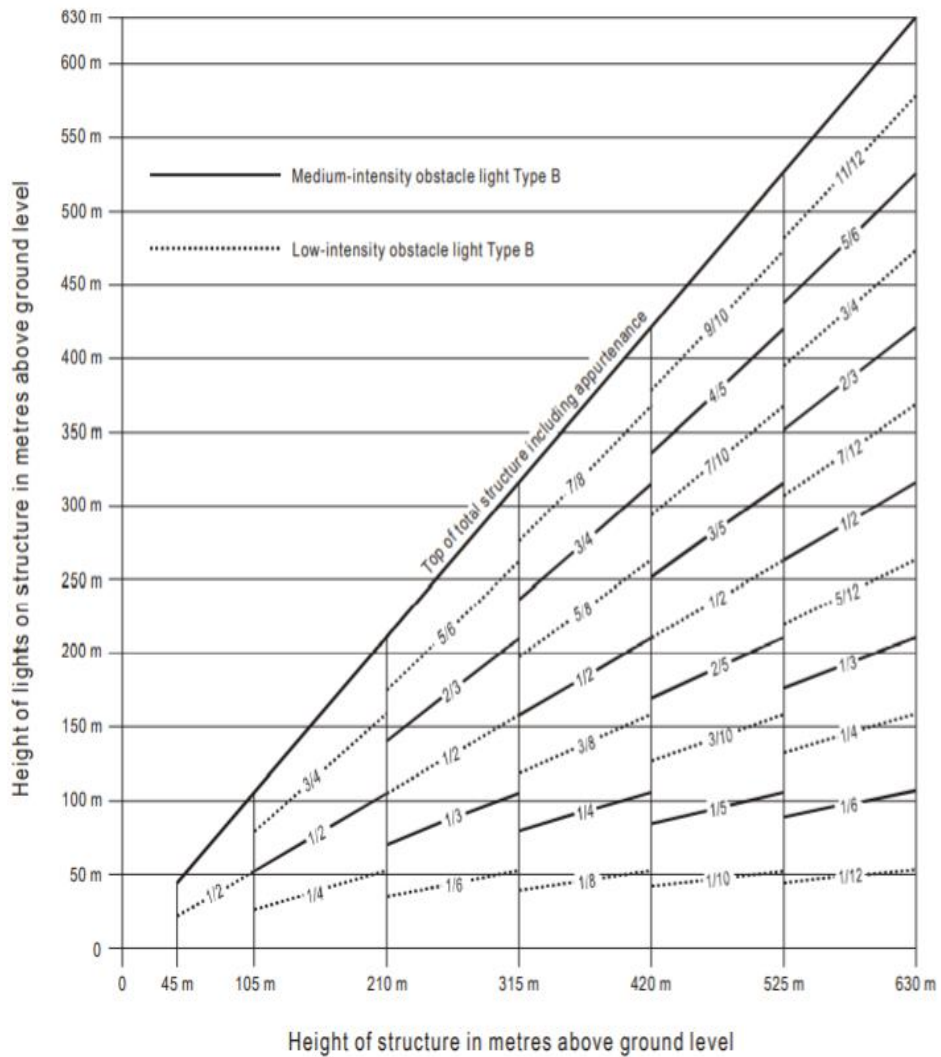

Note. — For night-time use only.

**Figure A5-2. Medium-Intensity Flashing-Red Obstacle Lighting System, Type B**

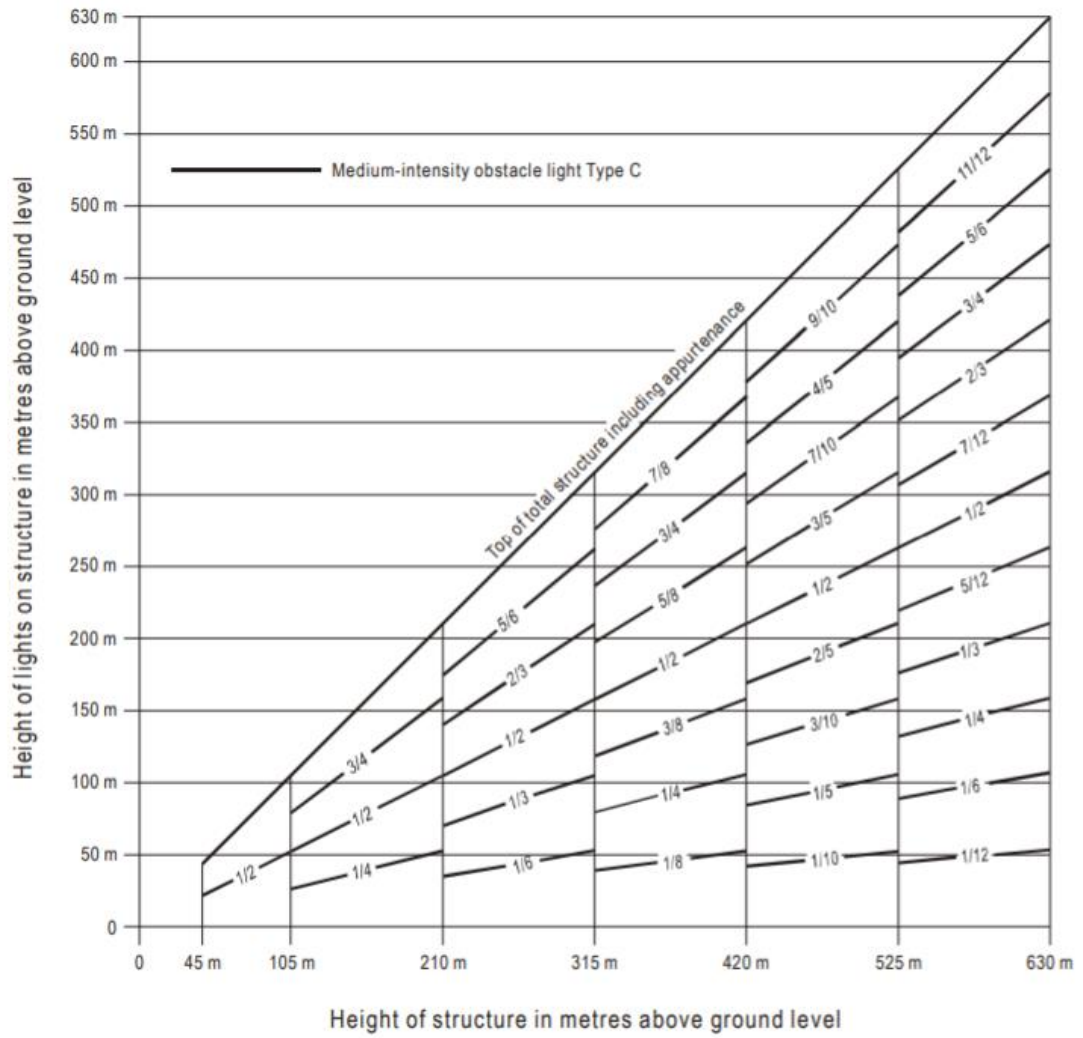

Height of structure in metres above ground level

Note: For night-time use only.

**Figure A5-3. Medium-Intensity Fixed-Red Obstacle Lighting System, Type C**

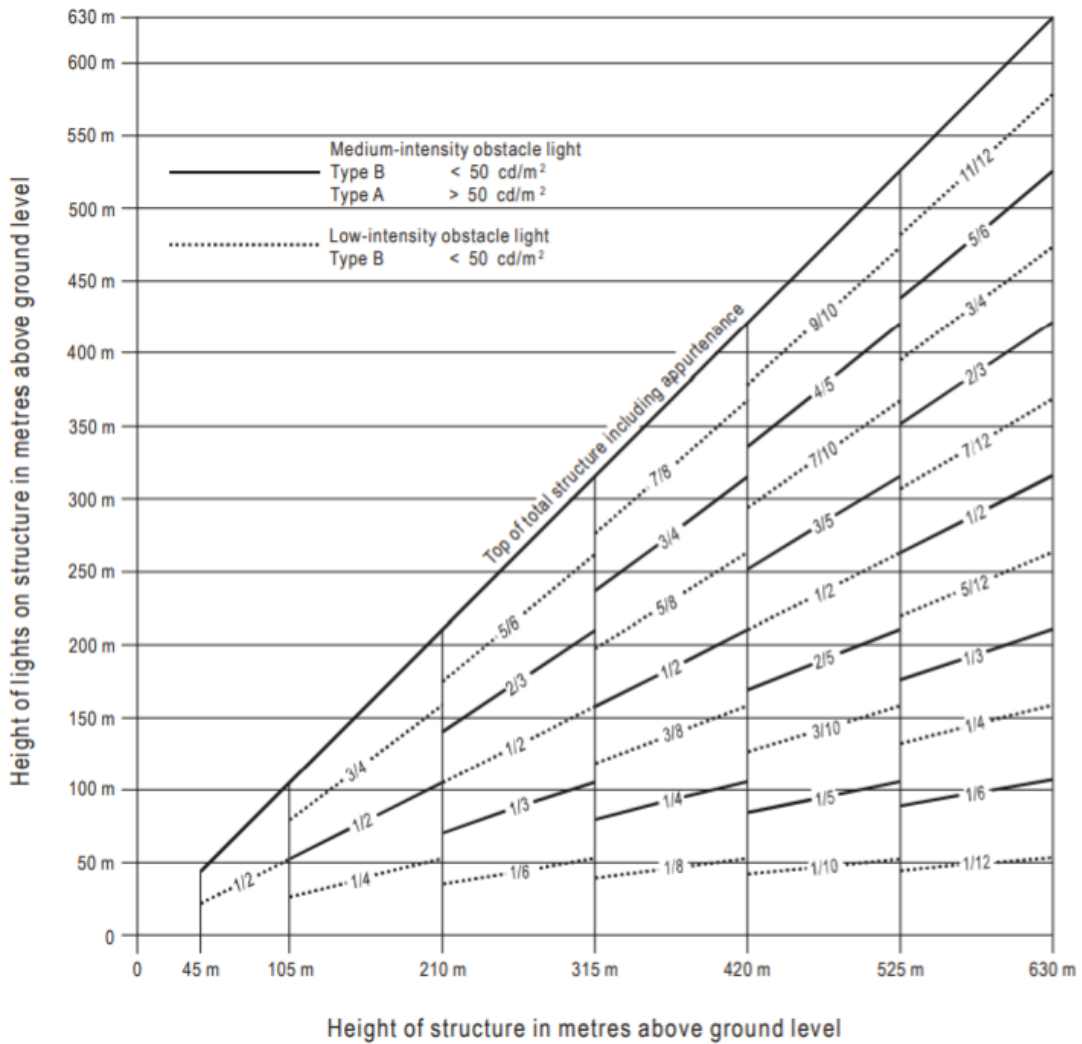

Note. — High-intensity obstacle lighting is recommended on structures with a height of more than 150 m above ground level. Where medium-intensity lighting is used, marking will also be required.

**Figure A5-4. Medium-Intensity Dual Obstacle Lighting System, Type A/Type B**

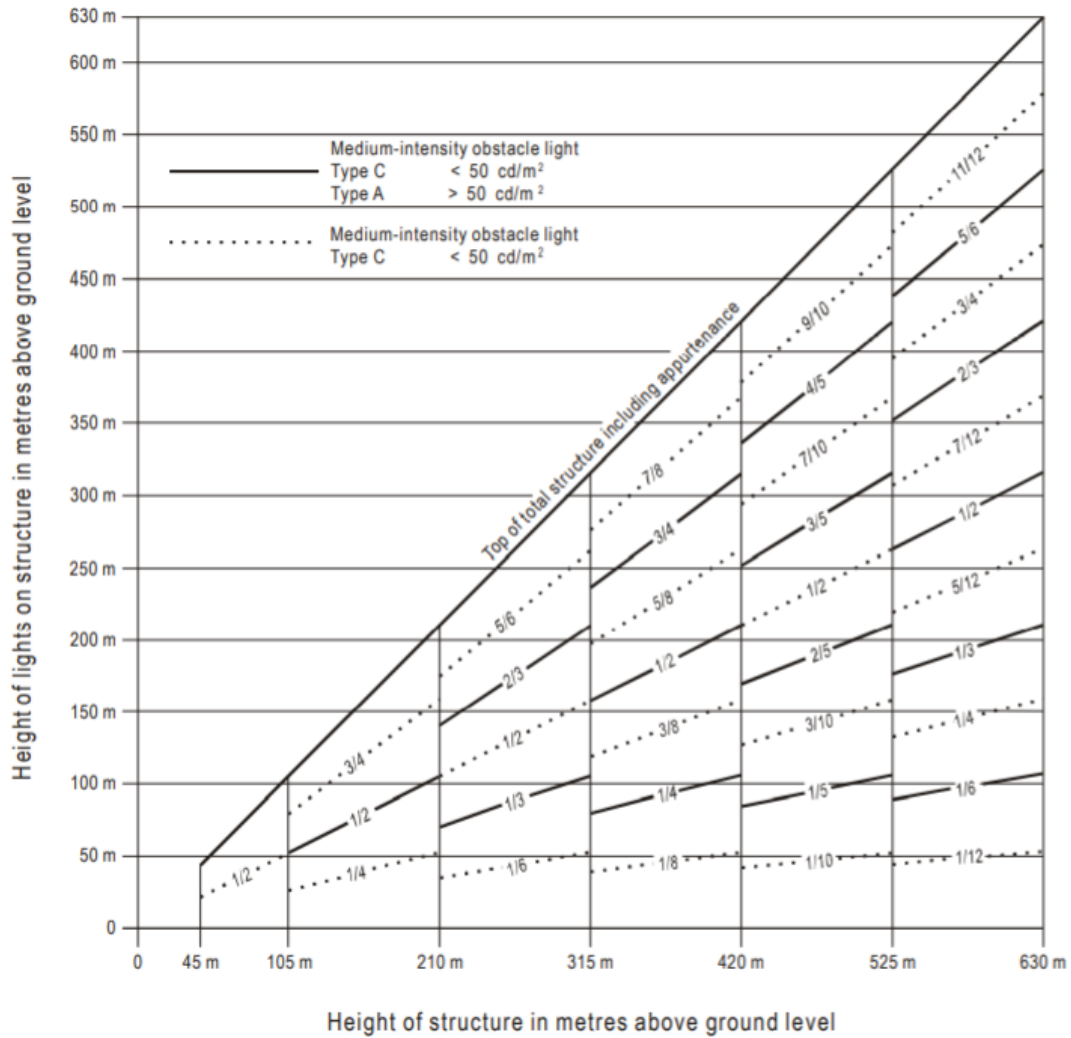

Note: High-intensity obstacle lighting is recommended on structures with a height of more than 150 m above ground level. Where medium-intensity lighting is used, marking will also be required.

**Figure A5-5. Medium-Intensity Dual Obstacle Lighting System, Type A/Type C**

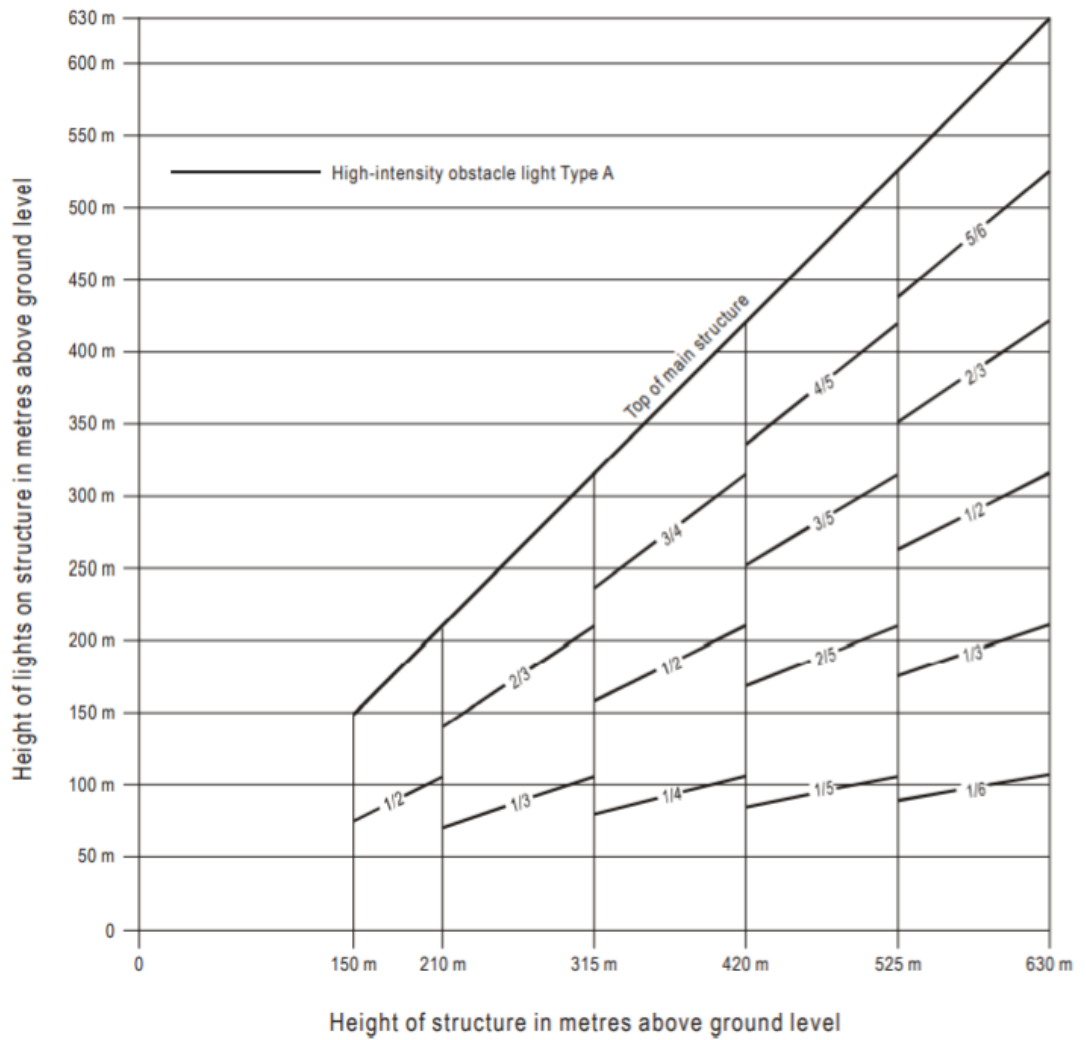

**Figure A5-6. High-Intensity Flashing-White Obstacle Lighting System, Type A**

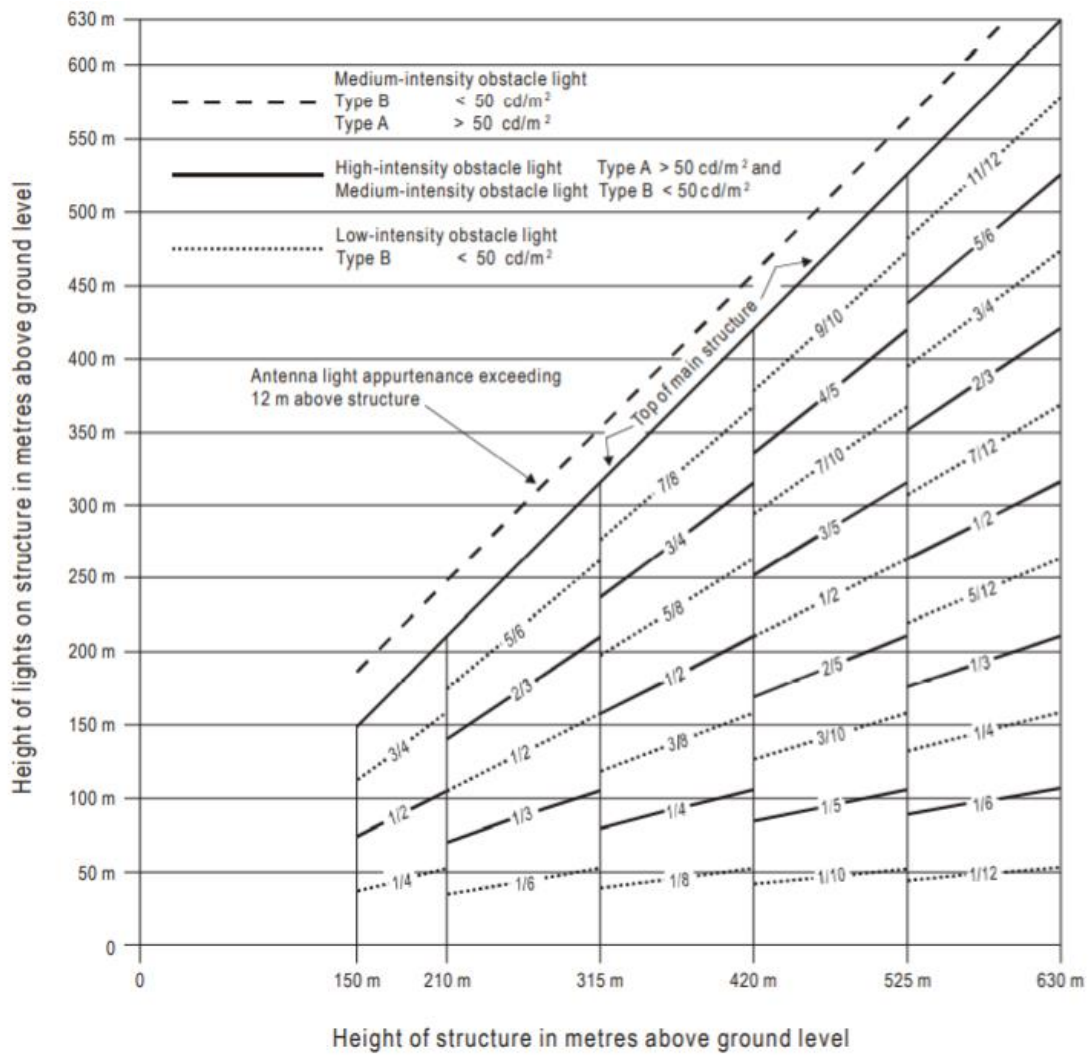

**Figure A5-7. High-/Medium-Intensity Dual Obstacle Lighting System, Type A/Type B**

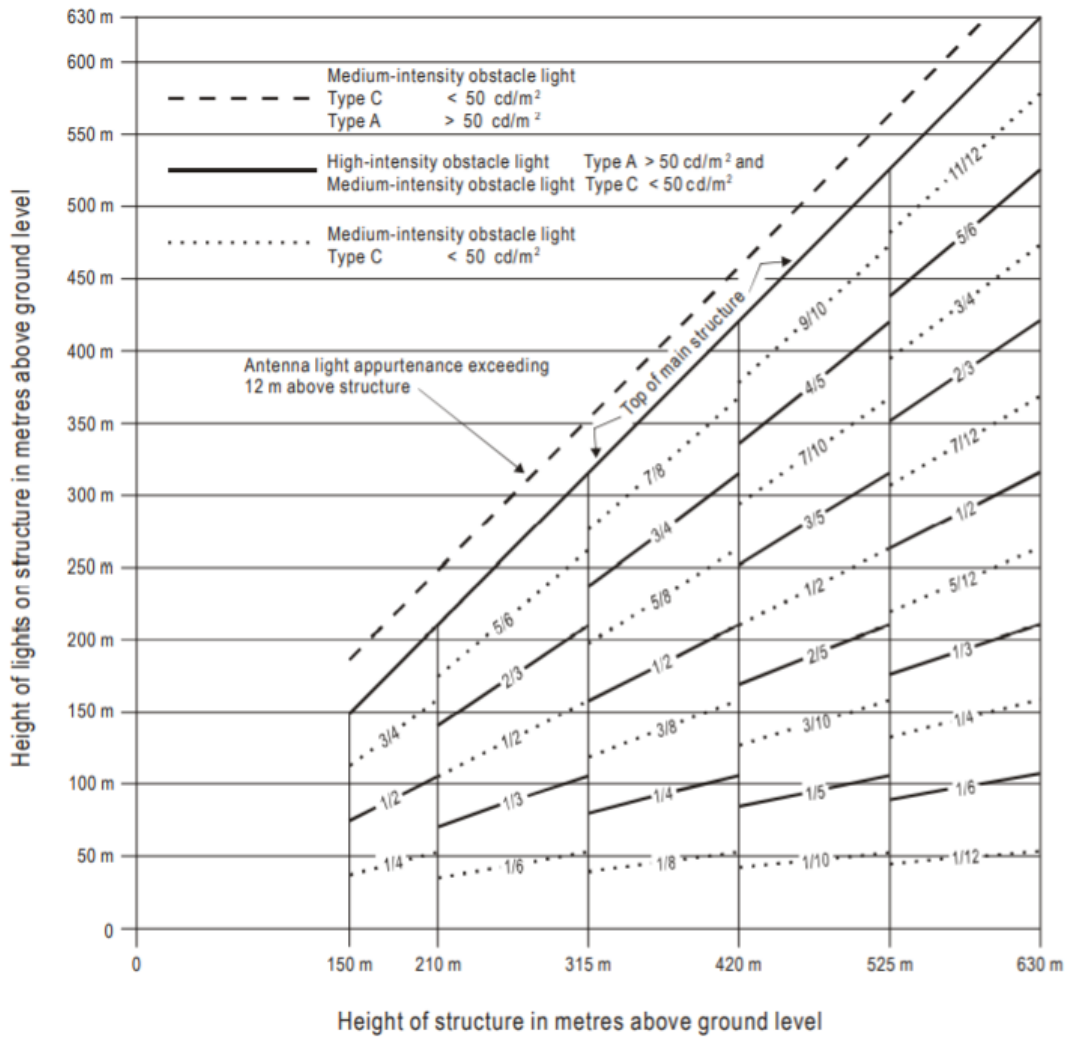

**Figure A5-8. High-/Medium-Intensity Dual Obstacle Lighting System, Type A/Type C**

## **EIGHTH SCHEDULE**

### **Regulation 26, 27, 38**

#### **GUIDANCE MATERIAL SUPPLEMENTARY TO THE CIVIL AVIATION (AERODROMES) REGULATIONS**

##### **1. Number, Siting and Orientation of Runways**

###### **Siting And Orientation of Runways**

- 1.1 Many factors shall be taken into account in the determination of the siting and orientation of runways. Without attempting to provide an exhaustive list of these factors or an analysis of their effects, it appears useful to indicate those which most frequently require study. These factors may be classified under four headings:
- 1.1.1 Type of operation. Attention shall be paid in particular to whether the aerodrome is to be used in all meteorological conditions or only in visual meteorological conditions, and whether it is intended for use by day and night, or only by day.
- 1.1.2 Climatological conditions. A study of the wind distribution shall be made to determine the usability factor. In this regard, the following comments shall be taken into account:
- (a) Wind statistics used for the calculation of the usability factor are normally available in ranges of speed and direction, and the accuracy of the results obtained depends, to a large extent, on the assumed distribution of observations within these ranges. In the absence of any sure information as to the true distribution, it is usual to assume a uniform distribution since, in relation to the most favorable runway orientations, this generally results in a slightly conservative for the usability factor.
  - (b) The maximum mean cross-wind components given in Part V, Regulation 35 refer to normal circumstances. There are some factors which may require that a reduction of those maximum values be taken into account at a particular aerodrome. These include:
    - (i) the wide variations which may exist, in handling characteristics and maximum permissible cross-wind components, among diverse types of aeroplanes (including future types) within each of the three groups given in Regulation 35;
    - (ii) prevalence and nature of gusts;
    - (iii) prevalence and nature of turbulence;
    - (iv) the availability of a secondary runway;
    - (v) the width of runways;
      - (1) the runway surface conditions — water, snow and ice on the runway materially reduce the allowable crosswind component; and

- (2) the strength of the wind associated with the limiting cross-wind component. A study shall also be made of the occurrence of poor visibility and/or low cloud base. Account shall be taken of their frequency as well as the accompanying wind direction and speed.

- 1.1.3 Topography of the aerodrome site, its approaches, and surroundings, particularly:
  - (a) compliance with the obstacle limitation surfaces;
  - (b) current and future land use. The orientation and layout shall be selected so as to protect as far as possible the particularly sensitive areas such as residential, school and hospital zones from the discomfort caused by aircraft noise. Detailed information on this topic is provided in the Airport Planning Manual, Part 2, and in Guidance on the Balanced Approach to Aircraft Noise Management (Doc 9829);
  - (c) current and future runway lengths to be provided;
  - (d) construction costs; and
  - (e) possibility of installing suitable non-visual and visual aids for approach-to-land.
- 1.1.4 Air traffic in the vicinity of the aerodrome, particularly:
  - (a) proximity of other aerodromes or ATS routes;
  - (b) traffic density; and
  - (c) air traffic control and missed approach procedures. Number of runways in each direction
- 1.2 The number of runways to be provided in each direction depends on the number of aircraft movements to be catered to.

## **2. Clearways and Stop Ways**

- 2.1 The decision to provide a stop way and/or a clearway as an alternative to an increased length of runway will depend on the physical characteristics of the area beyond the runway end, and on the operating performance requirements of the prospective Aeroplan. The runway, stopway and clearway lengths to be provided are determined by the Aeroplan takeoff performance, but a check shall also be made of the landing distance required by the Aeroplan using the runway to ensure that adequate runway length is provided for landing. The length of a clearway, however, cannot exceed half the length of take-off run available.
- 2.2 The Aeroplane performance operating limitations require a length which is enough to ensure that the aeroplane can, after starting a take-off, either be brought safely to a stop or complete the take-off safely. For the purpose of discussion, it is supposed that the runway, stopway and clearway lengths provided at the aerodrome are only just adequate for the aeroplane requiring the longest take-off and accelerate-stop distances, taking into account its take-off mass, runway

characteristics and ambient atmospheric conditions. Under these circumstances there is, for each take-off, a speed, called the decision speed; below this speed, the take-off must be abandoned where an engine fails, while above it the take-off must be completed. A very long take-off run and take-off distance will be required to complete a take-off when an engine fails before the decision speed is reached, because of the insufficient speed and the reduced power available. There will be no difficulty in stopping in the remaining accelerate stop distance available provided action is taken immediately. In these circumstances the correct course of action will be to abandon the take-off.

- 2.3 On the other hand, where an engine fails after the decision speed is reached, the aeroplane will have sufficient speed and power available to complete the take-off safely in the remaining take-off distance available. However, because of the high speed, there will be difficulty in stopping the aeroplane in the remaining accelerate-stop distance available.
- 2.4 The decision speed is not a fixed speed for any aeroplane, but can be selected by the pilot within limits to suit the accelerate-stop and take-off distance available, aeroplane take-off mass, runway characteristics, and ambient atmospheric conditions at the aerodrome. Normally, a higher decision speed is selected as the accelerate-stop distance available increases.
- 2.5 A variety of combinations of accelerate-stop distances required and take-off distances required can be obtained to accommodate a particular aeroplane, taking into account the aeroplane take-off mass, runway characteristics, and ambient atmospheric conditions. Each combination requires its particular length of take-off run.
- 2.6 The most familiar case is where the decision speed is such that the take-off distance required is equal to the accelerate-stop distance required; this value is known as the balanced field length. Where stop way and clearway are not provided, these distances are both equal to the runway length. However, where landing distance is for the moment ignored, runway is not essential for the whole of the balanced field length, as the take-off run required is, of course, less than the balanced field length. The balanced field length can, therefore, be provided by a runway supplemented by an equal length of clearway and stop way, instead of wholly as a runway. Where the runway is used for take-off in both directions, an equal length of clearway and stop way has to be provided at each runway end. The saving in runway length is, therefore, bought at the cost of a greater overall length.
- 2.7 In case economic considerations preclude the provision of stop way and, as a result, only runway and clearway are to be provided, the runway length (neglecting landing requirements) shall be equal to the accelerate-stop distance required or the

take-off run required, whichever is the greater. The take-off distance available will be the length of the runway plus the length of clearway.

- 2.8 The minimum runway length and the maximum stop way or clearway length to be provided may be determined as follows, from the data in the aeroplane flight manual for the aeroplane considered to be critical from the viewpoint of runway length requirements:
- (a) where a stop way is economically possible, the lengths to be provided are those for the balanced field length. The runway length is the take-off run required or the landing distance required, whichever is the greater. Where the accelerate-stop distance required is greater than the runway length so determined, the excess may be provided as stop way, usually at each end of the runway. In addition, a clearway of the same length as the stop way must also be provided;
  - (b) where a stop way is not to be provided, the runway length is the landing distance required, or where it is greater, the accelerate-stop distance required, which corresponds to the lowest practical value of the decision speed. The excess of the take-off distance required over the runway length may be provided as clearway, usually at each end of the runway.
- 2.9 In addition to the above consideration, the concept of clearways in certain circumstances can be applied to a situation where the take-off distance required for all engines operating exceeds that required for the engine failure case.
- 2.10 The economy of a stop way can be entirely lost if, after each usage, it must be re-graded and compacted. Therefore, it shall be designed to withstand at least a certain number of loadings of the aeroplane which the stop way is intended to serve without inducing structural damage to the aeroplane.

### **3. Calculation of Declared Distances**

- 3.1 The declared distances to be calculated for each runway direction comprise: the take-off run available (TORA), take-off distance available (TODA), accelerate-stop distance available (ASDA), and landing distance available (LDA).
- 3.2 Where a runway is not provided with a stop way or clearway and the threshold is located at the extremity of the runway, the four declared distances shall normally be equal to the length of the runway, as shown in Figure B-1 (A).
- 3.3 Where a runway is provided with a clearway (CWY), then the TODA will include the length of clearway, as shown in Figure B-1 (B).
- 3.4 Where a runway is provided with a stop way (SWY), then the ASDA will include the length of stop way, as shown in Figure B-1 (C).

- 3.5 Where a runway has a displaced threshold, then the LDA will be reduced by the distance the threshold is displaced, as shown in Figure B-1 (D). A displaced threshold affects only the LDA for approaches made to that threshold; all declared distances for operations in the reciprocal direction are unaffected.
- 3.6 Figures B-1 (B) through B-1 (D) illustrate a runway provided with a clearway or a stop way or having a displaced threshold. Where more than one of these features exist, then more than one of the declared distances will be modified — but the modification will follow the same principle illustrated. An example showing a situation where all these features exist is shown in Figure B-1 (E).
- 3.7 A suggested format for providing information on declared distances is given in Figure B-1 (F). Where a runway direction cannot be used for take-off or landing, or both, because it is operationally forbidden, then this shall be declared and the words “not usable” or the abbreviation “NU” entered.

#### 4. Slopes On a Runway

- 4.1 Distance between slope changes.

The following example illustrates how the distance between slope changes is to be determined (see Figure B-2):

D for a runway where the code number is 3 shall be at least:

$$15\,000 (|x - y| + |y - z|) \text{ m}$$

$|x - y|$  being the absolute numerical value of  $x - y$

$|y - z|$  being the absolute numerical value of  $y - z$

Assuming  $x = +0.01$

$$y = -0.005$$

$$z = +0.005$$

then  $|x - y| = 0.015$

$$|y - z| = 0.01$$

To comply with the specifications, D shall be not less than:

$$15\,000 (0.015 + 0.01) \text{ m,}$$

that is,  $15\,000 \times 0.025 = 375 \text{ m}$

- 4.2 Consideration of longitudinal and transverse slopes When a runway is planned that will combine the extreme values for the slopes and changes in slope permitted under this Regulation, a study shall be made to ensure that the resulting surface profile will not hamper the operation of aeroplanes.
- 4.3 Radio altimeter operating area In order to accommodate aeroplanes making auto-coupled approaches and automatic landings (irrespective of weather conditions) it

is desirable that slope changes be avoided or kept to a minimum, on a rectangular area at least 300 m long before the threshold of a precision approach runway. The area shall be symmetrical about the extended center line, 120 m wide. When special circumstances so warrant, the width may be reduced to no less than 60 m where an aeronautical study indicates that such reduction will not affect the safety of operations of aircraft. This is desirable because these aeroplanes are equipped with a radio altimeter for final height and flare guidance, and when the aeroplane is above the terrain immediately prior to the threshold, the radio altimeter will begin to provide information to the automatic pilot for auto flare. Where slope changes cannot be avoided, the rate of change between two consecutive slopes shall not exceed 2 per cent per 30 m.

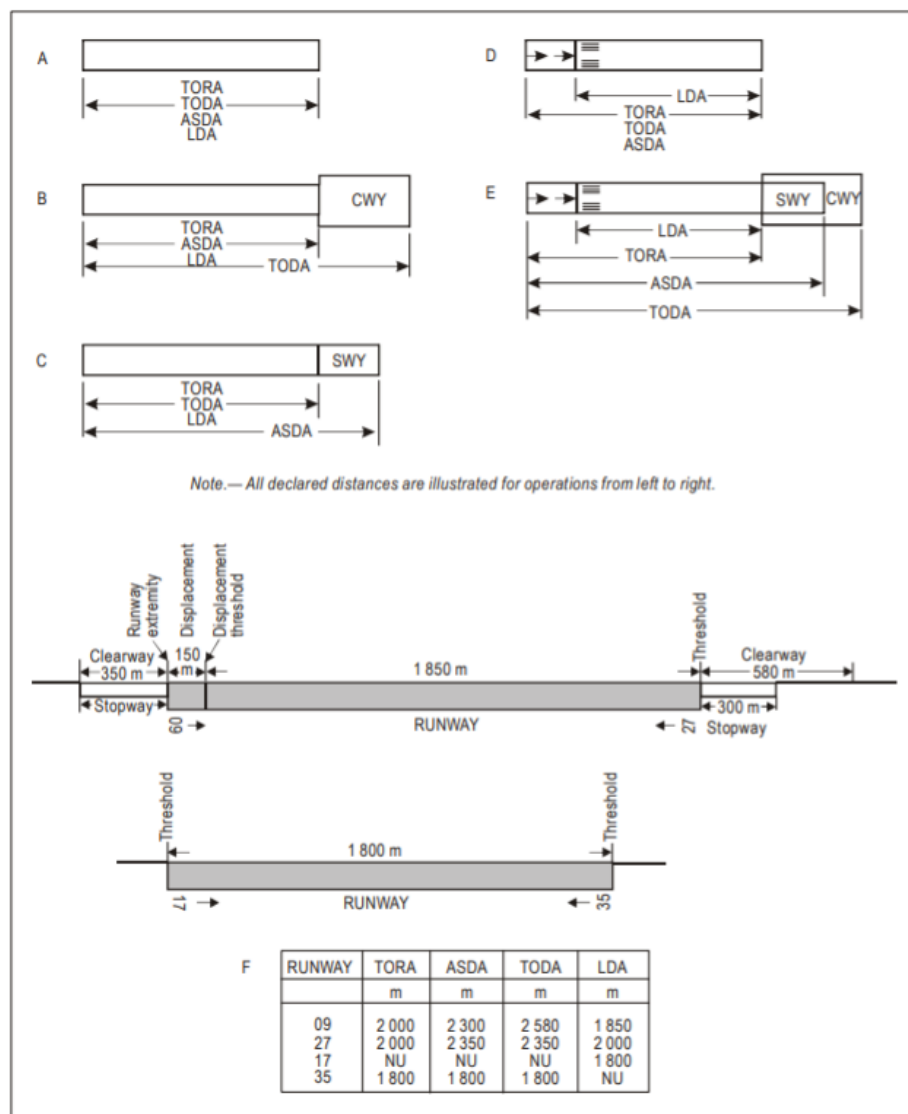

**Figure A-1. Illustration of declared distances**

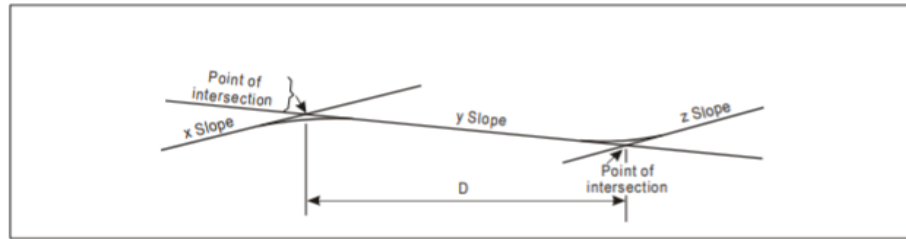

**Figure A-2: Profile on Center Line of Runway**

## 5. Runway Surface Evenness

- 5.1 In adopting tolerances for runway surface irregularities, the following standard of construction is achievable for short distances of 3 m and conforms to good engineering practice. Except across the crown of a camber or across drainage channels, the finished surface of the wearing course is to be of such regularity that, when tested with a 3 m straightedge placed anywhere in any direction on the surface, there is no deviation greater than 3 mm between the bottom of the straight-edge and the surface of the pavement anywhere along the straight edge.
- 5.2 Caution shall also be exercised when inserting runway lights or drainage grilles in runway surfaces to ensure that adequate smoothness of the surface is maintained.
- 5.3 The operation of aircraft and differential settlement of surface foundations will eventually lead to increases in surface irregularities. Small deviations in the above tolerances will not seriously hamper aircraft operations. In general, isolated irregularities of the order of 2.5 cm to 3 cm over a 45 m distance are tolerable. Although maximum acceptable variations vary with the type and speed of an aircraft, the limits of acceptable surface irregularities can be estimated to a reasonable extent. The following table describes the maximum and temporarily acceptable limits:
  - (a) Where the maximum limits are irregularities exceed the heights defined by the acceptable limit curve but are less than the heights defined by the tolerable limit curve, at the specified minimum acceptable length, herein noted by the tolerable region, then maintenance action should be planned. The runway may remain in service. This region is the start of possible passenger and pilot discomfort;
  - (b) where the surface irregularities exceed the heights defined by the tolerable limit curve, but are less than the heights defined by the excessive limit

curve, at the specified minimum acceptable length, herein noted by the excessive region, then maintenance corrective action is mandatory to restore the condition to the acceptable region. The runway may remain in service but be repaired within a reasonable period. This region could lead to the risk of possible aircraft structural damage due to a single event or fatigue failure over time; and where the surface irregularities exceed the heights defined by the excessive limit curve, at the specified minimum acceptable length, herein noted by the unacceptable region, then the area of the runway where the roughness has been identified warrants closure. Repairs must be made to restore the condition to within the acceptable limit region and the aircraft operators may be advised accordingly. This region runs the extreme risk of a structural failure and must be addressed immediately.

Surface irregularity	Length of irregularity (m)								
	3	6	9	12	15	20	30	45	60
Acceptable surface irregularity height (cm)	2.9	3.8	4.5	5	5.4	5.9	6.5	8.5	10
Tolerable surface irregularity height (cm)	3.9	5.5	6.8	7.8	8.6	9.6	11	13.6	16
Excessive surface irregularity (cm)	5.8	7.6	9.1	10	10.8	11.9	13.9	17	20

Note: that “surface irregularity” is defined herein to mean isolated surface elevation deviations that do not lie along a uniform slope through any given section of a runway. For the purposes of this concern, a “section of a runway” is defined herein to mean a segment of a runway throughout which a continuing general uphill, downhill or flat slope is prevalent. The length of this section is generally between 30 and 60 meters, and can be greater, depending on the longitudinal profile and the condition of the pavement. This section is generally between 30 and 60 meters, and can be greater, depending on the longitudinal profile and the condition of the pavement.

5.4 Figure A-3 illustrates a comparison of the surface roughness criteria with those developed by the United States Federal Aviation Administration. Further guidance regarding temporary slopes for overlay works on operational runways can be found in the *Aerodrome Design Manual, Part 3 — Pavements* (Doc 9157).

5.5 Deformation of the runway with time may also increase the possibility of the formation of water pools. Pools and shallow as approximately 3 mm in depth, particularly where they are located where they are likely to be encountered at high speed by landing aeroplanes, can induce aquaplaning, which can then be sustained on a wet runway by a smaller shallow depth of water. Improved guidance regarding the significant length and depth of pools relative to aquaplaning is the subject of further research. It is, of course especially necessary to prevent pools from forming whenever there is possibility that they might become frozen.

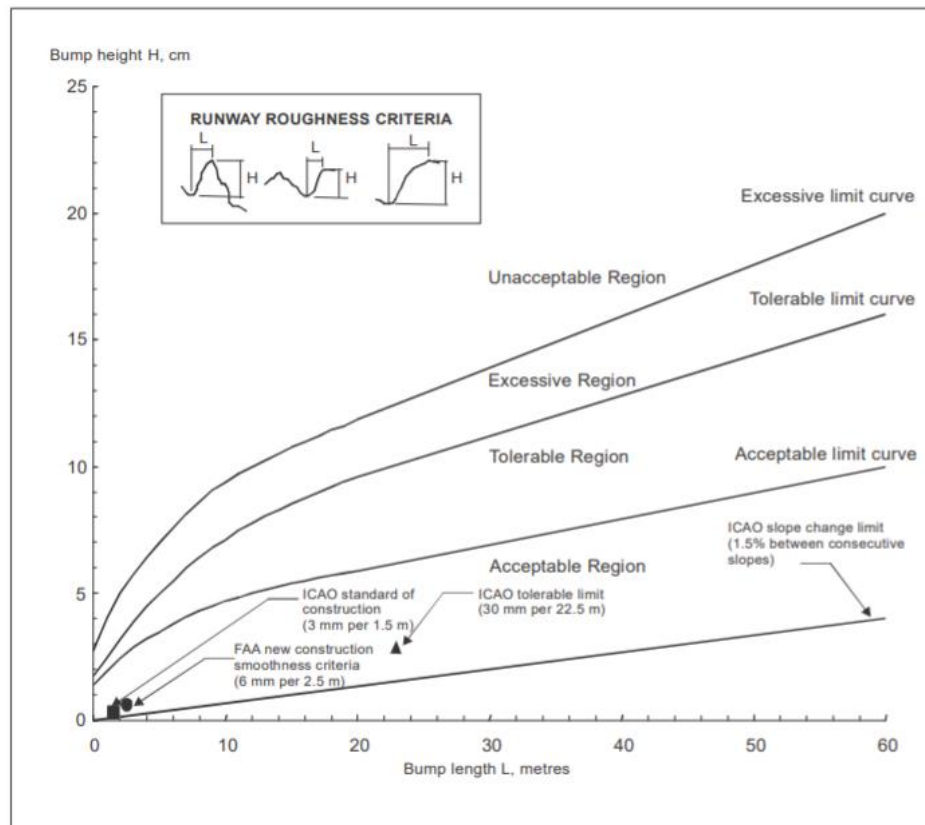

**Figure A-3. Comparison of Roughness Criteria**

Note: These criteria address single event roughness, not long wavelength harmonic effects nor the effect of repetitive surface undulations.

## Applicable until 3 November 2024

### 6. Assessing The Surface Friction Characteristics of Snow-, Slush-, Ice- And Frost-Covered Paved Surfaces

- 6.1 There is an operational need for reliable and uniform information concerning the surface condition of contaminated runways. Contaminant type, distribution and for loose contaminants, depth are assessed for each third of the runway. An indication of surface friction characteristics is helpful in conducting runway condition assessment. It can be obtained by friction measuring devices; however, there is no international consensus on the ability to correlate the results obtained by such equipment directly with aircraft performance. However, for contaminants such as slush, wet snow and wet ice, contaminant drag on the equipment's measuring wheel, amongst other factors, may cause readings obtained in these conditions to be unreliable.
- 6.2 Any friction measuring device intended predict aircraft braking performance according to an agreed local or national procedure should be shown to correlate such performance in a manner acceptable to the State. Information on the practice of one State providing correlation directly with aircraft braking performance can be found in Appendix A of *Assessment, Measurement and Reporting of Runway Surface Conditions* (ICAO Cir 329).
- 6.3 The friction conditions of a runway can be assessed in descriptive terms of "estimated surface friction". The estimated surface friction is categorized as good, medium to good, medium, medium to poor, and poor, and promulgated in PANS-AIM (Doc 10066), Appendix 4, "SNOWTAM format" as well as in PANS-ATM, Chapter 12, 12.3, "ATC phraseologies".
- 6.4 The table below with associated descriptive terms was developed from friction data collected only in compacted snow and ice and should not therefore be taken to be absolute values applicable in all conditions. Where the surface is affected by snow or ice and the estimated surface friction is reported as "good", pilots should not expect to find conditions as good as on a clean dry runway (where the available friction may well be greater than that needed in any case). The value "good" is a comparative value and is intended to mean that aeroplanes should not experience directional control or braking difficulties, especially when landing. The figures in the "Measured Coefficient  $\mu$ " column is given as an indication. At each aerodrome a specific table can be developed according to the measuring device used on the aerodrome and according to the standard and correlation criteria set or agreed by the State. The  $\mu$  values given will be specific to each friction measuring device as well as to the surface being measured and the speed employed.

Measurement coefficient $\mu$	Estimated surface friction	code
0.40 and above	Good	5
0.39 to 0.36	Medium to good	4
0.35 to 0.30	Medium	3
0.29 to 0.26	Medium to poor	2
0.25 and above	Poor	1

6.5 Relating braking action to friction measurements has been elusive over the years. The main reason is that the industry to date has not achieved the ability to control the total uncertainty associated with the readings from these devices. Consequently, readings from a friction measuring device should be used only as part of an overall runway condition assessment. A major difference between the decelerometer type of devices and the other types is that when using the decelerometer type the operator is an integrated part of the measuring process. In addition to carrying out the measurement, the operator can feel the behaviour of the vehicle where the decelerometer is installed and by that feel the deceleration process. This gives additional information in the total assessment process.

6.6 It has been found necessary to provide assessed surface condition information, including estimated surface friction, for each third of a runway. The thirds are called A, B and C. For the purpose of reporting information to aeronautical service units, section A is always the section associated with the lower runway designation number. When giving landing information to a pilot before landing, the sections are however referred to as first, second or third part of the runway. The first part always means the first third of the runway as seen in the direction of landing. Assessments are made along two lines parallel to the runway, i.e., along a line on each side of the centre line approximately 3 m, or that distance from the centre line at which most operations take place. The objective of the assessment is to determine the type, depth and coverage of the contaminants and their effect on estimated surface friction, given the prevailing weather conditions for sections A, B and C. In cases where a continuous friction measuring device is used, the mean values are obtained from the friction values recorded for each section. In cases where a spot measuring friction measuring device is used as part of the total assessment of estimated surface friction, each third of the runway should have a minimum of three tests carried out on it where achievable. Information collected and assessed on the state of pavement surface is disseminated using forms prepared by the State for SNOWTAM and NOTAM (see the Airport Services Manual (Doc 9137) Part 2).

- 6.7 The *Airport Services Manual* (Doc 9137), Part 2 provides guidance on the uniform use of test equipment and other information on removal of surface contamination and improvement of friction conditions.

Applicable 4 November 2024

## **6. Runway condition report for reporting runway surface condition**

- 6.1 On a global level, movement areas are exposed to a multitude of climatic conditions and consequently a significant difference in the condition to be reported. The runway condition report (RCR) describes a basic methodology applicable for all these climatic variations and is structured in such a way that States can adjust them to the climatic conditions applicable for that State or region.
- 6.2 The concept of the RCR is premised on:
- (a) an agreed set of criteria used in a consistent manner for runway surface condition assessment, aeroplane (performance) certification and operational performance calculation;
  - (b) a unique runway condition code (RWYCC) linking the agreed set of criteria with the aircraft landing and takeoff performance table, and related to the braking action experienced and eventually reported by flight crews;
  - (c) reporting of contaminant type and depth that is relevant to take-off performance;
  - (d) a standardized common terminology and phraseology for the description of runway surface conditions that can be used by aerodrome operator inspection personnel, air traffic controllers, aircraft operators and flight crew; and
  - (e) globally-harmonized procedures for the establishment of the RWYCC with a built-in flexibility to allow for local variations to match the specific weather, infrastructure and other particular conditions.
- 6.3 These harmonized procedures are reflected in a runway condition assessment matrix (RCAM) which correlates the RWYCC, the agreed set of criteria and the aircraft braking action which the flight crew should expect for each value of the RWYCC.
- 6.4 Procedures which relate to the use of the RCAM are provided in the PANS-Aerodromes (Doc 9981).
- 6.5 It is recognized that information provided by the aerodrome's personnel assessing and reporting runway surface condition is crucial to the effectiveness of the runway

condition report. A misreported runway condition alone should not lead to an accident or incident. Operational margins should cover for a reasonable error in the assessment, including unreported changes in the runway condition. But a misreported runway condition can mean that the margins are no longer available to cover for other operational variance (such as unexpected tailwind, high and fast approach above threshold or long flare).

- 6.6 This is further amplified by the need for providing the assessed information in the proper format for dissemination, which requires insight into the limitations set by the syntax for dissemination. This in turn restricts the wording of plain text remarks that can be provided.
- 6.7 It is important to follow standard procedures when providing assessed information on the runway surface conditions to ensure that safety is not compromised when aeroplanes use wet or contaminated runways. Personnel should be trained in the relevant fields of competence and their competence verified in a manner required by the State to ensure confidence in their assessments.
- 6.8 The training syllabus may include initial and periodic recurrent training in the following areas:
  - (a) aerodrome familiarization, including aerodrome markings, signs and lighting;
  - (b) aerodrome procedures as described in the aerodrome manual;
  - (c) aerodrome emergency plan;
  - (d) Notice to Airmen (NOTAM) initiation procedures;
  - (e) completion of/initiation procedures for RCR;
  - (f) aerodrome driving rules;
  - (g) air traffic control procedures on the movement area;
  - (h) Radiotelephone operating procedures;
  - (i) phraseology used in aerodrome control, including the ICAO spelling alphabet;
  - (j) aerodrome inspection procedures and techniques;
  - (k) type of runway contaminants and reporting;
  - (l) assessment and reporting of runway surface friction characteristics;
  - (m) use of runway friction measurement device;
  - (n) calibration and maintenance of runway friction measurement device;
  - (o) awareness of uncertainties related to l) and m); and
  - (p) low visibility procedures.

## **7. Determination of surface friction characteristics for construction and maintenance purposes**

*Applicable until 4 November 2024*

*Note: The guidance in this section involves the functional measurement of friction-related aspects related to runway construction and maintenance. Excluded from this section is the operational, as opposed to functional, measurement of friction for contaminated runways. However, the devices used for functional measurement could also be used for operational measurement, but in the latter case, the figures given in Airport Services Manual (Doc 9137), Part 2, Table 3-1 are not relevant.*

- 7.1 The surface friction characteristics of a paved runway should be:
  - (a) assessed to verify the surface friction characteristics of new or resurfaced paved runways (Regulation (4)); and
  - (b) assessed periodically in order to determine the slipperiness of paved runways (Part XVII, Regulation).
- 7.2 The condition of a runway pavement is generally assessed under dry conditions using a self-wetting continuous friction measuring device. Evaluation tests of runway surface friction characteristics are made on clean surfaces of the runway when first constructed or after resurfacing.
- 7.3 Friction tests of existing surface conditions are taken periodically in order to avoid falling below the minimum friction level specified by the State. When the friction of any portion of a runway is found to be below this value, then such information is promulgated in a NOTAM specifying which portion of the runway is below the minimum friction level and its location on the runway. A corrective maintenance action must be initiated without delay. Friction measurements are taken at time intervals that will ensure the identification of runways in need of maintenance or of special surface treatment before their condition becomes serious. The time intervals and mean frequency of measurements depend on factors such as: aircraft type and frequency of usage, climatic conditions, pavement type, and pavement service and maintenance requirements.
- 7.4 Friction measurements of existing, new or resurfaced runways are made with a continuous friction measuring device provided with a smooth tread tire. The device should use self-wetting features to allow measurements of the surface friction characteristics to be made at a water depth of 1 mm.
- 7.5 When it is suspected that the surface friction characteristics of a runway may be reduced because of poor drainage, owing to inadequate slopes or depressions, then an additional measurement is made, but this time under natural conditions representative of a local rain. This measurement differs from the previous one in that water depths in the poorly cleared areas are normally greater in a local rain condition. The measurement results are thus more apt to identify problem areas having low friction values that could induce aquaplaning than

the previous test. Where circumstances do not permit measurements to be conducted during natural conditions representative of a rain, then this condition may be simulated. (See section 8.)

- 7.6 When conducting friction tests using a self-wetting continuous friction measuring device, it is important to note that, unlike compacted snow and ice conditions, in which there is very limited variation of the friction coefficient with speed, a wet runway produces a drop in friction with an increase in speed. However, as the speed increases, the rate at which the friction is reduced becomes less. Among the factors affecting the friction coefficient between the tire and the runway surface, texture is particularly important. Where the runway has a good macro-texture allowing the water to escape beneath the tire, then the friction value will be less affected by speed. Conversely, a low macro-texture surface will produce a larger drop in friction with increase in speed.
- 7.7 This regulation, requires States to specify a minimum friction level below which corrective maintenance action should be taken. As criteria for surface friction characteristics of new or resurfaced runway surfaces and its maintenance planning, the State can establish a maintenance planning level below which appropriate corrective maintenance action should be initiated to improve the friction. The Airport Services Manual (Doc 9137), Part 2, provides guidance on establishing maintenance planning and minimum friction levels for runway surfaces in use.

## **8. Drainage Characteristics of The Movement Area and Adjacent Areas**

### **8.1 General**

8.1.1 Rapid drainage of surface water is a primary safety consideration in the design, construction and maintenance of the movement area and adjacent areas. The objective is to minimize water depth on the surface by draining water off the runway in the shortest path possible and particularly out of the area of the wheel path. There are two distinct drainage processes taking place:

- (a) natural drainage of the surface water from the top of the pavement surface until it reaches the final recipient such as rivers or other water bodies; and
- (b) dynamic drainage of the surface water trapped under a moving tire until it reaches outside the tire-to-ground contact area.

8.1.2 Both processes can be controlled through:

- (a) design;
- (b) construction; and
- (c) maintenance of the pavements in order to prevent accumulation of water on the pavement surface.

## **8.2 Design of Pavement**

- 8.2.1 Surface drainage is a basic requirement and serves to minimize water depth on the surface. The objective is to drain water off the runway in the shortest path. Adequate surface drainage is provided primarily by an appropriately sloped surface (in both the longitudinal and transverse directions). The resulting combined longitudinal and transverse slope is the path for the drainage run-off. This path can be shortened by adding transverse grooves.
- 8.2.2 Dynamic drainage is achieved through built-in texture in the pavement surface. The rolling tire builds up water pressure and squeezes the water out the escape channels provided by the texture. The dynamic drainage of the tire-to-ground contact area may be improved by adding transverse grooves provided that they are subject to rigorous maintenance.

## **8.3 Construction of Pavement**

- 8.3.1 Through construction, the drainage characteristics of the surface are built into the pavement. These surface characteristics are:
- (a) slopes;
  - (b) texture:
    - (1) macrotexture;
    - (2) macrotexture;
- 8.3.2 Slopes for the various parts of the movement area and adjacent parts are described in Part V and figures are given as per cent. Further guidance is given in the Aerodrome Design Manual (Doc 9157), Part 1, Chapter 5.
- 8.3.3 Texture in the literature is described as macrotexture or macrotexture. These terms are understood differently in various parts of the aviation industry.
- 8.3.4 Macrotexture is the texture of the individual stones and is hardly detectable by the eye. Macrotexture is considered a primary component in skid resistance at slow speeds. On a wet surface at higher speeds a water film may prevent direct contact between the surface asperities and the tire due to insufficient drainage from the tire-to-ground contact area.
- 8.3.5 Macrotexture is a built-in quality of the pavement surface. By specifying crushed material that will withstand polishing macrotexture, drainage of thin water films is ensured for a longer period of time. Resistance against polishing is expressed in terms of the Polished Stone Values (PSV) which is in principle a value obtained from a friction measurement in accordance with international standards. These standards define the PSV minima that will enable a material with a good microtexture to be selected.

- 8.3.6 A major problem with macrotexture is that it can change within short time periods without being easily detected. A typical example of this is the accumulation of rubber deposits in the touchdown area which will largely mask microtexture without necessarily reducing macrotexture.
- 8.3.7 Macrotexture is the texture among the individual stones. This scale of texture may be judged approximately by the eye. Macrotexture is primarily created by the size of aggregate used or by surface treatment of the pavement and is the major factor influencing drainage capacity at high speeds. Materials shall be selected so as to achieve good macrotexture.
- 8.3.8 The primary purpose of grooving a runway surface is to enhance surface drainage. Natural drainage can be slowed down by surface texture, but grooving can speed up the drainage by providing a shorter drainage path and increasing the drainage rate.
- 8.3.9 For measurement of macrotexture, simple methods such as the “sand and grease patch” methods described in the Airport Services Manual (Doc 9137), Part 2 were developed. These methods were used for the early research on which current airworthiness requirements are based, which refer to a classification categorizing macrotexture from A to E. This classification was developed, using sand or grease patch measuring techniques, and issued in 1971 by the Engineering Sciences Data Unit (ESDU).

*Runway classification based on texture information from ESDU 71026:*

<i>Classification</i>	<i>Texture depths (mm)</i>
A	0.10 – 0.14
B	0.15 – 0.24
C	0.25 – 0.50
D	0.51 – 1.00
E	1.01 – 2.54

- 8.3.10 Using this classification, the threshold value between microtexture and macrotexture is 0.1 mm mean texture depth (MTD). Related to this scale, the normal wet runway aircraft performance is based upon texture giving drainage and friction qualities midway between classification B and C (0.25 mm). Improved drainage through better texture might qualify for a better aircraft performance class. However, such credit must be in accordance with aeroplane manufacturers’ documentation and agreed by the State. Presently credit is given to grooved or

porous friction course runways following design, construction and maintenance criteria acceptable to the State. The harmonized certification standards of some States refer to texture giving drainage and friction qualities midway between classification D and E (1.0 mm).

- 8.3.11 For construction, design and maintenance, States use various international standards. Currently ISO 13473-1: Characterization of pavement texture by use of surface profiles — Part 1: Determination of Mean Profile Depth links the volumetric measuring technique with non-contact profile measuring techniques giving comparable texture values. These standards describe the threshold value between microtexture and macrotexture as 0.5 mm. The volumetric method has a validity range from 0.25 to 5 mm MTD. The profilometry method has a validity range from 0 to 5 mm mean profile depth (MPD). The values of MPD and MTD differ due to the finite size of the glass spheres used in the volumetric technique and because the MPD is derived from a two-dimensional profile rather than a three-dimensional surface. Therefore, a transformation equation must be established for the measuring equipment used to relate MPD to MTD.
- 8.3.12 The ESDU scale groups runway surfaces based on macrotexture from A through E, where E represents the surface with best dynamic drainage capacity. The ESDU scale thus reflects the dynamic drainage characteristics of the pavement. Grooving any of these surfaces enhances the dynamic drainage capacity. The resulting drainage capacity of the surface is thus a function of the texture (A through E) and grooving. The contribution from grooving is a function of the size of the grooves and the spacing between the grooves. Aerodromes exposed to heavy or torrential rainfall must ensure that the pavement and adjacent areas have drainage capability to withstand these rainfalls or put limitations on the use of the pavements under such extreme situations. These airports shall seek to have the maximum allowable slopes and the use of aggregates providing good drainage characteristics. They shall also consider grooved pavements in the E classification to ensure that safety is not impaired.

#### **8.4 Maintenance of Drainage Characteristics of Pavement**

- 8.4.1 Macrotexture does not change within a short timespan but accumulation of rubber can fill up the texture and as such reduce the drainage capacity, which can result in impaired safety. Furthermore, the runway structure may change over time and give unevenness which results in ponding after rainfall. Guidance on rubber removal and unevenness can be found in the Airport Services Manual (Doc 9137), Part 2. Guidance on methods for improving surface texture can be found in the Aerodrome Design Manual (Doc 9157), Part 3.
- 8.4.2 When grooving's are used, the condition of the grooves shall be regularly inspected to ensure that no deterioration has occurred and that the grooves are in good

condition. Guidance on maintenance of pavements is available in the Airport Services Manual (Doc 9137), Pavement Surface Conditions and Part 9 — Airport Maintenance Practices and the Aerodrome Design Manual (Doc 9157), Part 2.

8.4.3 The pavement may be shot blasted in order to enhance the pavement macrotexture.

## **9. Strips**

### **9.1 Shoulders**

9.1.1 The shoulder of a runway or stopway shall be prepared or constructed so as to minimize any hazard to an aeroplane running off the runway or stopway. Some guidance is given in the following paragraphs on certain special problems which may arise, and on the further question of measures to avoid the ingestion of loose stones or other objects by turbine engines.

9.1.2 In some cases, the bearing strength of the natural ground in the strip may be sufficient, without special preparation, to meet the requirements for shoulders. Where special preparation is necessary, the method used will depend on local soil conditions and the mass of the aeroplanes the runway is intended to serve. Soil tests will help in determining the best method of improvement (e.g. drainage, stabilization, surfacing, light paving).

9.1.3 Attention shall also be paid when designing shoulders to prevent the ingestion of stones or other objects by turbine engines. Similar considerations apply here to those which are discussed for the margins of taxiways in the Aerodrome (Doc 9157) Design Manual, Part 2, both as to the special measures which may be necessary and as to the distance over which such special measures, where required, shall be taken.

9.1.4 Where shoulders have been treated specially, either to provide the required bearing strength or to prevent the presence of stones or debris, difficulties may arise because of a lack of visual contrast between the runway surface and that of the adjacent strip. This difficulty can be overcome either by providing a good visual contrast in the surfacing of the runway or strip, or by providing a runway side stripe marking.

### **9.2 Objects on strips**

Within the general area of the strip adjacent to the runway, measures shall be taken to prevent an aeroplane's wheel, when sinking into the ground, from striking a hard-vertical face. Special problems may arise for runway light fittings or other objects mounted in the strip or at the intersection with a taxiway or another runway. In the case of construction, such as runways or taxiways, where the surface must also be flush with the strip surface, a vertical face can be eliminated by chamfering from the top of the construction to not less than 30 cm below the strip surface level.

Other objects, the functions of which do not require them to be at surface level, shall be buried to a depth of not less than 30 cm.

### 9.3 Grading of A Strip for Precision Approach Runways

Part X, 115(7) prescribes that the portion of a strip of an instrument runway within at least 75 m from the center line shall be graded where the code number is 3 or 4. For a precision approach runway, it may be desirable to adopt a greater width where the code number is 3 or 4. Figure B-4 shows the shape and dimensions of a wider strip that may be considered for such a runway. This strip has been designed using information on aircraft running off runways. The portion to be graded extends to a distance of 105 m from the center line, except that the distance is gradually reduced to 70 m from the centre line at both ends of the strip, for a length of 140 m from the runway end.

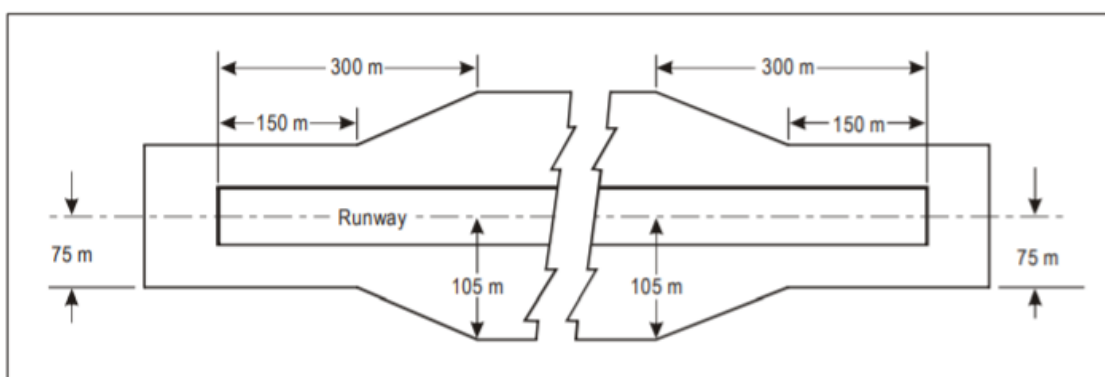

**Figure B-4. Graded Portion of a Strip Including A Precision Approach Runway Where The Code Number Is 3 or 4**

## 10. Runway End Safety Areas

**10.1** Where a runway end safety area is provided in accordance with Part X of these regulations, consideration shall be given to providing an area long enough to contain overruns and undershoots resulting from a reasonably probable combination of adverse operational factors. On a precision approach runway, the ILS localizer is normally the first upstanding obstacle, and the runway end safety area shall extend up to this facility. In other circumstances, the first upstanding obstacle may be a road, a railroad or other constructed or natural feature. The provision of a runway end safety area shall take such obstacles into consideration.

**10.2** Where provision of a runway end safety area will be particularly prohibitive to implement, consideration will have to be given to reducing some of the declared distances of the runway for the provision of a runway end safety area and installation of an arresting system.

- 10.3 Research programmes, as well as evaluation of actual aircraft overruns into arresting systems, have demonstrated that the performance of some arresting systems can be predictable and effective in arresting aircraft overruns.
- 10.4 Demonstrated performance of an arresting system can be achieved by a validated design method, which can predict the performance of the system. The design and performance shall be based on the type of aircraft anticipated to use the associated runway that imposes the greatest demand upon the arresting system.
- 10.5 The design of an arresting system must consider multiple aircraft parameters, including but not limited to, allowable aircraft gear loads, gear configuration, tire contact pressure, aircraft center of gravity and aircraft speed. Accommodating undershoots must also be addressed. Additionally, the design must allow the safe operation of fully loaded rescue and fire fighting vehicles, including their ingress and egress.
- 10.6 The information relating to the provision of a runway end safety area and the presence of an arresting system shall be published in the AIP.
- 10.7 Additional information is contained in the Aerodrome Design Manual (Doc 9157), Part 1.

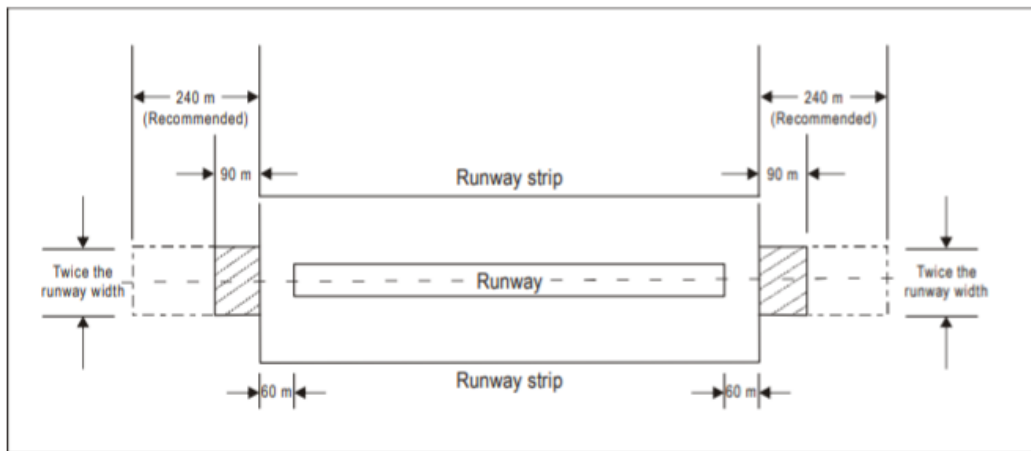

**Figure B-5 Runway End Safety Area for A Runway Where the Code Number Is 3 Or 4**

## 11. Location of Threshold

### 11.1 General

- 11.1.1 The threshold is normally located at the extremity of a runway, where there are no obstacles penetrating above the approach surface. In some cases, however, due to local conditions it may be desirable to displace the threshold permanently (see

below). When studying the location of a threshold, consideration shall also be given to the height of the ILS reference datum and/or MLS approach reference datum and the determination of the obstacle clearance limits. (Specifications concerning the height of the ILS reference datum and MLS approach reference datum are given in the applicable South Sudan Civil Aviation (Navigation Aids) Regulations.

11.1.2 In determining that no obstacle penetrate above the approach surface, account shall be taken of mobile objects (vehicles on roads, trains, etc.) at least within that portion of the approach area within 1 200 m longitudinally from the threshold and of an overall width of not less than 150 m.

## **11.2 Displaced Threshold**

11.2.1 Where an object extends above the approach surface and the object cannot be removed, consideration shall be given to displacing the threshold permanently.

11.2.2 To meet the obstacle limitation objectives of Part VI of these regulations, the threshold shall ideally be displaced down the runway for the distance necessary to provide that the approach surface is cleared of obstacles.

11.2.3 However, displacement of the threshold from the runway extremity will inevitably cause reduction of the landing distance available, and this may be of greater operational significance than penetration of the approach surface by marked and lighted obstacles. A decision to displace the threshold, and the extent of such displacement, shall therefore have regard to an optimum balance between the considerations of clear approach surfaces and adequate landing distance. In deciding this question, account will need to be taken of the types of aeroplanes which the runway is intended to serve, the limiting visibility and cloud base conditions under which the runway will be used, the position of the obstacles in relation to the threshold and extended center line and, in the case of a precision approach runway, the significance of the obstacles to the determination of the obstacle clearance limit.

11.2.4 Notwithstanding the consideration of landing distance available, the selected position for the threshold shall not be such that the obstacle-free surface to the threshold is steeper than 3.3 per cent where the code number is 4 or steeper than 5 per cent where the code number is 3.

11.2.5 In the event of a threshold being located according to the criteria for obstacle-free surfaces in the preceding paragraph, the obstacle marking requirements of Part VIII of these regulations shall continue to be met in relation to the displaced threshold.

11.2.6 Depending on the length of the displacement, the RVR at the threshold could differ from that at the beginning of the runway for take-offs. The use of red runway edge lights with photometric intensities lower than the nominal value of 10 000 cd for white lights increases that phenomenon. The impact of a displaced threshold on take-off minima should be assessed by the appropriate authority.

11.2.7 Provisions in this regulation, regarding marking and lighting of displaced thresholds and some operational recommendations can be found in Regulations 85(8), 85(9), 113, 119, 121(3), 121(7) and 123(7).

## **12. Approach Lighting Systems**

### **12.1 Types and Characteristics**

12.1.1 The specifications in this volume provide for the basic characteristics for simple and precision approach lighting systems. For certain aspects of these systems, some latitude is permitted, for example, in the spacing between centre line lights and crossbars. The approach lighting patterns that have been generally adopted are shown in Figures B-6 and B-7. A diagram of the inner 300 m of the precision approach category II and III lighting system is shown in Figure 5-14.

12.1.2 The approach lighting configuration is to be provided irrespective of the location of the threshold, i.e. whether the threshold is at the extremity of the runway or displaced from the runway extremity. In both cases, the approach lighting system shall extend up to the threshold. However, in the case of a displaced threshold, inset lights are used from the runway extremity up to the threshold to obtain the specified configuration. These inset lights are designed to satisfy the structural requirements specified in Part VII, Regulation 103(1), and the photometric requirements specified in Fourth Schedule, Figure A2-1 or A2-2.

12.1.3 Flight path envelopes to be used in designing the lighting are shown in Figure B-5.

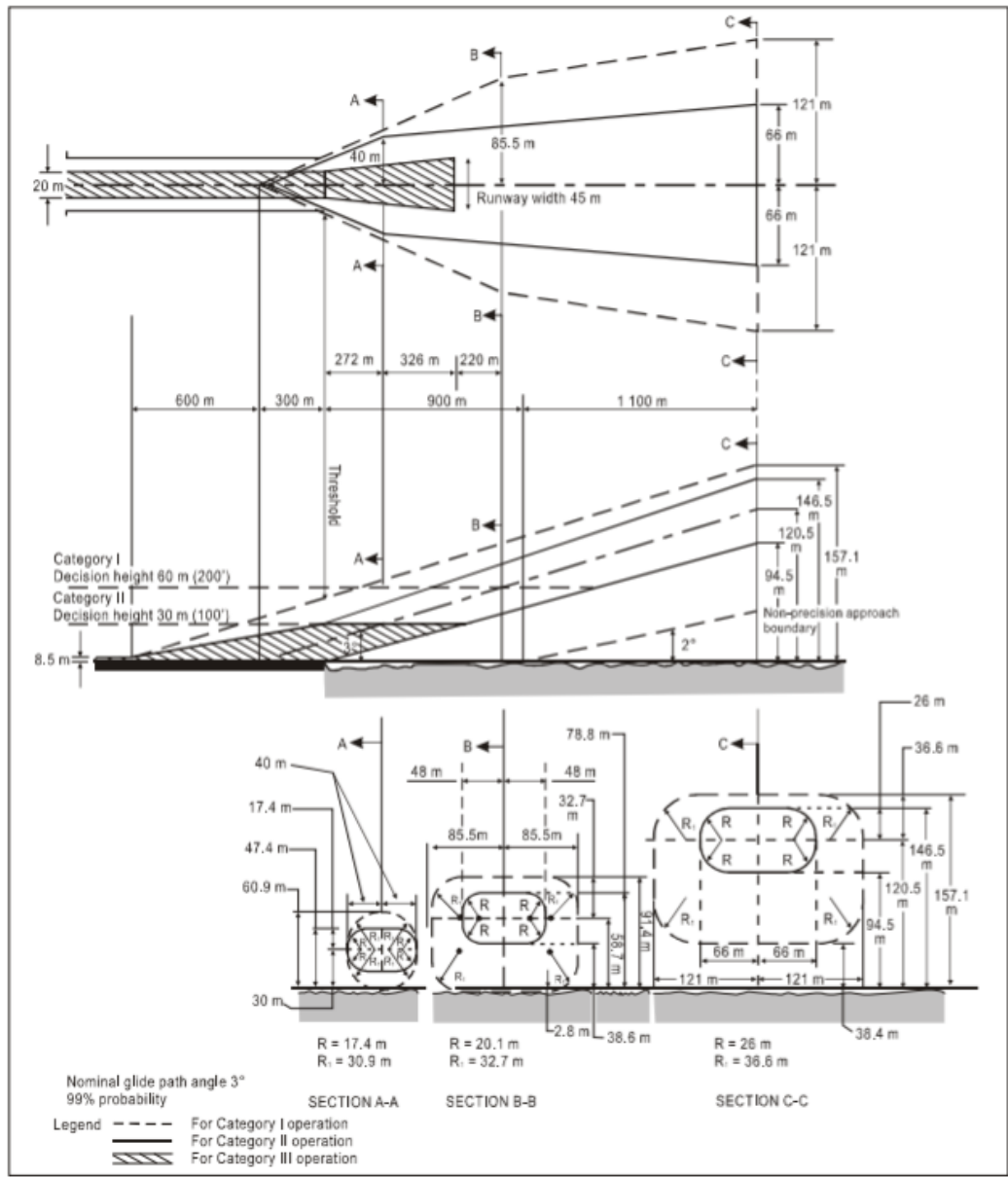
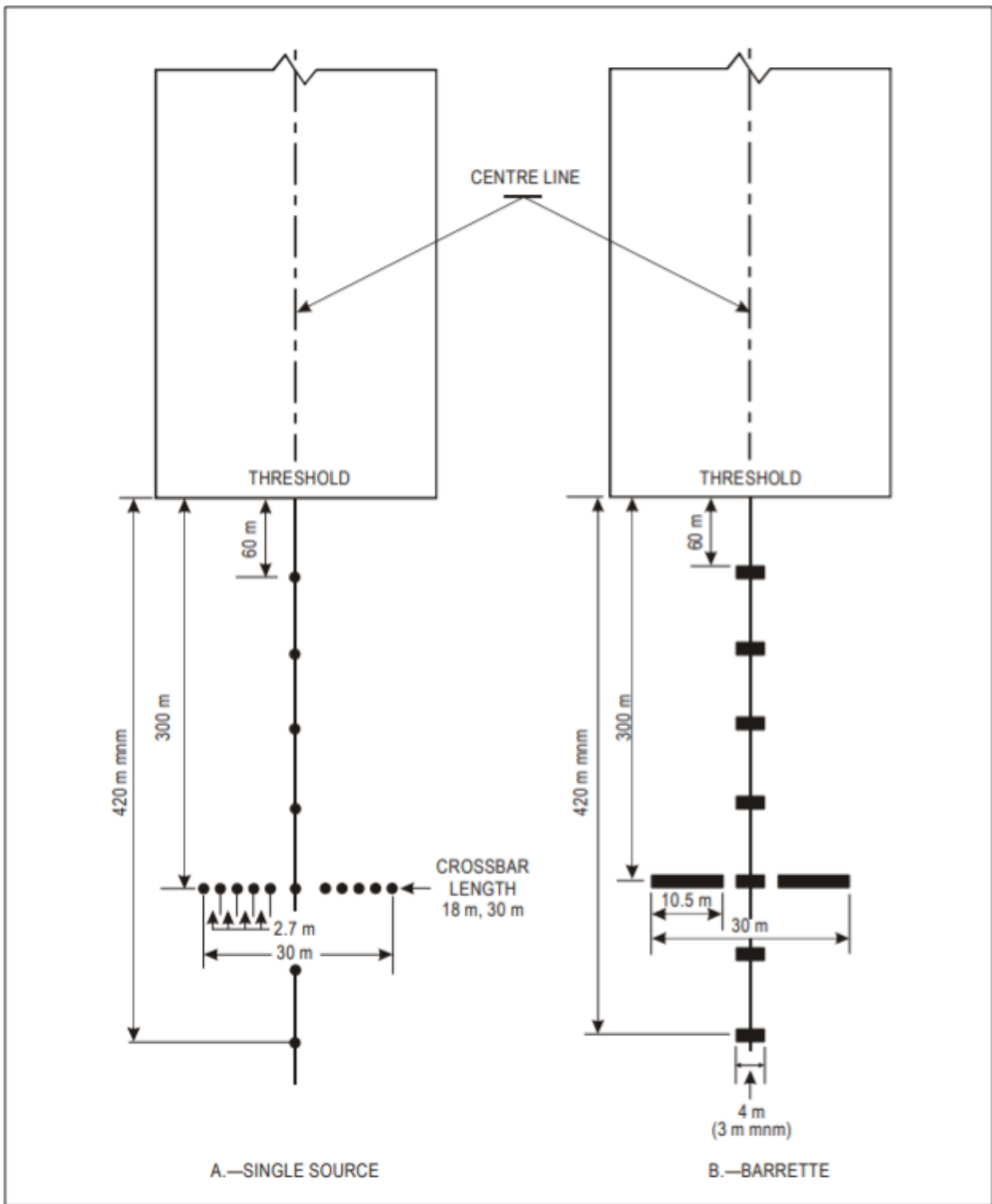

Figure A-6. Flight Path Envelop to Be Used for Lighting Design for Category I, II and III Operations



**Figure A-7. Simple Approach Lighting System**

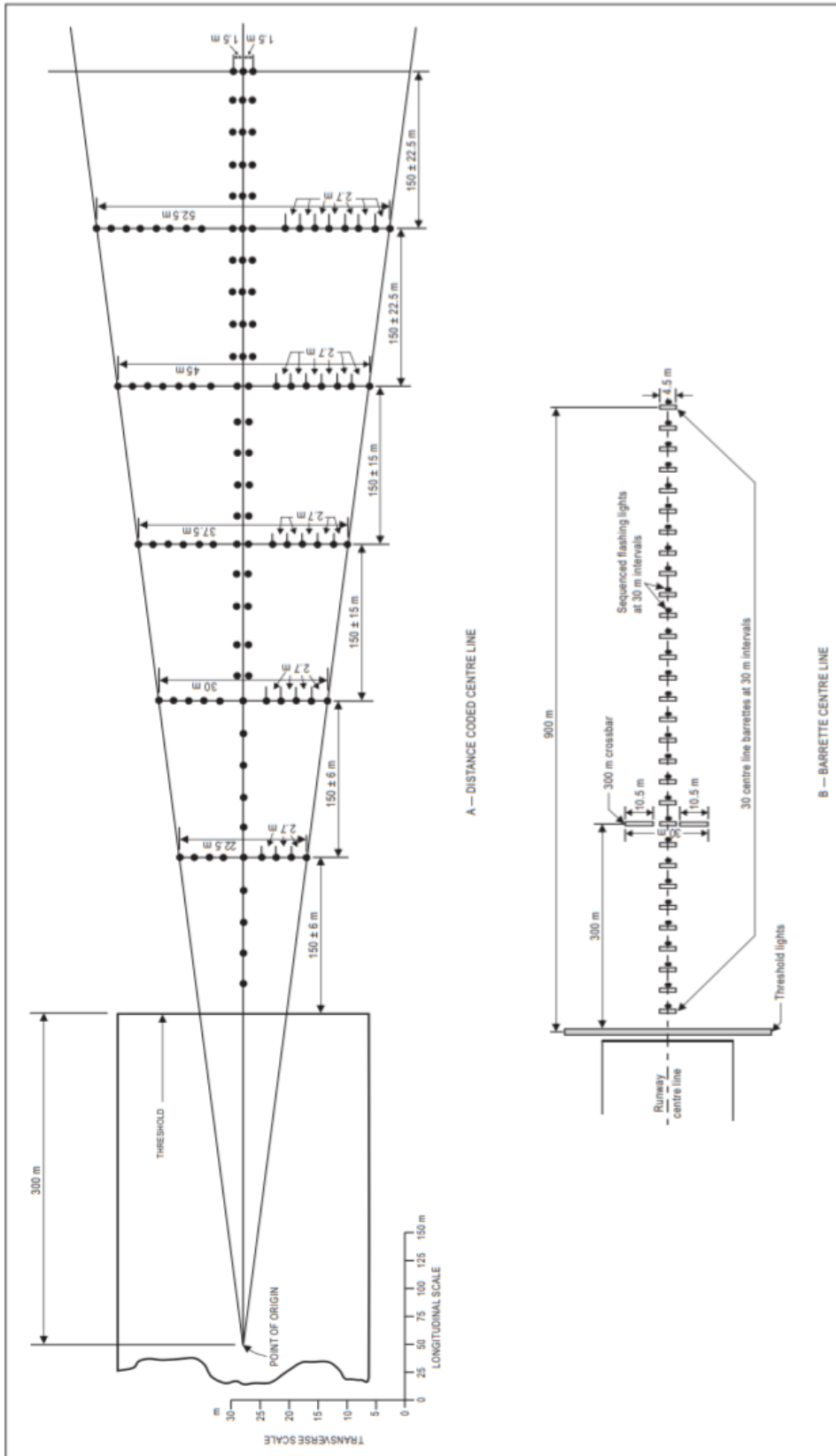

Figure B-7. Precision Approach Category 1 Lighting Systems

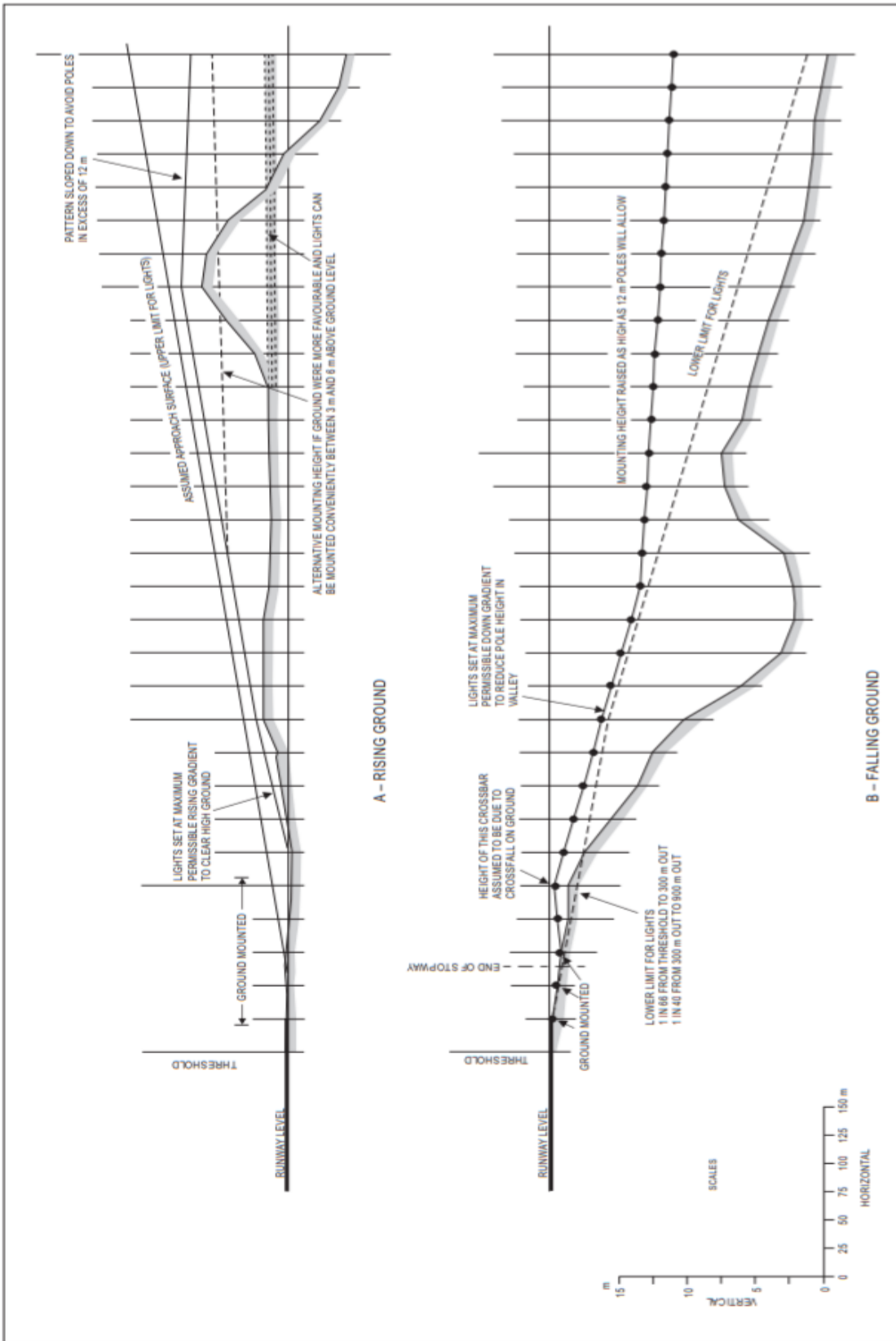

Figure B-8. Vertical Installation Tolerance

## **12.2 Installation Tolerances**

### **Horizontal**

- 12.2.1 The dimensional tolerances are shown in Figure B-7.
- 12.2.2 The center line of an approach lighting system shall be as coincident as possible with the extended center line of the runway with a maximum tolerance of  $\pm 15'$ .
- 12.2.3 The longitudinal spacing of the center line lights shall be such that one light (or group of lights) is located in the center of each crossbar, and the intervening center line lights are spaced as evenly as practicable between two crossbars or a crossbar and a threshold.
- 12.2.4 The crossbars and barrettes shall be at right angles to the center line of the approach lighting system with a tolerance of  $\pm 30'$ , where the pattern in Figure B-7 (A) is adopted or  $\pm 2^\circ$ , where Figure B-7 (B) is adopted.
- 12.2.5 When a crossbar has to be displaced from its standard position, any adjacent crossbar shall, where possible, be displaced by appropriate amounts in order to reduce the differences in the crossbar spacing.
- 12.2.6 When a crossbar in the system shown in Figure B-7 (A) is displaced from its standard position, its overall length shall be adjusted so that it remains one twentieth of the actual distance of the crossbar from the point of origin. It is not necessary, however, to adjust the standard 2.7 m spacing between the crossbar lights, but the crossbars shall be kept symmetrical about the center line of the approach lighting.

### **Vertical**

- 12.2.7 The ideal arrangement is to mount all the approach lights in the horizontal plane passing through the threshold (see Figure B-8), and this shall be the general aim as far as local conditions permit. However, buildings, trees, etc., shall not obscure the lights from the view of a pilot who is assumed to be  $1^\circ$  below the electronic glide path in the vicinity of the outer marker.
- 12.2.8 Within a stop way or clearway, and within 150 m of the end of a runway, the lights shall be mounted as near to the ground as local conditions permit in order to minimize risk of damage to aeroplanes in the event of an overrun or undershoot. Beyond the stop way and clearway, it is not so necessary for the lights to be mounted close to the ground and therefore undulations in the ground contours can be compensated for by mounting the lights on poles of appropriate height.
- 12.2.9 It is desirable that the lights be mounted so that, as far as possible, no object within a distance of 60 m on each side of the center line protrudes through the plane of the approach lighting system. Where a tall object exists within 60 m of the center line and within 1 350 m from the threshold for a precision approach lighting system, or 900 m for a simple approach lighting system, it may be advisable to install the lights so that the plane of the outer half of the pattern clears the top of the object.

- 12.2.10 In order to avoid giving a misleading impression of the plane of the ground, the lights shall not be mounted below a gradient of 1 in 66 downwards from the threshold to a point 300 m out, and below a gradient of 1 in 40 beyond the 300 m point. For a precision approach category II and III lighting system, more stringent criteria may be necessary, e.g. negative slopes not permitted within 450 m of the threshold.
- 12.2.11 Centre line. The gradients of the center line in any section (including a stop way or clearway) shall be as small as practicable, and the changes in gradients shall be as few and small as can be arranged and shall not exceed 1 in 60. Experience has shown that as one proceeds outwards from the runway, rising gradients in any section of up to 1 in 66, and falling gradients of down to 1 in 40, are acceptable.
- 12.2.12 Crossbars. The crossbar lights shall be so arranged as to lie on a straight line passing through the associated center line lights, and wherever possible this line shall be horizontal. It is permissible, however, to mount the lights on a transverse gradient not more than 1 in 80, where this enables crossbar lights within a stop way or clearway to be mounted nearer to the ground on sites where there is a cross-fall.

### **12.3 Clearance of Obstacles**

- 12.3.1 An area, hereinafter referred to as the light plane, has been established for obstacle clearance purposes, and all lights of the system are in this plane. This plane is rectangular in shape and symmetrically located about the approach lighting system's center line. It starts at the threshold and extends 60 m beyond the approach end of the system, and is 120 m wide.
- 12.3.2 No objects are permitted to exist within the boundaries of the light plane which are higher than the light plane except as designated herein. All roads and highways are considered as obstacles extending 4.8 m above the crown of the road, except aerodrome service roads where all vehicular traffic is under control of the aerodrome authorities and coordinated with the aerodrome traffic control tower. Railroads, regardless of the amount of traffic, are considered as obstacles extending 5.4 m above the top of the rails.
- 12.3.3 It is recognized that some components of electronic landing aids systems, such as reflectors, antennas, monitors, etc., must be installed above the light plane. Every effort shall be made to relocate such components outside the boundaries of the light plane. In the case of reflectors and monitors, this can be done in many instances.
- 12.3.4 Where an ILS localizer is installed within the light plane boundaries, it is recognized that the localizer, or screen where used, must extend above the light plane. In such cases the height of these structures shall be held to a minimum and they shall be located as far from the threshold as possible. In general, the rule regarding permissible heights is 15 cm for each 30 m the structure is located from the threshold. As an example, where the localizer is located 300 m from the threshold, the screen will be permitted to extend above the plane of the approach

lighting system by  $10 \times 15 = 150$  cm maximum, but preferably shall be kept as low as possible consistent with proper operation of the ILS.

12.3.5 In locating an MLS azimuth antenna, the guidance contained in the applicable South Sudan Civil Aviation (Navigation Aids) Regulations shall be followed. This material, which also provides guidance on collocating an MLS azimuth antenna with an ILS localizer antenna, suggests that the MLS azimuth antenna may be sited within the light plane boundaries where it is not possible or practical to locate it beyond the outer end of the approach lighting for the opposite direction of approach. Where the MLS azimuth antenna is located on the extended center line of the runway, it shall be as far as possible from the closest light position to the MLS azimuth antenna in the direction of the runway end. Furthermore, the MLS azimuth antenna phase center shall be at least 0.3 m above the light center of the light position closest to the MLS azimuth antenna in the direction of the runway end. (This may be relaxed to 0.15 m where the site is otherwise free of significant multipath problems.) Compliance with this requirement, which is intended to ensure that the MLS signal quality is not affected by the approach lighting system, may result in the partial obstruction of the lighting system by the MLS azimuth antenna. To ensure that the resulting obstruction does not degrade visual guidance beyond an acceptable level, the MLS azimuth antenna shall not be located closer to the runway end than 300 m and the preferred location is 25 m beyond the 300 m crossbar (this will place the antenna 5 m behind the light position 330 m from the runway end). Where an MLS azimuth antenna is so located, a central part of the 300 m crossbar of the approach lighting system will alone be partially obstructed. Nevertheless, it is important to ensure that the unobstructed lights of the crossbar remain serviceable all the time.

12.3.6 Objects existing within the boundaries of the light plane, requiring the light plane to be raised in order to meet the criteria contained herein, shall be removed, lowered or relocated where this can be accomplished more economically than raising the light plane.

12.3.7 In some instances objects may exist which cannot be removed, lowered or relocated economically. These objects may be located so close to the threshold that they cannot be cleared by the 2 per cent slope. Where such conditions exist and no alternative is possible, the 2 per cent slope may be exceeded or a “stair step” resorted to in order to keep the approach lights above the objects. Such “step” or increased gradients shall be resorted to only when it is impracticable to follow standard slope criteria, and they shall be held to the absolute minimum. Under this criterion no negative slope is permitted in the outermost portion of the system.

#### **12.4 Consideration of the Effects of Reduced Lengths**

12.4.1 The need for an adequate approach lighting system to support precision approaches where the pilot is required to acquire visual references prior to landing, cannot be stressed too strongly. The safety and regularity of such operations is dependent on this visual acquisition. The height above runway threshold at which the pilot

decides there are sufficient visual cues to continue the precision approach and land will vary, depending on the type of approach being conducted and other factors such as meteorological conditions, ground and airborne equipment, etc. The required length of approach lighting system which will support all the variations of such approaches is 900 m, and this shall always be provided whenever possible.

**12.5** However, there are some runway locations where it is impossible to provide the 900 m length of approach lighting system to support precision **approaches**.

12.5.1 In such cases, every effort shall be made to provide as much approach lighting system as possible. The appropriate authority may impose restrictions on operations to runways equipped with reduced lengths of lighting. There are many factors which determine at what height the pilot must have decided to continue the approach to land or execute a missed approach. It must be understood that the pilot does not make an instantaneous judgment upon reaching a specified height. The actual decision to continue the approach and landing sequence is an accumulative process which is only concluded at the specified height. Unless lights are available prior to reaching the decision point, the visual assessment process is impaired and the likelihood of missed approaches will increase substantially. There are many operational considerations which must be taken into account by the appropriate authorities in deciding where any restrictions are necessary to any precision approach and these are detailed in the applicable South Sudan Civil Aviation (Air Operations) Regulations.

### **13. Priority of Installation of Visual Approach Slope Indicator Systems**

**13.1** It has been found impracticable to develop guidance material that will permit a completely objective analysis to be made of which runway on an aerodrome shall receive first priority for the installation of a visual approach slope indicator system. However, factors that must be considered when making such a decision are:

- (a) frequency of use;
- (b) seriousness of the hazard;
- (c) presence of other visual and non-visual aids;
- (d) type of aeroplanes using the runway; and
- (e) frequency and type of adverse weather conditions under which the runway will be used.

**13.2** With respect to the seriousness of the hazard, the order given in the application specifications for a visual approach slope indicator system, may be used as a general guide. These may be summarized as:

- (a) inadequate visual guidance because of:
  - (i) approaches over water or featureless terrain, or absence of sufficient extraneous light in the approach area by night;
  - (ii) deceptive surrounding terrain;
- (b) serious hazard in approach;
- (c) serious hazard where aeroplanes undershoot or overrun; and
- (d) unusual turbulence.

**13.3** The presence of other visual or non-visual aids is a very important factor. Runways equipped with ILS or MLS will generally receive the lowest priority for a visual approach slope indicator system installation. It must be remembered, though, that visual approach slope indicator systems are visual approach aids in their own right and can supplement electronic aids. When serious hazards exist and/or a substantial number of aeroplanes not equipped for ILS or MLS use a runway, priority might be given to installing a visual approach slope indicator on this runway.

**13.4** Priority shall be given to runways used by turbojet aeroplanes.

#### **14. Lighting of Unserviceable Areas**

Where a temporarily unserviceable area exists, it may be marked with fixed-red lights. These lights shall mark the most potentially dangerous extremities of the area. A minimum of four such lights shall be used, except where the area is triangular in shape where a minimum of three lights may be employed. The number of lights shall be increased when the area is large or of unusual configuration. At least one light shall be installed for each 7.5 m of peripheral distance of the area. Where the lights are directional, they shall be orientated so that as far as possible their beams are aligned in the direction from which aircraft or vehicles will approach. Where aircraft or vehicles will normally approach from several directions, consideration shall be given to adding extra lights or using omnidirectional lights to show the area from these directions. Unserviceable area lights shall be frangible. Their height shall be sufficiently low to preserve clearance for propellers and for engine pods of jet aircraft.

#### **15. Rapid Exit Taxiway Indicator Lights (RETILs)**

**15.1** Rapid exit taxiway indicator lights (RETILs) comprise a set of yellow unidirectional lights installed in the runway adjacent to the center line. The lights are positioned in a 3-2-1 sequence at 100 m intervals prior to the point of tangency of the rapid exit taxiway center line. They are intended to give an indication to pilots of the location of the next available rapid exit taxiway.

**15.2** In low visibility conditions, RETILs provide useful situational awareness cues while

**15.3** allowing the pilot to concentrate on keeping the aircraft on the runway center line.

**15.4** Following a landing, runway occupancy time has a significant effect on achievable runway capacity. RETILs allow pilots to maintain a good roll-out speed until it is necessary to decelerate to an appropriate speed for the turn into a rapid exit turn-off. A roll-out speed of 60 knots until the first RETIL (three-light barrette) is reached is seen as the optimum.

#### **16. Intensity Control of Approach and Runway Lights**

**16.1** The conspicuity of a light depends on the impression received of contrast between the light and its background. Where a light is to be useful to a pilot by day when on approach, it must have an intensity of at least 2 000 or 3 000 cd, and in the case of approach lights an intensity of the order of 20 000 cd is desirable. In conditions of very bright daylight fog it may not be possible to provide lights of sufficient

intensity to be effective. On the other hand, in clear weather on a dark night, an intensity of the order of 100 cd for approach lights and 50 cd for the runway edge lights may be found suitable. Even then, owing to the closer range at which they are viewed, pilots have sometimes complained that the runway edge lights seemed unduly bright.

**16.2** In fog the amount of light scattered is high. At night this scattered light increases the brightness of the fog over the approach area and runway to the extent that little increase in the visual range of the lights can be obtained by increasing their intensity beyond 2 000 or 3 000 cd. In an endeavor to increase the range at which lights will first be sighted at night, their intensity must not be raised to an extent that a pilot might find excessively dazzling at diminished range.

**16.3** From the foregoing will be evident the importance of adjusting the intensity of the lights of an aerodrome lighting system according to the prevailing conditions, so as to obtain the best results without excessive dazzle that will disconcert the pilot. The appropriate intensity setting on any particular occasion will depend both on the conditions of background brightness and the visibility. Detailed guidance material on selecting intensity setting for different conditions is given in the Aerodrome Design Manual (Doc 9157), Part 4.

## **17. Signal Area**

A signal area need be provided only when it is intended to use visual ground signals to communicate with aircraft in flight. Such signals may be needed when the aerodrome does not have an aerodrome control tower or an aerodrome flight information service unit, or when the aerodrome is used by aeroplanes not equipped with radio. Visual ground signals may also be useful in the case of failure of two-way radio communication with aircraft. It shall be recognized, however, that the type of information which may be conveyed by visual ground signals shall normally be available in AIPs or NOTAM. The potential need for visual ground signals shall therefore be evaluated before deciding to provide a signal area.

## **18. Rescue and Firefighting Services**

### **18.1 Administration**

18.1.1 The rescue and firefighting service at an aerodrome shall be under the administrative control of the aerodrome management, which shall also be responsible for ensuring that the service provided is organized, equipped, staffed, trained and operated in such a manner as to fulfill its proper functions.

18.1.2 In drawing up the detailed plan for the conduct of search and rescue operations South Sudan Civil Aviation (Search and Rescue) regulation), the aerodrome management shall coordinate its plans with the relevant rescue coordination centers to ensure that the respective limits of their responsibilities for an aircraft accident within the vicinity of an aerodrome are clearly delineated.

18.1.3 Coordination between the rescue and firefighting service at an aerodrome and public protective agencies, such as local fire brigade, police force, coast guard and

hospitals, shall be achieved by prior agreement for assistance in dealing with an aircraft accident.

18.1.4 A grid map of the aerodrome and its immediate vicinity shall be provided for the use of the aerodrome services concerned. Information concerning topography, access roads and location of water supplies shall be indicated. This map shall be conspicuously posted in the control tower and fire station and available on the rescue and fire fighting vehicles and such other supporting vehicles required to respond to an aircraft accident or incident. Copies shall also be distributed to public protective agencies as desirable.

18.1.5 Coordinated instructions shall be drawn up detailing the responsibilities of all concerned and the action to be taken in dealing with emergencies. The appropriate authority shall ensure that such instructions are promulgated and observed.

## **18.2 Training**

The training curriculum shall include initial and recurrent instruction in at least the following areas:

- (a) airport familiarization;
- (b) aircraft familiarization;
- (c) rescue and firefighting personnel safety;
- (d) emergency communications systems on the aerodrome, including aircraft fire related alarms;
- (e) use of the fire hoses, nozzles, turrets and other appliances required for compliance with Part XVI, Regulation 263 - Regulation 272;
- (f) application of the types of extinguishing agents required for compliance with Part XVI, 9.2 Regulation 263-Regulation 272;
- (g) emergency aircraft evacuation assistance;
- (h) firefighting operations;
- (i) adaptation and use of structural rescue and fire-fighting equipment for aircraft rescue and firefighting;
- (j) dangerous goods;
- (k) familiarization with fire fighters' duties under the aerodrome emergency plan; and
- (l) protective clothing and respiratory protection.

## **18.3 Level of protection to be provided**

18.3.1 In accordance with Part XVI, 9.2 Regulation 263-Regulation 272 aerodromes shall be categorized for rescue and firefighting purposes and the level of protection provided shall be appropriate to the aerodrome category.

18.3.2 However, Part XI, Regulation 192 (1) permits a lower level of protection to be provided for a limited period where the number of movements of the aeroplanes in the highest category normally using the aerodrome is less than 700 in the busiest consecutive three months. It is important to note that the concession included in Regulation 192 (1) is applicable only where there is

a wide range of difference between the dimensions of the aeroplanes included in reaching 700 movements.

#### **18.4 Rescue Equipment for Difficult Environments**

- 18.4.1 Suitable rescue equipment and services shall be available at an aerodrome where the area to be covered by the service includes water, swampy areas or other difficult environment that cannot be fully served by conventional wheeled vehicles. This is particularly important where a significant portion of approach/departure operations takes place over these areas.
- 18.4.2 The rescue equipment shall be carried on boats or other vehicles such as helicopters and amphibious or air cushion vehicles, capable of operating in the area concerned. The vehicles shall be so located that they can be brought into action quickly to respond to the areas covered by the service.
- 18.4.3 At an aerodrome bordering the water, the boats or other vehicles shall preferably be located on the aerodrome, and convenient launching or docking sites provided. Where these vehicles are located off the aerodrome, they shall preferably be under the control of the aerodrome rescue and firefighting service or, where this is not practicable, under the control of another competent public or private organization working in close coordination with the aerodrome rescue and firefighting service (such as police, military services, harbor patrol or coast guard).
- 18.4.4 Boats or other vehicles shall have as high a speed as practicable so as to reach an accident site in minimum time. To reduce the possibility of injury during rescue operations, water jet-driven boats are preferred to water propeller driven boats unless the propellers of the latter boats are ducted. Shall the water areas to be covered by the service be frozen for a significant period of the year, the equipment shall be selected accordingly. Vehicles used in this service shall be equipped with life rafts and life preservers related to the requirements of the larger aircraft normally using the aerodrome, with two-way radio communication, and with floodlights for night operations. Where aircraft operations during periods of low visibility are expected, it may be necessary to provide guidance for the responding emergency vehicles.
- 18.4.5 The personnel designated to operate the equipment shall be adequately trained and drilled for rescue services in the appropriate environment.

#### **18.5 Facilities**

- 18.5.1 The provision of special telephone, two-way radio communication and general alarm systems for the rescue and firefighting service is desirable to ensure the dependable transmission of essential emergency and routine information. Consistent with the individual requirements of each aerodrome, these facilities serve the following purposes:

- (a) direct communication between the activating authority and the aerodrome fire station in order to ensure the prompt alerting and dispatch of rescue and fire fighting
- (b) vehicles and personnel in the event of an aircraft accident or incident;
- (c) emergency signals to ensure the immediate summoning of designated personnel not on standby duty;
- (d) as necessary, summoning essential related services on or off the aerodrome; and
- (e) maintaining communication by means of two-way radio with the rescue and fire fighting vehicles in attendance at an aircraft accident or incident.

18.5.2 The availability of ambulance and medical facilities for the removal and after-care of casualties arising from an aircraft accident shall receive the careful consideration of the aerodrome operator and shall form part of the overall emergency plan established to deal with such emergencies.

## **19. Operators of Vehicles**

**19.1** The authorities responsible for the operation of vehicles on the movement area shall ensure that the operators are properly qualified. This may include, as appropriate to the driver's function, knowledge of:

- (a) the geography of the aerodrome;
- (b) aerodrome signs, markings and lights;
- (c) radiotelephone operating procedures;
- (d) terms and phrases used in aerodrome control including the ICAO spelling alphabet;
- (e) rules of air traffic services as they relate to ground operations;
- (f) airport rules and procedures; and
- (g) specialist functions as required, for example, in rescue and firefighting.

**19.2** The operator should be able to demonstrate competency, as appropriate, in:

- (a) the operation or use of vehicle transmit/receive equipment;
- (b) understanding and complying with air traffic control and local procedures;
- (c) vehicle navigation on the aerodrome; and
- (d) special skills required for the particular function. In addition, as required for any specialist function, the operator should be the holder of a state driver's license, a state radio operator's license or other license.

**19.3** The above should be applied as is appropriate to the function to be performed by the operator, and it is not necessary that all operators be trained to the same level, for example, operators whose functions are restricted to the apron.

**19.4** Where special procedures apply for operations in low visibility conditions, it is desirable to verify an operator's knowledge of the procedures through periodic checks.

## **20. The ACN-PCN Method of Reporting Pavement Strength**

**20.1** Overload operations

20.1.1 Overloading of pavements can result either from loads too large, or from a substantially increased application rate, or both. Loads larger than the defined (design or evaluation) load shortens the design life, whilst smaller loads extend it. With the exception of massive overloading, pavements in their structural behavior are not subject to a particular limiting load above which they suddenly or catastrophically fail. Behavior is such that a pavement can sustain a definable load for an expected number of repetitions during its design life. As a result, occasional minor overloading is acceptable, when expedient, with only limited loss in pavement life expectancy and relatively small acceleration of pavement deterioration. For those operations in which magnitude of overload and/or the frequency of use do not justify a detailed analysis, the following criteria are suggested:

- (a) for flexible pavements, occasional movements by aircraft with ACN not exceeding 10 per cent above the reported PCN should not adversely affect the pavement;
- (b) for rigid or composite pavements, in which a rigid pavement layer provides a primary element of the structure, occasional movements by aircraft with ACN not exceeding 5 per cent above the reported PCN should not adversely affect the pavement;
- (c) if the pavement structure is unknown, the 5 per cent limitation should apply; and
- (d) the annual number of overload movements should not exceed approximately 5 percent of the total annual aircraft movements.

20.1.2 Such overload movements shall not normally be permitted on pavements exhibiting signs of distress or failure. Furthermore, overloading shall be avoided during any periods of thaw following frost penetration, or when the strength of the pavement or its sub-grade may be weakened by water. Where overload operations are conducted, the appropriate authority shall review the relevant pavement condition regularly and shall also review the criteria for overload operations periodically since excessive repetition of overloads can cause severe shortening of pavement life or require major rehabilitation of pavement.

## **20.2 ACNs for several aircraft types**

For convenience, several aircraft types currently in use have been evaluated on rigid and flexible pavements founded on the four sub-grade strength categories in Part V Regulation 42, and the results tabulated in the ICAO Aerodrome Design Manual (Doc 9157), Part 3.

## **20A. The ACR-PCR Method of Reporting Pavement Strength**

- (1) Overloading of pavements can result either from loads too large, or from a substantially increased application rate, or both. Loads larger than the defined (Design or evaluation) load shortens the design life, whilst smaller loads extend it.

- (2) With the exception of massive overloading, pavements in their structural Behaviour is not subject to a particular limiting load above which they suddenly or catastrophically fail. Behaviour is such that a pavement can sustain a definable load for an expected number of repetitions during its design life. As a result, occasional minor overloading is acceptable, when expedient, with only limited loss of pavement life expectancy and relatively small acceleration of pavement deterioration.
- (3) For those operations in which magnitude of overload and/or the frequency of use do not justify a detailed analysis; the following criteria are suggested:
  - (a) for flexible and rigid pavements, occasional movements by aircraft with ACR not exceeding 10 per cent above the reported PCR should not adversely affect the pavement; and
  - (b) the annual number of overload movements should not exceed approximately 5 per cent of the total annual aircraft movements, excluding light aircraft.
- (4) Such overload movements should not normally be permitted on pavement exhibiting signs of distress or failure. Furthermore, overloading should be avoided during any periods of thaw following frost penetration, or when the strength of the pavement or its subgrade could be weakened by water.
- (5) Where overload operations are conducted, the appropriate authority should review the relevant pavement condition regularly, and should also review the criteria for overload operations periodically since excessive repetition of overloads can cause severe shortening of pavement life or require major rehabilitation of pavement.
- (6) For convenience, a dedicated software is available on the ICAO website, for computing gany aircraft ACRs at any mass on rigid and flexible pavements for the four standard subgrade strength categories detailed in Regulation 70 (6) b.

## **21. Autonomous Runway Incursion Warning System (ARIWS)**

Note 1: These autonomous systems are generally quite complex in design and operation and, as such, deserve careful consideration by all levels of the industry, from the regulating authority to the end user. This guidance is offered to provide a clearer description of the system(s) and offer some suggested actions required in order to properly implement these system(s) at an aerodrome in any State.

Note 2: The Manual on the Prevention of Runway Incursion (Doc 9870) presents different approaches for the prevention of runway incursion.

### **21.1 General Description**

21.1.1 The operation of an ARIWS is based upon a surveillance system which monitors the actual situation on a runway and automatically returns this information to warning lights at the runway (take-off) thresholds and entrances. When an aircraft is departing from a runway (rolling) or arriving at a runway (short final), red warning lights at the entrances will illuminate, indicating that it is unsafe to enter or cross the runway. When an aircraft is

aligned on the runway for take-off and another aircraft or vehicle enters or crosses the runway, red warning lights will illuminate at the threshold area, indicating that it is unsafe to start the take-off roll.

- 21.1.2 In general, an ARIWS consists of an independent surveillance system (primary radar, multilateration, specialized cameras, dedicated radar, etc.) and a warning system in the form of extra airfield lighting systems connected through a processor which generates alerts independent from ATC directly to the flight crews and vehicle operators.
- 21.1.3 An ARIWS does not require circuit interleaving, secondary power supply or operational connection to other visual aid systems.
- 21.1.4 In practice, not every entrance or threshold needs to be equipped with warning lights. Each aerodrome will have to assess its needs individually depending on the characteristics of the aerodrome. There are several systems developed offering the same or similar functionality.

## **21.2 Flight Crew Actions**

- 21.2.1 It is of critical importance that flight crews understand the warning being transmitted by the ARIWS system. Warnings are provided in near real-time, directly to the flight crew because there is no time for “relay” types of communications. In other words, a conflict warning generated to ATS which must then interpret the warning, evaluate the situation and communicate to the aircraft in question, would result in several seconds being taken up where each second is critical in the ability to stop the aircraft safely and prevent a potential collision. Pilots are presented with a globally consistent signal which means “STOP IMMEDIATELY” and must be taught to react accordingly. Likewise, pilots receiving an ATS clearance to take-off or cross a runway, and seeing the red-light array, must STOP and advise ATS that they aborted/stopped because of the red lights. Again, the criticality of the timeline involved is so tight that there is no room for misinterpretation of the signal. It is of utmost importance that the visual signal be consistent around the world.
- 21.2.2 It must also be stressed that the extinguishing of the red lights does not, in itself, indicate a clearance to proceed. That clearance is still required from air traffic control. The absence of red warning lights only means that potential conflicts have not been detected.
- 21.2.3 In the event that a system becomes unserviceable, one of two things will occur. If the system fails in the extinguished condition, then no procedural changes need to be accomplished. The only thing that will happen is the loss of the automatic, independent warning system. Both ATS operations and flight crew procedures (in response to ATS clearances) will remain unchanged.

21.2.4 Procedures should be developed to address the circumstance where the system fails in the illuminated condition. It will be up to the ATS and/or aerodrome operator to establish those procedures depending on their own circumstances. It must be remembered that flight crews are instructed to “STOP” at all red lights. If the affected portion of the system, or the entire system, is shut off the situation is reverted to the extinguished scenario described in 21.2.3.

### **21.3 Aerodromes**

21.3.1 An ARIWS does not have to be provided at all aerodromes. An aerodrome considering the installation of such a system may wish to assess its needs individually, depending on traffic levels, aerodrome geometry, ground taxi patterns, etc. Local user groups such as the Local Runway Safety Team (LRST) can be of assistance in this process. Also, not every runway or taxiway needs to be equipped with the lighting array(s), and not every installation requires a comprehensive ground surveillance system to feed information to the conflict detection computer.

21.3.2 Although there may be local specific requirements, some basic system requirements are applicable to all ARIWS:

- (a) the control system and energy power supply of the system must be independent from any other system in use at the aerodrome, especially the other parts of the lighting system;
- (b) the system must operate independently from ATS communications;
- (c) the system must provide a globally accepted visual signal that is consistent and instantly understood by crews; and
- (d) local procedures should be developed in the case of malfunction or failure of a portion of, or the entire system. (Eighth Schedule to these Regulations).

### **21.4 Air Traffic Services**

21.4.1 The ARIWS is designed to be complementary to normal ATS functions, providing warnings to flight crews and vehicle operators when some conflict has been unintentionally created or missed during normal aerodrome operations. The ARIWS will provide a direct warning when, for example, ground control or tower (local) control has provided a clearance to hold short of a runway but the flight crew or vehicle operator has “missed” the hold short portion of their clearance and tower has issued a take-off or landing clearance to that same runway, and the non-read back by the flight crew or vehicle operator was missed by air traffic control.

21.4.2 In the case where a clearance has been issued and a crew reports a non-compliance due to “red lights”, or aborting because of “red lights”, then it is imperative that the controller assess the situation and provide additional instructions as necessary. It may well be that the system has generated a

false warning or that the potential incursion no longer exists; however, it may also be a valid warning. In any case, additional instructions and/or a new clearance need to be provided. In a case where the system has failed, then procedures will need to be put into place as described in 21.2.3 and 21.2.4. In no case should the illumination of the ARIWS be dismissed without confirmation that, in fact, there is no conflict. It is worth noting that there have been numerous incidents avoided at aerodromes with such systems installed. It is also worth noting that there have been false warnings as well, usually as a result of the calibration of the warning software, but in any case, the potential conflict existence or non-existence must be confirmed.

21.4.3 While many installations may have a visual or audio warning available to ATS personnel, it is in no way intended that ATS personnel be required to actively monitor the system. Such warnings may assist ATS personnel in quickly assessing the conflict in the event of a warning and help them to provide appropriate further instructions, but the ARIWS should not play an active part in the normal functioning of any ATS facility.

21.4.4 Each aerodrome where the system is installed will develop procedures depending upon its unique situation. Again, it must be stressed that under no circumstances should pilots or operators be instructed to “cross the red lights”. As indicated previously, the use of local runway safety teams can greatly assist in this development process.

## **21.5 Promulgation of Information**

21.5.1 Information on the characteristics and status of an ARIWS at an aerodrome are promulgated in the AIP section AD 2.9 in PANS-AIM (Doc 10066), and its status updated as necessary through NOTAM or ATIS in compliance with 2.9.1 of this Regulation.

21.5.2 Aircraft operators are to ensure that flight crews’ documentation include procedures regarding ARIWS and appropriate guidance information, in compliance with Annex 6, Part I.

21.5.3 Aerodromes may provide additional sources of guidance on operations and procedures for their personnel, aircraft operators, ATS and third-party personnel who may have to deal with an ARIWS.

## **22. Taxiway Design Guidance for Minimizing the Potential for Runway Incursions**

**22.1** Good aerodrome design practices can reduce the potential for runway incursions while maintaining operating efficiency and capacity. The following taxiway design guidance may be considered to be part of a runway incursion prevention programme as a means to ensure that runway incursion aspects are addressed during the design phase for new runways and taxiways. Within this focused guidance, the

prime considerations are to limit the number of aircraft or vehicles entering or crossing a runway, provide pilots with enhanced unobstructed views of the entire runway, and correct taxiways identified as hot spots as much as possible. (Eighth Schedule to these regulations)

- 22.2** The center line of an entrance taxiway should be perpendicular to the runway centre line, where possible. This design principle provides pilots with an unobstructed view of the entire runway, in both directions, to confirm that the runway and approach are clear of conflicting traffic before proceeding towards the runway. Where the taxiway angle is such that a clear unobstructed view, in both directions, is not possible, consideration should be given to providing a perpendicular portion of the taxiway immediately adjacent to the runway to allow for a full visual scan by the pilots prior to entering or crossing a runway.
- 22.3** For taxiways intersecting with runways, avoid designing taxiways wider than recommended in this Annex. This design principle offers improved recognition of the location of the runway holding position and the accompanying sign, marking and lighting visual cues.
- 22.4** Existing taxiways wider than prescribed in this Regulation, can be rectified by painting taxi side stripe markings to the recommended width. As far as practicable, it is preferable to redesign such locations properly rather than to repaint such locations.
- 22.5** Multi-taxiway entrances to a runway should be parallel to each other and should be distinctly separated by an unpaved area. This design principle allows each runway holding location an earthen area for the proper placement of accompanying sign, marking and lighting visual cues at each runway holding position. Moreover, the design principle eliminates the needless costs of building unusable pavement and as well as the costs for painting taxiway edge markings to indicate such unusable pavement. In general, excess paved areas at runway holding positions reduce the effectiveness of sign, marking and lighting visual cues.
- 22.6** Build taxiways that cross a runway as a single straight taxiway. Avoid dividing the taxiway into two after crossing the runway. This design principle avoids constructing “Y-shaped” taxiways known to present risk of runway incursions.
- 22.7** If possible, avoid building taxiways that enter at the mid-runway location. This design principle helps to reduce the collision risks at the most hazardous locations (high energy location) because normally departing aircraft have too much energy to stop, but not enough speed to take-off, before colliding with another errant aircraft or vehicle.
- 22.8** Provide clear separation of pavement between a rapid exit taxiway and other non-rapid taxiways entering or crossing a runway. This design principle avoids two taxiways from overlapping each other to create an excessive paved area that would confuse pilots entering a runway.

- 22.9** Avoid the placement of different pavement materials (asphalt and cement concrete) at or near the vicinity of the runway holding position, as far as practicable. This design principle avoids creating visual confusion as to the actual location of the runway holding position.
- 22.10** Many aerodromes have more than one runway, notably paired parallel runways (two runways on one side of the terminal), which creates a difficult problem in that either on arrival or departure an aircraft is required to cross a runway. Under such a configuration, the safety objective here is to avoid or at least keep to a minimum the number of runway crossings. This safety objective may be achieved by constructing a “perimeter taxiway”. A perimeter taxiway is a taxi route that goes around the end of a runway, enabling arrival aircraft (when landings are on outer runway of a pair) to get to the terminal, or departure aircraft (when departures are on outer runway of a pair) to get to the runway, without either crossing a runway or conflicting with a departing or approaching aircraft.
- 22.11** A perimeter taxiway would be designed according to the following criteria:
- (a) Sufficient space is required between the landing threshold and the taxiway centre line where it crosses under the approach path to enable the critical taxiing aircraft to pass under the approach without penetrating any approach surface.
  - (b) The jet blast impact of aircraft taking off should be considered in consultation with aircraft manufacturers; the extent of take-off thrust should be evaluated when determining the location of a perimeter taxiway. Eighth Schedule to these Regulations.
  - (c) The requirement for a runway end safety area, as well as possible interference with landing systems and other navigation aids should also be taken into account. For example, in the case of an ILS, the perimeter taxiway should be located behind the localizer antenna, not between the localizer antenna and the runway, due to the potential for severe ILS disturbance, noting that this is harder to achieve as the distance between the localizer and the runway increases.
  - (d) Human factors issues should also be taken into account. Appropriate measures should be put in place to assist pilots to distinguish between aircraft that are crossing the runway and those that are safely on a perimeter taxiway.

## **23. Aerodrome Mapping Data**

- 23.1** Part IV, Regulation 18(2) and 18(3), relate to the provision of aerodrome mapping data. The aerodrome mapping data features are collected and made available to the aeronautical information services for aerodromes designated by States with consideration of the intended applications. These applications are closely tied to an identified need and operational use where the application of the data would provide a safety benefit or could be used as mitigation of a safety concern.

## **23.2 Applications**

23.2.1 Aerodrome mapping data include aerodrome geographic information that supports applications which improve the user's situational awareness or supplement surface navigation, thereby increasing safety margins and operational efficiency. With appropriate data element accuracy, these data sets support collaborative decision-making, common situational awareness and aerodrome guidance applications. The data sets are intended to be used in the following air navigation applications:

- (a) on-board positioning and route awareness including moving maps with own aircraft position, surface guidance and navigation;
- (b) traffic awareness including surveillance and runway incursion detection and alerting (such as, respectively, in A-SMGCS levels 1 and 2);
- (c) ground positioning and route awareness including situational displays with aircraft and vehicles position and taxi route, surface guidance and navigation (Such as A-SMGCS levels 3 and 4);
- (d) facilitation of aerodrome-related aeronautical information, including NOTAMs;
- (e) resource and aerodrome facility management; and
- (f) aeronautical chart production.

23.2.2 The data may also be used in other applications such as training/flight simulators and on-board or ground enhanced vision systems (EVS), synthetic vision systems (SVS) and combined vision systems (CVS). Annex 14 — Aerodromes Volume I 8/11/18 ATT A-36.

## **23.3 Determination of Aerodromes to Be Considered for Collection of Aerodrome Mapping Data Features**

In order to determine which aerodromes may make use of applications requiring the collection of aerodrome mapping data features, the following aerodrome characteristics may be considered: – safety risks at the aerodrome; – visibility conditions; – aerodrome layout; and – traffic density.

Note: Further guidance on aerodrome mapping data can be found in the Airport Services Manual, Part 8 — Airport Operational Service (Doc 9137).

# NINTH SCHEDULE

## Regulation 61

### OBSTACLE LIMITATION SURFACES

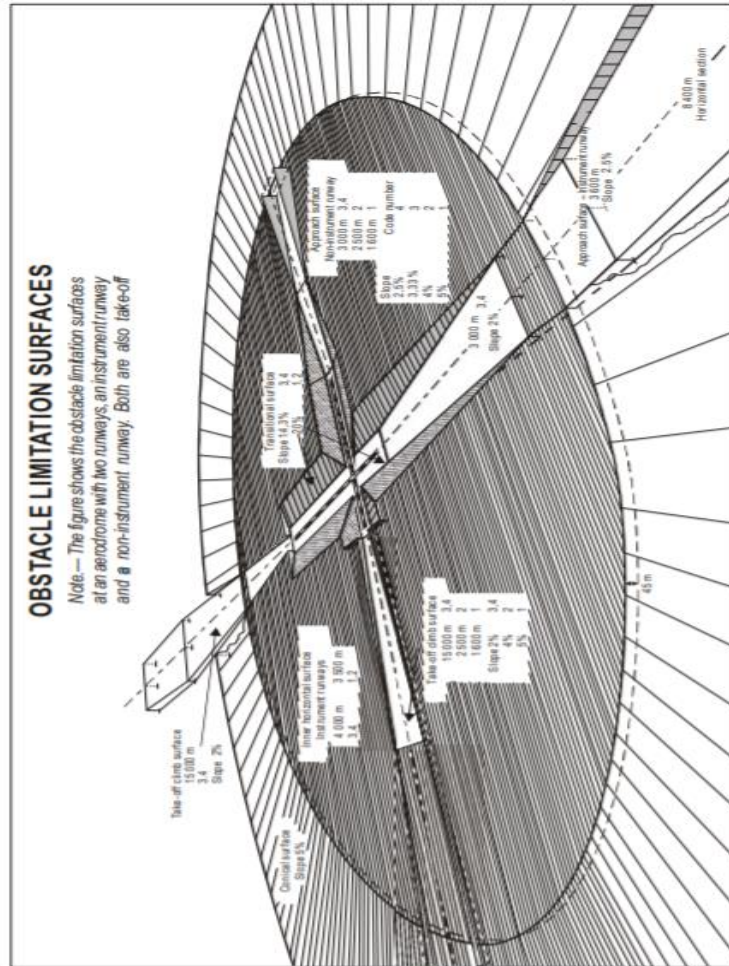

Figure B-1

Table1: Response on gender (n= 20)

<b>Gender</b>	Frequency	Percentage (%)
Male	10	50.0
FEMALE	10	50.0
Total	20	100.0

Source: Primary data (2024)

Issued under my hand in Juba on this <sup>1h</sup> 12 ..... day of the month of Feb. .... in Year 2026.

12 02  
2026



Hon Rizik Zakaria Hassan  
Minister of Transport  
Republic of South Sudan - Juba